

Professional in development and manufacture | SINCE 1988

Pressure Sensor | Magnetic Sensor | Connector



KITA SENSOR TECH. CO., LTD. established in Oct. 1988, located in New Taipei Industrial Park, Wugu Dist., New Taipei City, Taiwan. Producing Hydraulic / Pneumatic magnetic-sensor and pressure-sensor are our major business.

With the efforts in R&D for more than decades in the field of automation, our above-mentioned products have been not only widely accepted by the Taiwan users but also exported to the overseas markets since 1996. Moreover, KITA SENSOR earned ISO 9001 international quality assessment certificate in April 1998 for the quality assurance. **QUALITY GUARANTEED.**

As of Dec. 2000, our products have been distributed accompanied with CE inspection approval to the developed countries : U.S., Europe, Japan, etc. KITA SENSOR persist in satisfying the customer's needs and pursuing the superiority in product's quality through innovation.



■ TAIWAN / Yilan Factory



■ CHINA / Chang Shu Factory



■ TAIWAN / Headquarter



## Introduction to Branch Companies

📍 Overseas Offices

● Overseas Markets





## P.06

### Pressure Sensor

Caution .....	P.07
Application .....	P.08
Industrial Internet of Things Applications	P.10
KP10 Series .....	P.12
KP101 / 102 Series .....	P.18
KP1 Series .....	P.20
KP30 Series .....	P.24
KP43 Series .....	P.28
KP45 Series .....	P.32
KP45S Series .....	P.36
KP47 Series .....	P.40
KP50E Series .....	P.44
KP52 Series .....	P.48
KP60 Series .....	P.52
KP61 Series .....	P.54
KP70 Series .....	P.56
KP75 Series .....	P.60
KP90 Series .....	P.64
KP400 Series .....	P.68
KP610 Series .....	P.72
KP800 Series .....	P.76
KGS Series .....	P.80



## P.84

### Magnetic Sensor

Ordering Information & Connection Method	P.85
Cylinder / Magnetic Sensor Cross Index	P.86
Magnetic Sensor Operating & Installing	P.88
Caution .....	P.89
Hot Sale .....	P.90



KT-05 Series .....	P.92	KT-53 Series .....	P.113
KT-06 Series .....	P.93	KT-58 Series .....	P.114
KT-07 Series .....	P.94	KT-59 Series .....	P.115
KT-09 Series .....	P.95	KT-65 Series .....	P.116
KT-11 Series .....	P.96	KT-65-EX Series .....	P.117
KT-13 Series .....	P.97	KT-65-UL Series .....	P.118
KT-15 Series .....	P.98	KT-71 Series .....	P.119
KT-16 Series .....	P.99	KT-75 Series .....	P.120
KT-20 Series .....	P.100	KT-77 Series .....	P.121
KT-21 Series .....	P.101	KT-1000D Weld-field Immune Sensor	P.122
KT-31 Series .....	P.102	KT-1001D Weld-field Immune Sensor	P.124
KT-32 Series .....	P.103	Bracket .....	P.125
KT-32-EX Series .....	P.104	Clamp .....	P.129
KT-33 Series .....	P.105	Magnet .....	P.135
KT-36 Series .....	P.106		
KT-37 Series .....	P.107		
KT-38 Series .....	P.108		
KT-40 Series .....	P.109		
KT-47 Series .....	P.110		
KT-48 Series .....	P.111		
KT-50 Series .....	P.112		



## P.136

### Circular Connector

M8 □ R Series .....	P.137
KM8 □ R Series .....	P.138
M8 □ QD Series .....	P.139
M8 □ SW Series .....	P.140
M12 □ R Series .....	P.141
M12 □ QD Series .....	P.142



# Pressure Sensor

**KP10 Series**



P.12

**KP101 / 102 Series**



P.18

**KP1 Series**



P.20

**KP30 Series**



P.24

**KP43 Series**



P.28

**KP45 Series**



P.32

**KP47 Series**



P.40

**KP52 Series**



P.48

**KP60 Series**

Patented  
Battery Meter



P.52

**KP61 Series**



P.54

**KP70 Series**

RS485



P.56

**KP75 Series**

RS485



P.60

**KP90 Series**



P.64

**KP400 Series**



P.68

**KP610 Series**

Differential Pressure Sensor



P.72

**KP800 Series**

Differential Pressure Sensor



P.76

**KGS Series**

Gap Sensor



P.80

# Caution

**1** When using a 2-wire type pressure sensor ( KP101 / 102 & KP10A / 10B ), please make sure it is connected to a DC power source and a proper resistance load. Otherwise excessive current will damage the sensor permanently.

Always connect the brown wire to the positive ( + ), blue wire to the negative ( - ).

Permanent damages to the pressure sensor will occur if the connections are reversed.

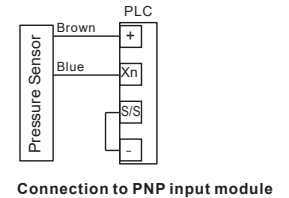
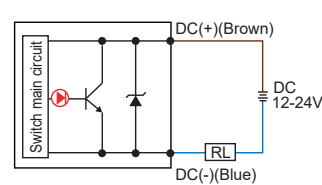
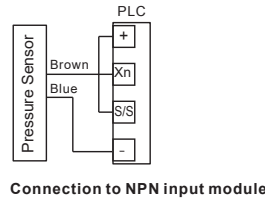
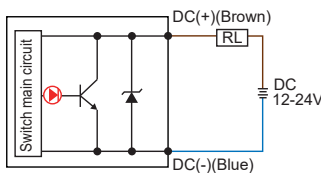

**2** To improve stability of the pressure sensor and the whole circuit in general, it is recommended to properly ground the DC power source.

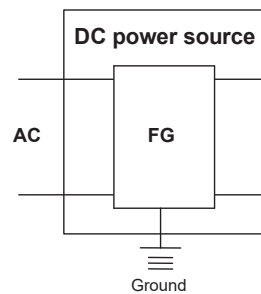

**3** When using with inductive load ( such as relay or solenoid ), please install a flyback diode across the load to remove surge and polarity must be observed or damages to pressure sensor may occur.

### 2 wire switch type

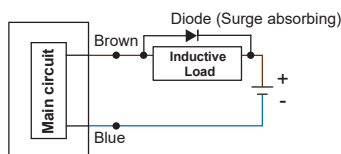

### NPN type

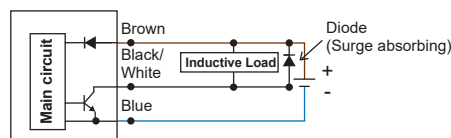

### PNP type

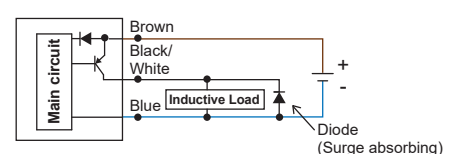

**4** Before sensor installation or removal, please make sure the power is OFF and pressure in pipe has been released, released to avoid personal injuries, sensor damage or other losses.

**5** Please separate the power supply of a variable frequency driver or a motor driver from the pressure power supply to avoid noise affect the pressure sensor normal operation.

**6** Do not use corrosive gases or liquids as pressure media.

# Application

## Detection of Line Pressure

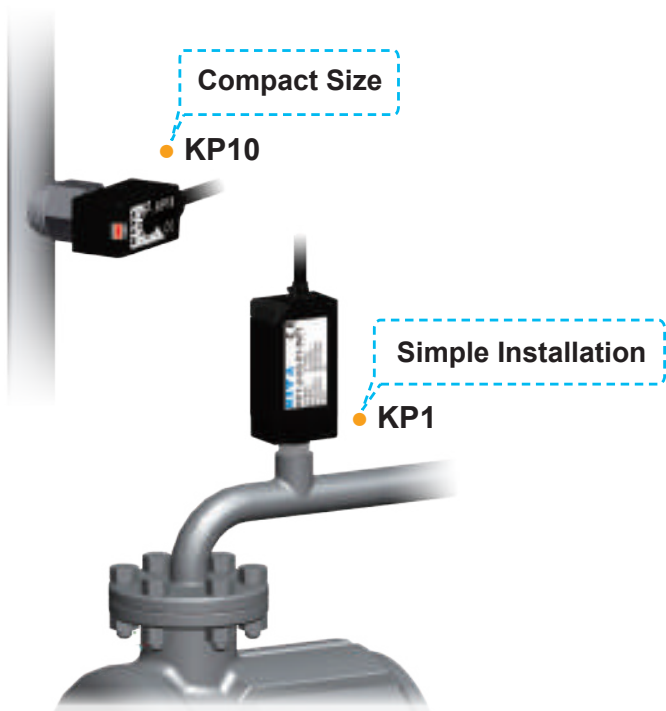

## Pressure Display of Line Pressure

- Digital display, easy readout
- Replace traditional pressure gauge

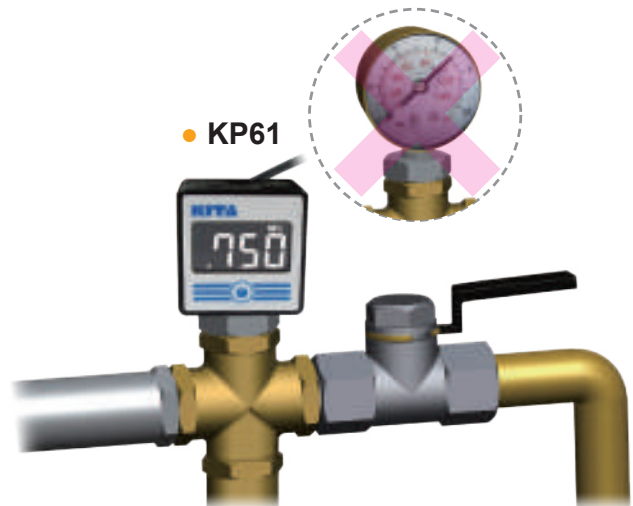

## Pressure Display and Control of Pneumatic Equipment

- LCD display
- 2 outputs and 1 analog output (1 ~ 5 V or 4 ~ 20 mA)



## Pressure Display and Control of Pressure in Reservoir Tank

- Programmable pressure unit : 6 types
- IP65 enclosure



## Pressure Display and Control of Press Machine

- Upright pressure sensor save installation space
- 2 outputs and 1 analog output ( 1 ~ 5 V )

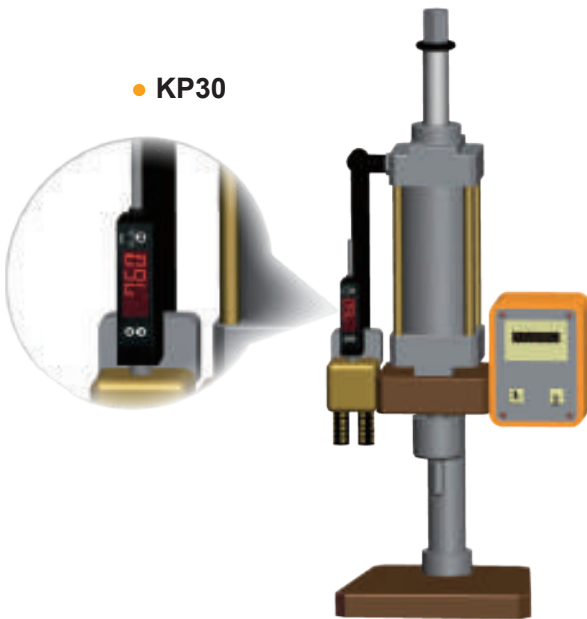

## Leakage Test

- 3-color digital display, easy readout



## Operation of Suction Pads

- 3-color digital LCD display
- 7 response time for selection
- 2 outputs and 1 analog output ( 1 ~ 5 V or 4 ~ 20 mA )

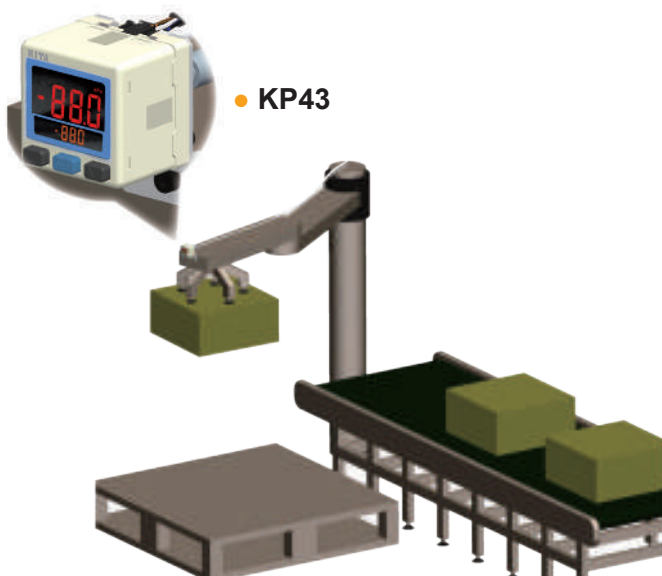

## Pressure Display of F.R.L Unit

- Battery type without extra power supply
- 6 pressure units for selection
- IP65 enclosure

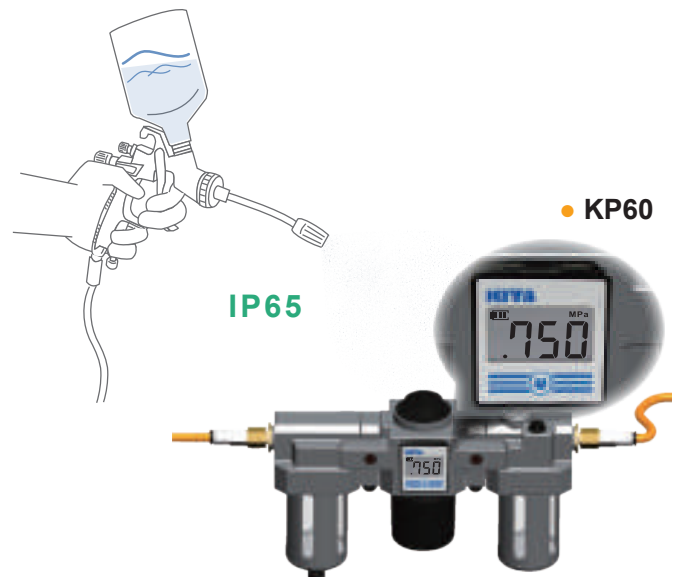

# Industrial Internet of Things Applications

RS485 MODBUS CONTROL

## Remote Control

A large amount of sensor needs to be set on machine at production line; However, sensor's parameter must be set individually. Is it efficient enough?

► Smart sensors KP70 and KP75 series brings these benefits and makes IIOT in practice.

KP70 refer to P.56

KP75 refer to P.60

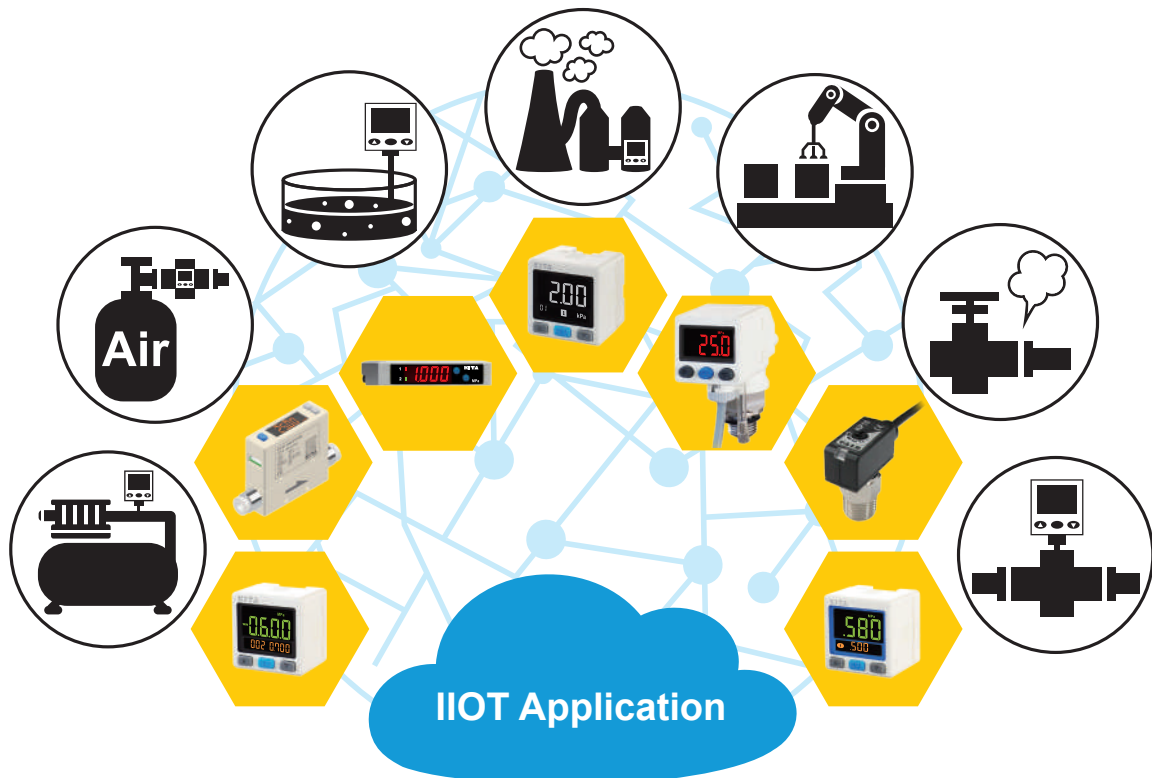

## Application

In warehouse moving system, utilizing data-analysis and remote-control to elongate the life span of suction pad that prevent carton fall from robot and damage-cause. Furthermore, all setting can be done on the remote site with one click.

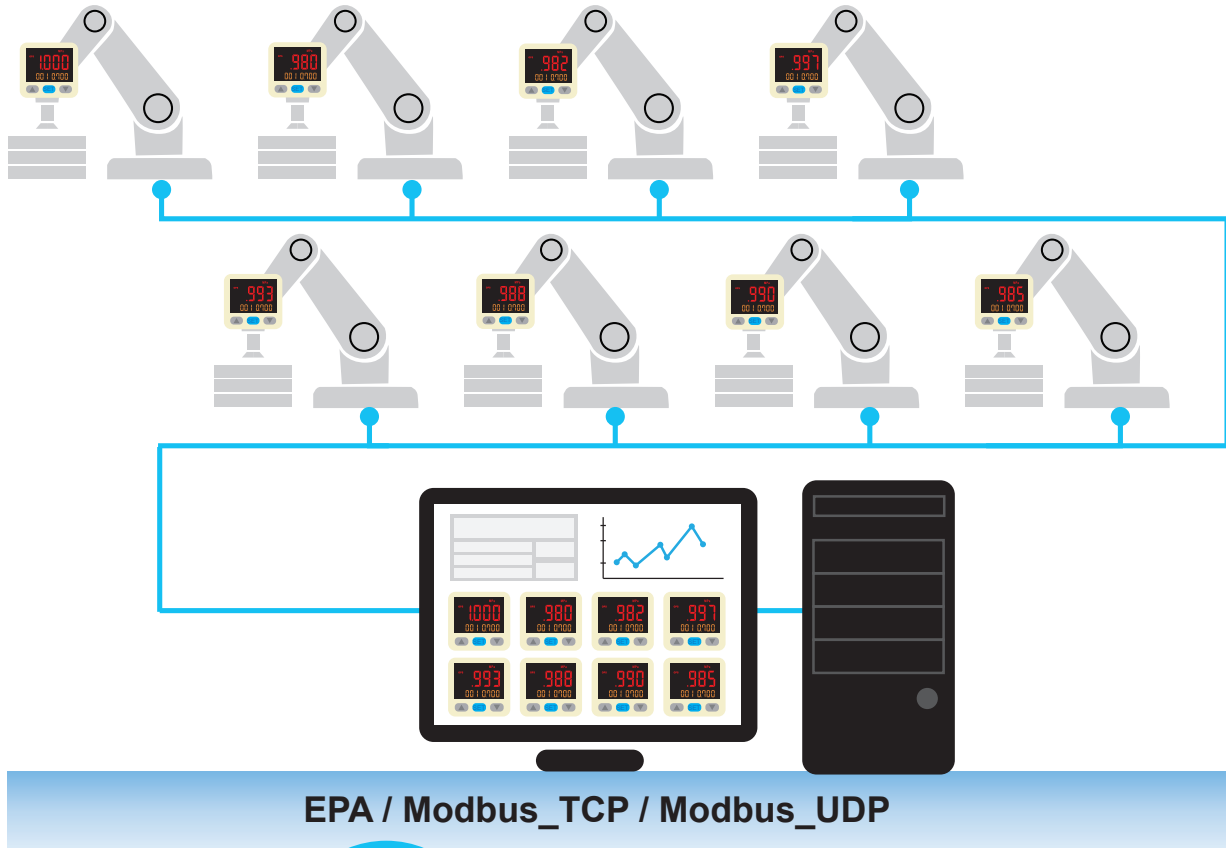

### Prevent Damage

Early warning to prevent goods fall from robot or machine halt before suction cup break.

### Remote Control

Pressure sensor does not need to be set individually, reduce fabricator setting time dramatically.

### Maintain in Time

Monitoring in time and data analysis, leakage, energy waste will be nowhere to hide.

# KP10 SERIES

Compact Pressure Sensor  
- Switch Output

## Features

- Simple installation, plug-in port or thread-in fitting
- Set pressure range :
  - 3-wire type : Vacuum ( 0 ~ -101.3 kPa )
  - Positive ( 0 ~ 0.6 MPa )
- 2-wire type : Normally Open /  
Normally Close ( - 0.1 ~ 0.6 MPa )

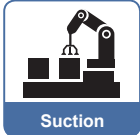

Suction

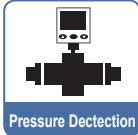

Pressure Detection

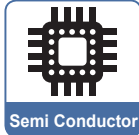

Semi Conductor



## Features Highlight

### 1 Simple Installation

- Plug-in port for push-to-connect fittings

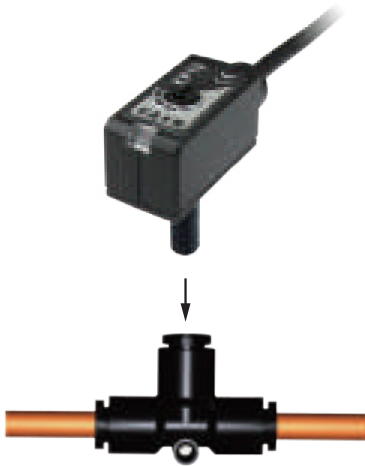

### 2 Compact Size

- Extremely compact size 26(L) × 10(W) × 10.4(H) mm to fit the most confined areas

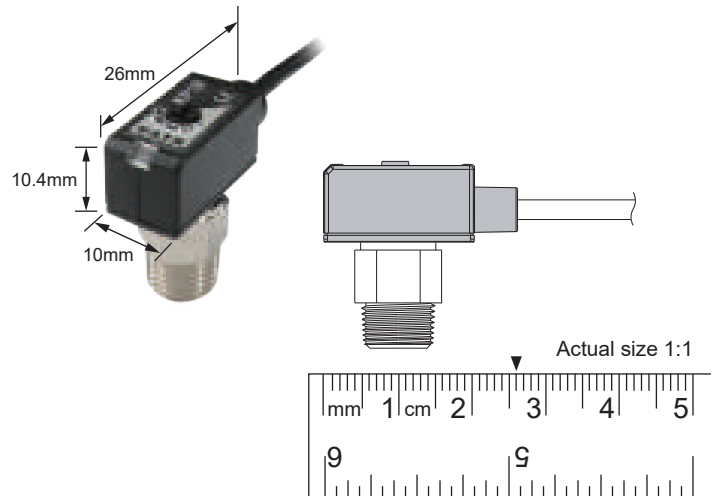

### 3 Space-Saving

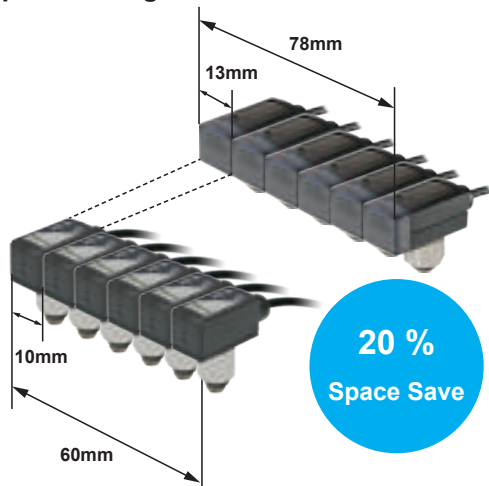

### 4 Sensor Installed Close to Pad



## Specifications

MODEL	KP10A	KP10B	KP10V-02/04	KP10P-02/04
Set Pressure Range	- 0.1 ~ 0.6 MPa		0 ~ - 101.3 kPa	0 ~ 0.6 MPa
Withstand Pressure	1.5 MPa		0.6 MPa	1.5 MPa
Fluid	Air, Non-corrosive / Non-flammable gas			
Load Voltage	12 to 24 V DC $\pm$ 10 %, Ripple ( P-P ) $\leq$ 10 %		10.8 to 30 V DC ( include ripple voltage )	
Load Current	5 ~ 40 mA		$\leq$ 80 mA	
Leak Current	$\leq$ 1 mA		-	
Internal Voltage Drop	$\leq$ 5 V		NPN $\leq$ 0.8 V, PNP $\leq$ 0.8 V	
Current Consumption	-		$\leq$ 10 mA	
Switch Output	Present Press. $\geq$ Set Press. : ON	Present Press. $\geq$ Set Press. : OFF	NPN or PNP	
Output Short Circuit Protection	No		Yes	
Setting Method	Adjusting by VR			
Repeatability	$\pm$ 1 % F.S.			
Response Time	Approx. 1 ms			
Hysteresis	$\leq$ 4 % F.S.		$\leq$ 3 % F.S.	
Switch on Indicator	Indicator Red : ON			
Enclosure	IP40			
Temperature Characteristic	$\pm$ 3 % F.S. of detected pressure ( 25 °C ) at temp. Range of 0 ~ 50 °C			
Ambient Temp. Range	Operation : 0 ~ 60 °C ( 32 ~ 140 °F ), Storage : -20 ~ 70 °C ( -4 ~ 158 °F ) ( No condensation or freezing )			
Ambient Humidity Range	Operation / Storage : 35 ~ 85 % RH ( No condensation )			
Vibration	Total amplitude 1.5 mm or 10 G, 10 Hz - 55 Hz - 10 Hz scan for 1 minute, two hours each direction of X, Y and Z			
Shock	980 m/s <sup>2</sup> ( 100 G ), 3 times each in direction of X, Y and Z			
Piping Size	R4 : $\varnothing$ 4 mm ; R6 : $\varnothing$ 6 mm ; F1 : R1/8", M5 ; F2 : NPT1/8", M5 ; F3 : G1/8" ( BSPP ), M5 ; M5 : M5 * 0.8			
Lead Wire	Oil-resistance cable, 2 / 3 wires ( 0.18 mm <sup>2</sup> ), $\varnothing$ 2.6			
Weight ( with 3 meter lead wire )	Approx. 50 g			

## Circuit Wiring Diagram

### KP10A & KP10B

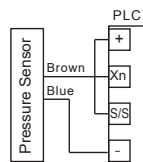
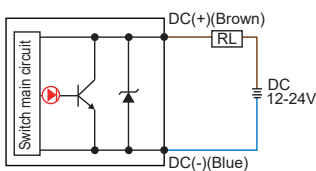

Connection to NPN input module

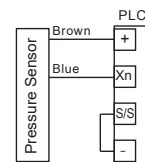
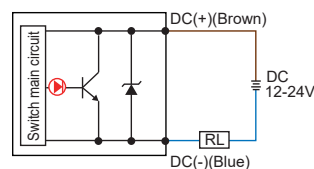

Connection to PNP input module

### KP10□ - 02 - □ - □

#### NPN Output

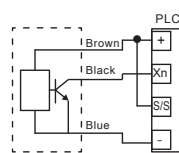
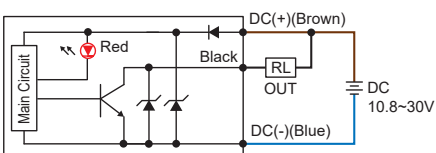

### KP10□ - 04 - □ - □

#### PNP Output

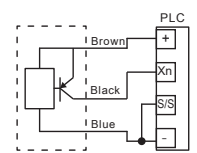
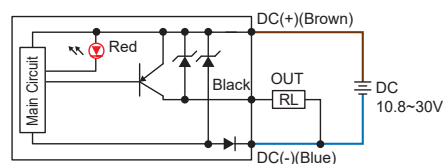

# KP10 SERIES

## Compact Pressure Sensor - Switch Output

### Output Type

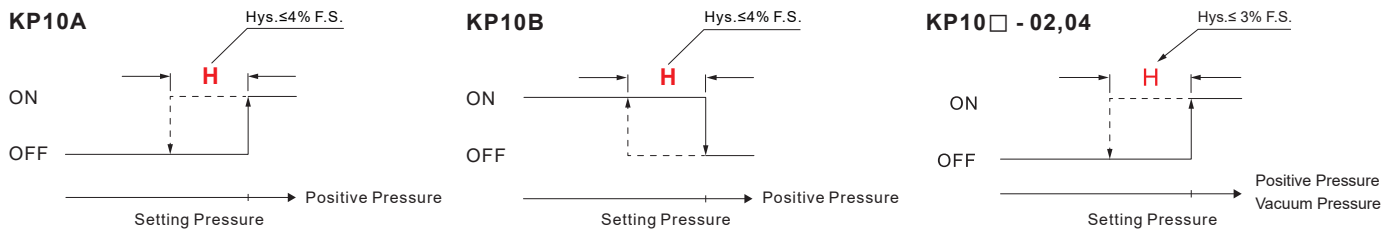

### Ordering Information

**K P 1 0 A - R 4 -**

#### Switch Specifications

- A : Switch turns ON when the pressure is larger than setting pressure. ( Normally Open )
- B : Switch turns OFF when the pressure is larger than setting pressure. ( Normally Close )

**K P 1 0 V - 0 2 - R 4 -**

#### Pressure Range

- V : Vacuum ( 0 ~ -101.3 kPa )
- P : Positive ( 0 ~ 0.6 MPa )

#### Output Specification

- 02 : NPN output
- 04 : PNP output

#### Cable Length / Connector

- Blank : With 3 meter cable
- C : With M8, 3Pin male connector

Pressure Port	R4	R6	F1 / F2 / F3	M5
Appearance				
Port size	R4 : Ø4 mm	R6 : Ø6 mm	F1 : R1/8", M5 F2 : NPT1/8", M5 F3 : G1/8" ( BSPP ), M5	M5 : M5 * 0.8

### How to Set Pressure

- Use the pressure setting trimmer to set "ON" pressure. Rotate clockwise to increase pressure setpoint. Rotate counter-clockwise to decrease pressure setpoint.
- Use appropriate size screwdriver for the setting trimmers. Gently turn the screwdriver to make adjustments. To prevent damage to the pressure setting trimmer, DO NOT force the trimmer when it comes to a stop.

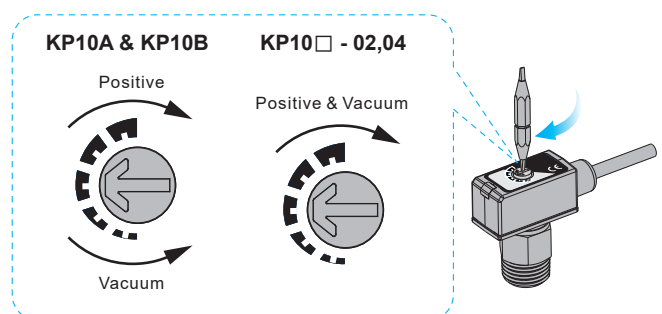

## Installation Precautions

- When mounting, always use the wrench on the metallic area near the pressure port. Never apply a wrench to the plastic body, it will damage the sensor.
- Over tightening may cause damages to the port thread, mounting bracket and pressure sensor. Under tightening may result loosen or leakage.
- Apply pressure and power after installation and make necessary adjustments and inspect any possible signs of leakage to ensure proper installation.

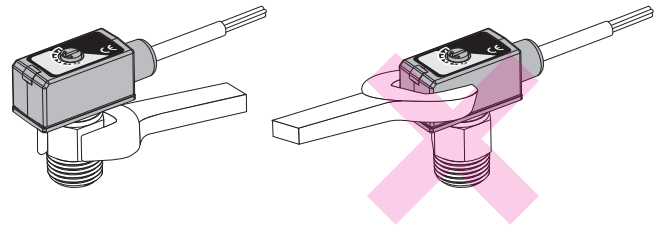

## Dimensions

KP10□ - 02, 04 - □ - C

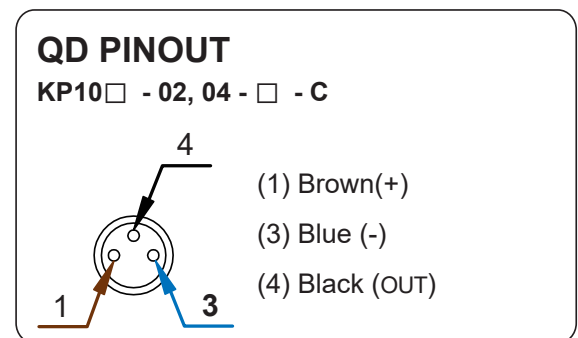
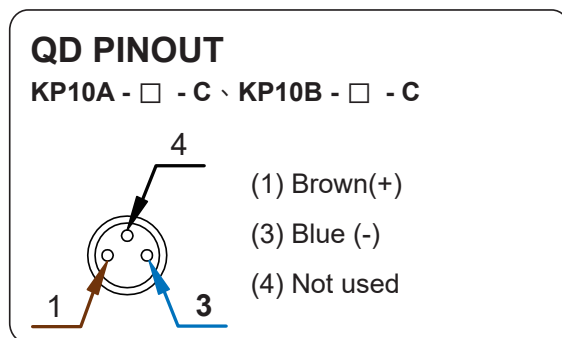
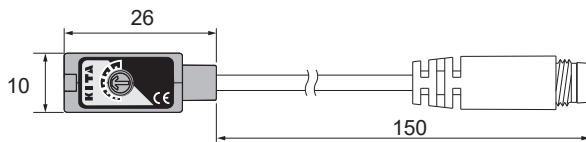

KP10□ - 02, 04 - F1, F2, F3

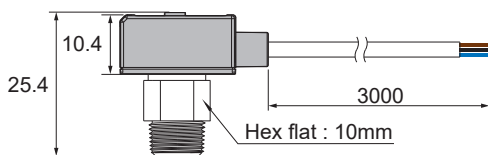

KP10□ - 02, 04 - R6

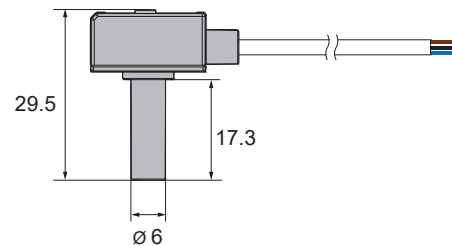

KP10□ - 02, 04 - M5

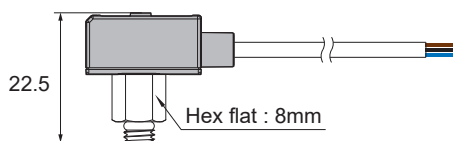

KP10□ - 02, 04 - R4

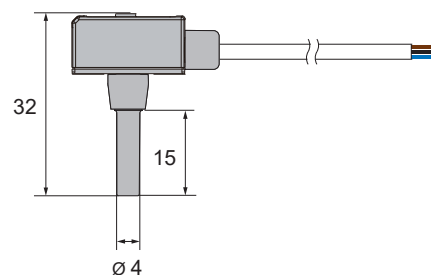

Unit : mm

# KP10 SERIES

Compact Pressure Sensor  
- Analog Output

## Features

- Simple installation, plug-in port or thread-in fitting
- Compact size : 26 × 10 × 10.4 mm
- Rated pressure range :
  - Compound ( -100 ~ 100 kPa )
  - Compound ( -101 ~ 500 kPa )
  - Low ( 0 ~ 100 kPa )
  - Vacuum ( 0 ~ -101.3 kPa )
  - Positive ( 0 ~ 1.0 MPa )
  - Micro pressure S1 ( 0 ~ 10 kPa )
  - Micro pressure S2 ( 0 ~ 5 kPa )

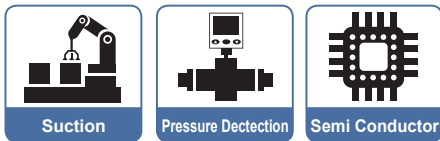

## Specifications

MODEL	KP10S1	KP10S2	KP10C-01	KP10L-01	KP10V-01	KP10R-01	KP10P-01
Rated Pressure Range	0 ~ 10 kPa	0 ~ 5 kPa	-100 ~ 100 kPa	0 ~ 100 kPa	0 ~ -101.3 kPa	-101 ~ 500 kPa	0 ~ 1.0 MPa
Withstand Pressure	20 kPa		0.2 MPa			1.5 MPa	
Fluid	Filtered air, Non-corrosive / Non-flammable gas						
Power Supply Voltage	12 to 24 V DC ( 5 % ripple voltage )						
Current Consumption	≤ 15 mA		≤ 10 mA				
Analog Output	1 ~ 5 V ± 1 % F. S. / Linearity ± 0.5 % F. S.		1 ~ 5 V ± 1 % F. S. / Linearity ± 0.5 % F. S.				
Enclosure	IP40						
Temperature Characteristic	± 3 % F.S. ( Range of 0 ~ 50 °C )		± 2 % F.S. ( Range of 0 ~ 50 °C )				
Ambient Temp. Range	Operation : 0 ~ 50 °C ( 32 ~ 122 °F ), Storage : -20 ~ 70 °C ( -4 ~ 158 °F ) ( No condensation or freezing )						
Ambient Humidity Range	Operation / Storage : 35 ~ 85% RH ( No condensation)						
Vibration	Total amplitude 1.5 mm or 10 G, 10 Hz - 55 Hz - 10 Hz scan for 1 minute, two hours each direction of X, Y and Z						
Shock	980 m/s <sup>2</sup> ( 100 G ), 3 times each in direction of X, Y and Z						
Piping Size	R4 : ø4 mm ; R6 : ø6 mm ; F1 : R1/8", M5 ; F2 : NPT1/8", M5 ; F3 : G1/8" ( BSPP ) , M5 ; M5 : M5 * 0.8						
Lead Wire	Oil-resistance cable, 3 wires ( 0.18 mm <sup>2</sup> ), Ø 2.6 mm						
Weight ( with 3 meter lead wire )	Approx. 50 g						

## Circuit Wiring Diagrams

KP10S□ - 01 - □ - □  
Analog Output ( 1 ~ 5 V )

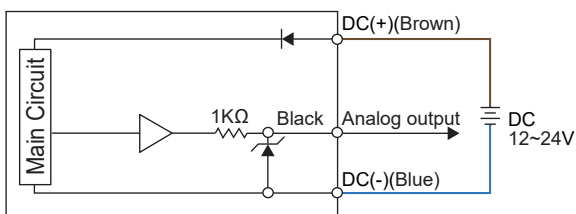

KP10□ - 01 - □ - □  
Analog Output ( 1 ~ 5 V )

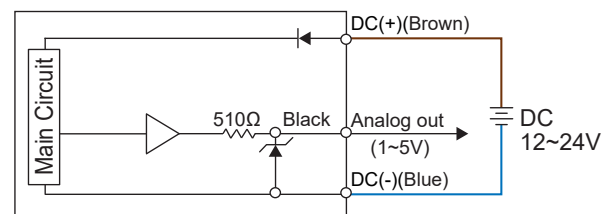

## Output Type

KP10□ - 01 - □ - □

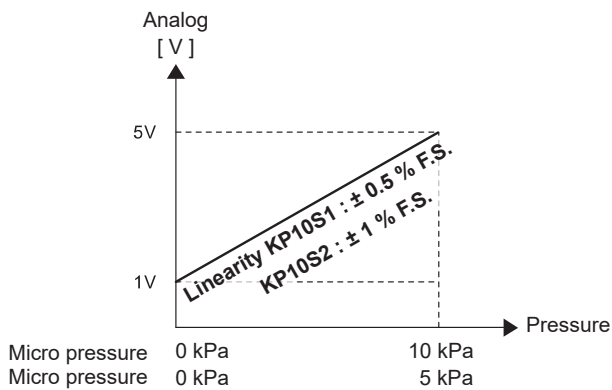

KP10□ - 01 - □ - □

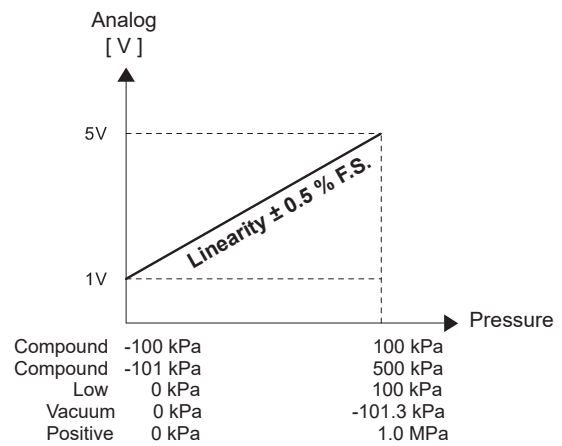

## Ordering Information

**K P 1 0 V - 0 1 - R 4 -**

### Pressure Range

C : Compound ( -100 ~ 100 kPa ) P : Positive ( 0 ~ 1.0 MPa )  
R : Compound ( -101 ~ 500 kPa ) S1 : Micro pressure ( 0 ~ 10 kPa )  
L : Low ( 0 ~ 100 kPa ) S2 : Micro pressure ( 0 ~ 5 kPa )  
V : Vacuum ( 0 ~ -101.3 kPa )

### Output Specification

01 : Analog output  
( 1 ~ 5 V )

### Cable Length / Connector

Blank : With 3 meter cable  
C : With M8 3Pin male connector

### Pressure Port

R4 : Ø4 mm      F2 : NPT1/8", M5  
R6 : Ø6 mm      F3 : G1/8" ( BSPP ), M5  
F1 : R1/8", M5      M5 : M5 \* 0.8

## Dimensions

KP10□ - 01 - □ - C

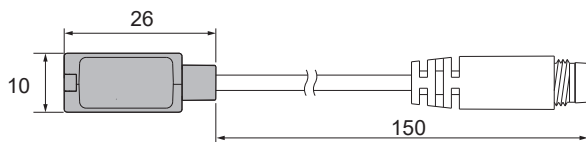

KP10□ - 01 - R4

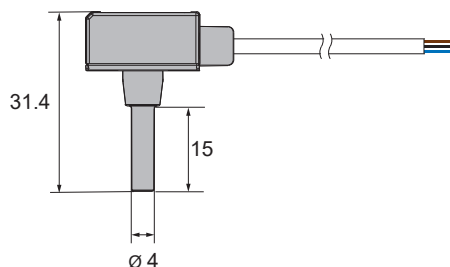

KP10□ - 01 - R6

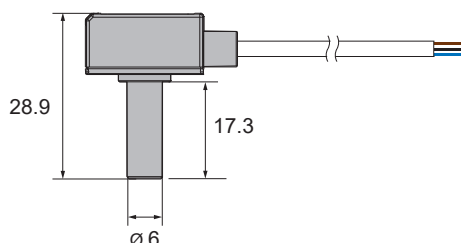

### QD PINOUT

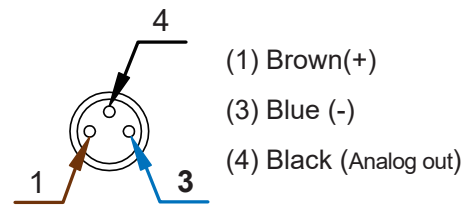

KP10□ - 01 - F1, F2, F3

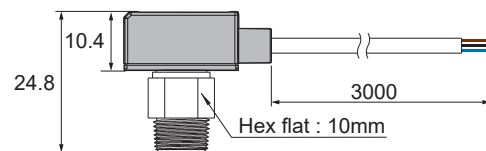

KP10□ - 01 - M5

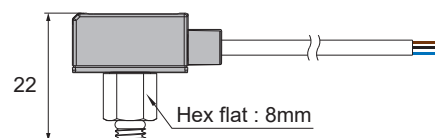

Unit : mm

# KP101 KP102

## SERIES

# Compact Pressure Sensor

### Features

- Simple installation, plug-in port or thread-in fitting
- Set pressure range : -0.1 ~ 0.4 MPa
- Normally Open / Normally Close

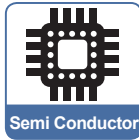
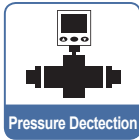
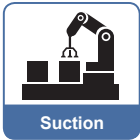

### Features Highlight

#### 1 Simple Installation

- Plug-in port for push-to-connect fittings

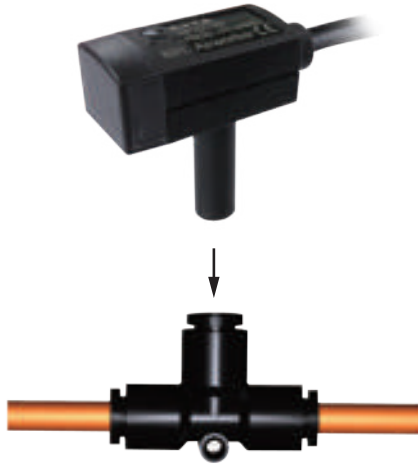

#### 2 Compact Size

- Extremely compact size 30(L) × 13(W) × 11.5(H)mm to fit the most confined areas

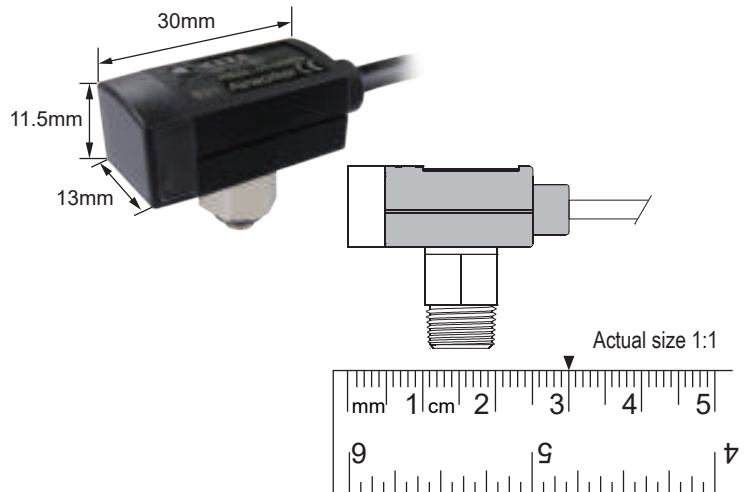

### Specifications

MODEL	KP101	KP102
Set Pressure Range	- 0.1 ~ 0.4 MPa	
Withstand Pressure	1 MPa	
Fluid	Filtered air, Non-corrosive / Non-flammable gas	
Load Voltage	12 to 24 V DC ± 10 %, Ripple ( P-P ) ≤ 10 %	
Load Current	5 ~ 40 mA	
Leak Current	≤ 1 mA	
Internal Voltage Drop	≤ 5 V	
Switch Output	Present Press. ≥ Set Press. : ON	Present Press. ≥ Set Press. : OFF
Repeatability	± 1 % F.S.	
Response Time	Approx. 1 ms	
Hysteresis	≤ 4 % F.S.	
Switch on Indicator	Indicator Red : ON	
Enclosure	IP40	
Temperature Characteristic	± 3 % F.S. of detected pressure ( 25 °C ) at temp. Range of 0 ~ 50 °C	
Ambient Temp. Range	Operation : 0 ~ 60 °C ( No condensation or freezing )	
Piping Size	R6 : ø6 mm ; F1 : R1/8" , M5 ; F2 : NPT1/8" , M5 ; F3 : G1/8" ( BSPP ), M5 ; M5 : M5 * 0.8	
Lead Wire	Oil-resistance cable, 2 wires ( 0.18 mm <sup>2</sup> ), Ø 2.6 mm	
Weight ( with 2 meter lead wire )	Approx. 38 g	

## Circuit Wiring Diagram

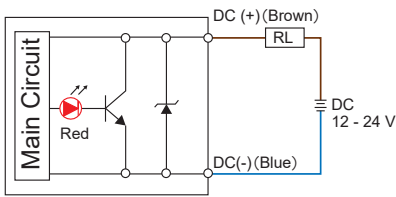

## Output Type

KP101

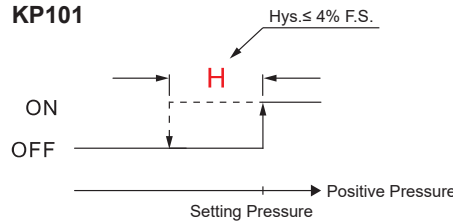

KP102

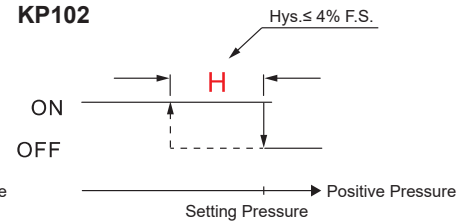

## Ordering Information

**K P 1 0 1 - F 1 - [ ]**

### Sensor Specification

- 101 : Switch turns ON when the pressure is larger than setting pressure.
- 102 : Switch turns OFF when the pressure is larger than setting pressure.

### Pressure Port

- R6 : Ø6 mm
- F3 : G1/8" ( BSPP ), M5
- F1 : R1/8", M5
- M5 : M5 \* 0.8
- F2 : NPT1/8", M5

### Cable Length / Connector

- Blank : With 2 meter cable
- C : With M8 3Pin male connector

## How to Set Pressure

- Use the pressure setting trimmer to set "ON" pressure. Rotate clockwise to increase pressure setpoint ( or to decrease vacuum setpoint ). Rotate counter-clockwise to decrease pressure setpoint ( or to increase vacuum setpoint ).
- Use appropriate size screwdriver for the setting trimmers. Gently turn the screwdriver to make adjustments. To prevent damage to the pressure setting trimmer, DO NOT force the trimmer when it comes to a stop.

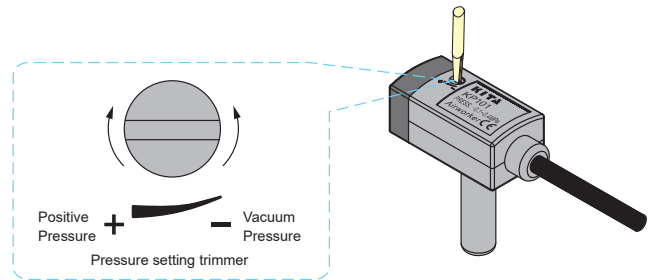

## Installation Precautions

- When mounting, always use the wrench on the metallic area near the pressure port. Never apply a wrench to the plastic body, it will damage the sensor.
- Over tightening may cause damages to the port thread, mounting bracket and pressure sensor. Under tightening may result loosen or leakage.
- Apply pressure and power after installation and make necessary adjustments and inspect any possible signs of leakage to ensure proper installation.

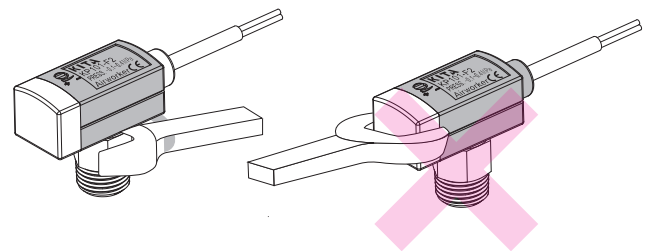

## Dimensions

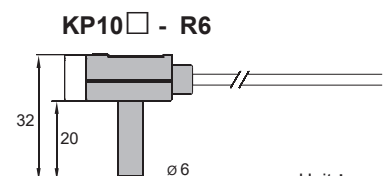
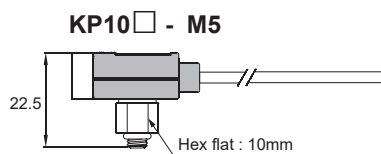
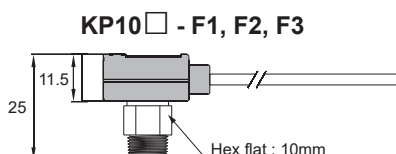
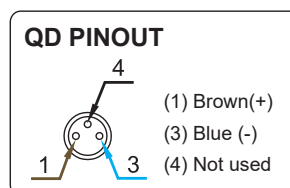
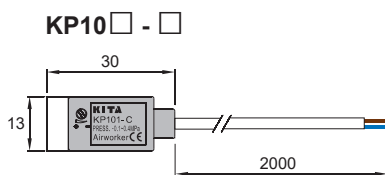

Unit : mm

## Features

- 1 output ( hysteresis adjustable )
- 2 outputs
- Easy installation
- Response time: less than 5 ms

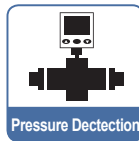
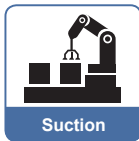

## Features Highlight

### 1 Hysteresis Adjustable

- Output hysteresis (H) is user adjustable

KP1- □ - 01, 02

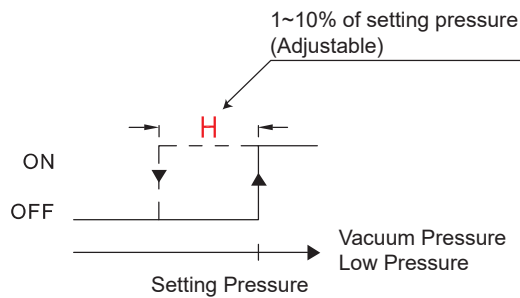

KP1 - □ - 03

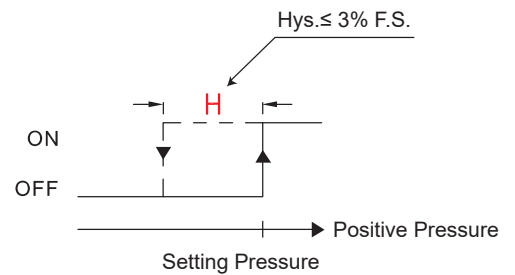

## Installation Precautions

- When mounting, always use the wrench on the metallic area near the pressure port. Never apply a wrench to the plastic body, it will damage the sensor.
- Over tightening may cause damages to the port thread, mounting bracket and pressure sensor. Under tightening may result loosen or leakage.
- Apply pressure and power after installation and make necessary adjustments and inspect any possible signs of leakage to ensure proper installation.

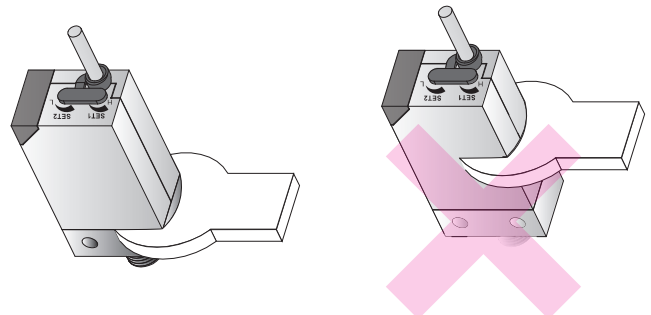

## Specifications

MODEL	KP1-1 (Vacuum)	KP1-2 (Low)	KP1-3 (Positive)
<b>Set Pressure Range</b>	-101 ~ 0 kPa	0 ~ 100 kPa	0 ~ 1 MPa
<b>Withstand Pressure</b>	300 kPa		1.5 MPa
<b>Fluid</b>	Filtered air, Non-corrosive / Non-flammable gas		
<b>Power Supply Voltage</b>	12 to 24 V DC $\pm 10\%$ , Ripple ( P-P ) 10 % or less		
<b>Response Time</b>	5 ms or less		
<b>Repeatability</b>	$\pm 1\%$ F.S.		
<b>Current Consumption</b>	1 NPN or 1 PNP output : 21 mA max. ; 2 NPN output : 35 mA max.		
<b>Environment</b>	<b>Enclosure</b>	IP40	
	<b>Ambient Temp. Range</b>	Operation : 0 ~ 50 °C, storage : -20 ~ 60 °C ( No condensation or freezing )	
	<b>Ambient Humidity Range</b>	Operation / Storage : 35 ~ 85 % RH ( No condensation )	
	<b>Withstand Voltage</b>	1000 V AC in 1-min ( between case and lead wire )	
	<b>Insulation Resistance</b>	50 M $\Omega$ ( at 500 V DC, between case and lead wire )	
	<b>Vibration</b>	Total amplitude 1.5 mm or 10 G, 10 Hz - 55 Hz - 10 Hz scan for 1 minute, two hours each direction of X, Y and Z	
	<b>Shock</b>	980 m/s <sup>2</sup> ( 100 G ), 3 times each in direction of X, Y and Z	
<b>Temperature Characteristic</b>	$\pm 3\%$ F.S. of detected pressure ( 25 °C ) at temp. Range of 0 ~ 50 °C		
<b>Port Size</b>	PT : 1/8"PT ( R1/8" ), M5 ; NPT : NPT1/8", M5 ; G : G1/8" ( BSPP ), M5		
<b>Lead Wire</b>	Oil-resistance cable ( 0.18 mm <sup>2</sup> )		
<b>Weight</b>	Approx. 50 g ( with 1 meter lead wire )		

## Circuit Wiring Diagrams

MODEL	KP1 - □ - 01	KP1 - □ - 02	KP1 - □ - 03
<b>Connect Diagram</b>			
<b>Characteristics</b>			
<b>Output Method</b>	NPN open collector 30 V 80 mA	PNP open collector 80mA	NPN open collector 30 V 80 mA
<b>Hysteresis</b>	1~10 % of setting pressure ( Adjustable )		3 % F.S.or less ( Fixed )
<b>Setting Points</b>	1 Point		2 Points
<b>Operation Indicating Lamp</b>	Red LED turns on		Out1 = Red, Out2 = Green

## Ordering Information

**K P 1 - 1 - 0 1 - 0 1 - N P T**

### Pressure Range

- 1 : Vacuum ( -101 ~ 0 kPa )
- 2 : Low ( 0 ~ 100 kPa )
- 3 : Positive ( 0 ~ 1 MPa )

### Pressure Port

- PT : 1/8"PT ( R1/8" ), M5
- NPT : NPT1/8", M5
- G : G1/8" ( BSPP ), M5

### Optional Part

M84R - W0072 - 2M : M8 4Pin female connector

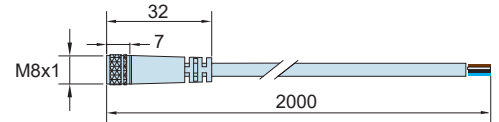

Unit : mm

### Output Specification

- 01 : NPN output
- 02 : PNP output
- 03 : 2 NPN output

### Cable Length / Connector

- 01 : With 1 meter cable
- 03 : With 3 meter cable
- C : With M8 4Pin male connector

## How To Set Pressure

### 1 KP1 - □ - 01, 02

- Remove dust cover to make any adjustments. Replace dust cover when finished to prevent foreign object from entering.
- Pressure setting trimmer (SET) is for setting the output (ON) pressure. Rotate SET trimmer counter-clockwise to increase (Pressure or Vacuum) the ON point. Rotate clockwise will decrease the setting pressure.
- Hysteresis setting trimmer (HYS) is for changing the hysteresis. Rotate trimmer counter-clockwise to increase the range 1 ~ 10 %.
- Use appropriate size screwdriver for the setting trimmers. Gently turn the screwdriver to make adjustments. Do not force the trimmer when it comes to a stop to prevent damage to the setting trimmer.

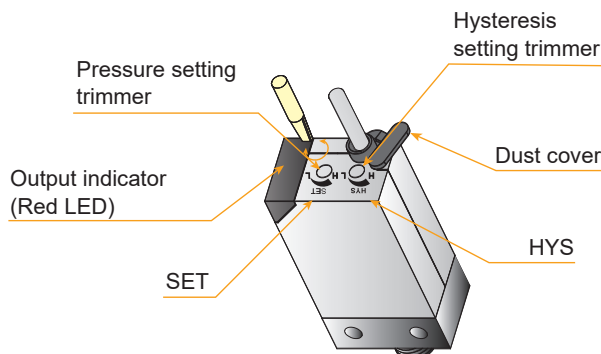

### 2 KP1 - □ - 03

- Remove dust cover to make any adjustments. Replace dust cover when finished to prevent foreign object from entering.
- Pressure setting trimmer (SET 1, SET 2) is for setting the output (ON) pressure. Rotate SET trimmer counter-clockwise to increase (Pressure or Vacuum) the ON point. Rotate clockwise will decrease the setting pressure.
- Hysteresis for models with two outputs is 3 % fixed.

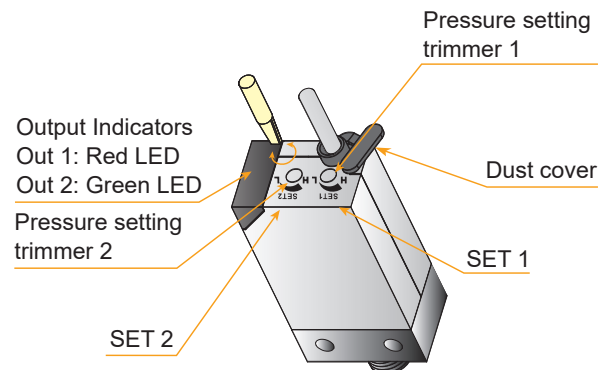

## Dimensions

KP1 - □ - □ - □

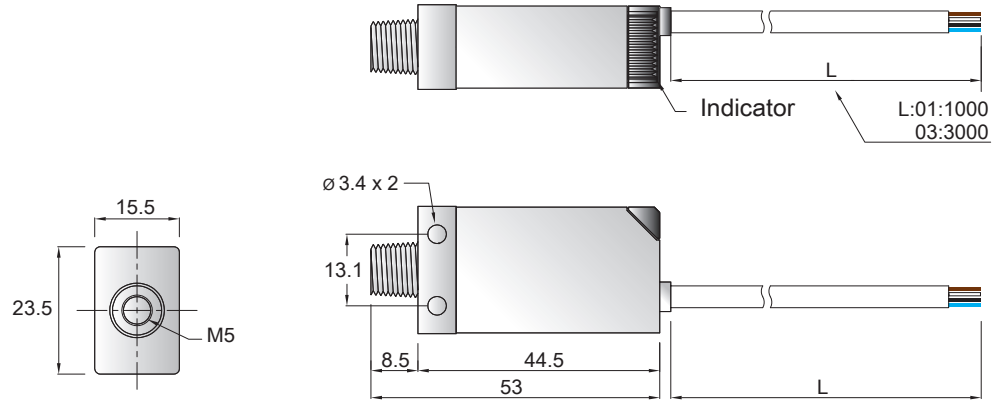

KP1 - □ - C - □

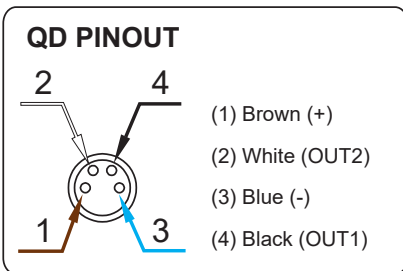
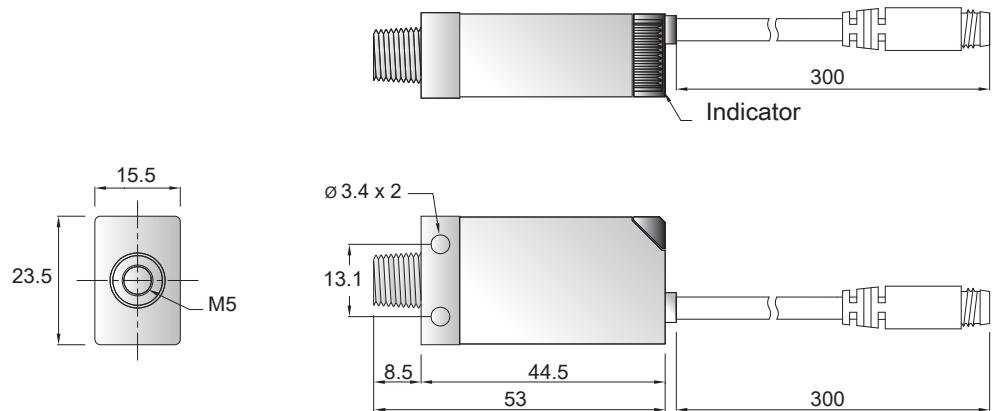

Unit : mm

# KP30 SERIES

## Features

- Set pressure range :  
Compound ( -100.0 ~ 100.0 kPa )  
Vacuum ( 10.0 ~ -101.3 kPa )  
Positive ( -0.100 ~ 1.000 MPa )
- 2 outputs & analog output ( 1 ~ 5 V )
- Hysteresis adjustable
- Programmable pressure unit :  
kPa 、 MPa 、 kgf / cm<sup>2</sup> 、 bar 、 psi 、 inHg 、 mmHg 、 mmH<sub>2</sub>O

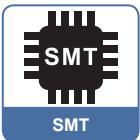
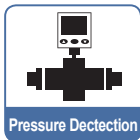
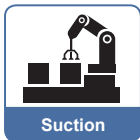

## Features Highlight

### 1 Programmable Pressure Unit

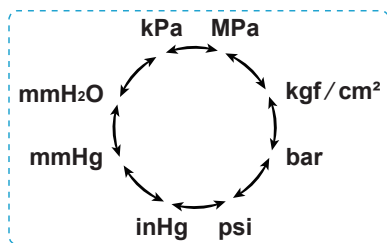

### 2 Key Lock Function

- Key lock mode to prevent unauthorized adjustments  
Press **M** more than 5 seconds to enter key lock mode  
Use **▲** or **▼** to select key lock status



### 3 Analog Output

- 2 outputs & analog output ( 1 ~ 5 V )  
Output range 1 to 5 V, proportional to the pressure range

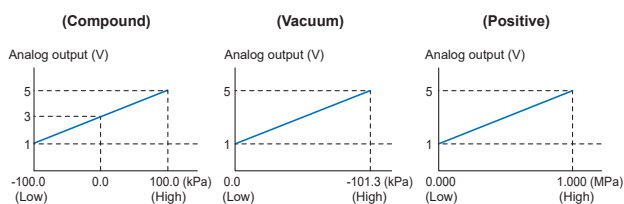

### 4 Hysteresis adjustable

- Output hysteresis (**H**) is adjustable by user

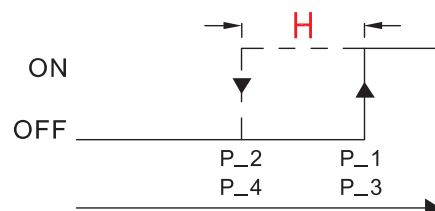

## Specifications

MODEL	KP30C (Compound)	KP30V (Vacuum)	KP30P (Positive)
Rated Pressure Range	-100.0 ~ 100.0 kPa	0.0 ~ -101.3 kPa	0.000 ~ 1.000 MPa
Set Pressure Range	-100.0 ~ 100.0 kPa	10.0 ~ -101.3 kPa	-0.100 ~ 1.000 MPa
Withstand Pressure	300 kPa		1.5 MPa
Fluid	Filtered air, Non-corrosive / Non-flammable gas		
Set Pressure Resolution	kPa	0.1	-
	MPa	-	0.001
	kgf / cm <sup>2</sup>	0.001	0.01
	bar	0.001	0.01
	psi	0.01	0.1
	inHg	0.1	-
	mmHg	1	-
	mmH <sub>2</sub> O	0.1	-
Power Supply Voltage	12 to 24 V DC ±10 %, Ripple ( P-P ) 10 % or less		
Current Consumption	≤ 60 mA		
Switch Output	2NPN : open collector 2 outputs Max. Load Current : 100 mA Max. Supply Voltage : 30 V DC Residual Voltage : ≤ 1 V	2PNP : open collector 2 outputs Max. Load Current : 100 mA Max. Supply Voltage : 24 V DC Residual Voltage : ≤ 1 V	
Repeatability ( Switch Output )	±0.2 % F.S. ±1 digit		
Hysteresis	Hysteresis Mode	Adjustable	
	Window Comparator Mode	Fixed ( 3 digits )	
Response Time	≤ 2.5 ms ( chattering-proof function : 24 ms, 192 ms and 768 ms selectable )		
Output Short Circuit Protection	Yes		
Display	3 ½ digit, 7 segment LED display ( Red ) ( Sampling rate : 5 times / sec. )		
Indicator Accuracy	±2 % F.S. ±1 digit ( Ambient temperature : 25 ±3 °C )		
Switch on Indicator	Indicator Green : OUT1 & Indicator Red : OUT2		
Analog Output ( Only Type Kp30 □ - 01 - □ , Kp30 □ - 03 - □ )	Output voltage : 1 to 5 V ±5 % F.S. ( within rated pressure range ) Linearity : ±1 % F.S.	Output voltage : 1 to 5 V ±2.5 % F.S. ( within rated pressure range ) Linearity : ±1 % F.S.	
Environment	Enclosure	IP 40	
	Ambient Temp. Range	Operation : 0 ~ 50 °C, storage : -20 ~ 60 °C ( No condensation or freezing )	
	Ambient Humidity Range	Operation/Storage : 35 ~ 85 % RH ( No condensation )	
	Withstand Voltage	1000 V AC in 1-min ( between case and lead wire )	
	Insulation Resistance	50 MΩ ( at 500 V DC, between case and lead wire )	
	Vibration	Total amplitude 1.5 mm or 10 G, 10 Hz - 55 Hz - 10 Hz scan for 1 minute, two hours each direction of X, Y and Z	
	Shock	980 m/s <sup>2</sup> ( 100 G ), 3 times each in direction of X, Y and Z	
Temperature Characteristic	±2 % F.S. of detected pressure ( 25 °C ) at temp. Range of 0 ~ 50 °C		
Port Size	F1 : R1/8", M5 ; F2 : NPT1/8", M5 ; F3 : G1/8" ( BSPP ), M5		
Lead Wire	Oil-resistance cable ( 0.15 mm <sup>2</sup> )		
Weight	Approx. 67 g ( with 2 meter lead wire )		

## Installation Precautions

- When mounting, always use the wrench on the metallic area near the pressure port. Never apply a wrench to the plastic body, it will damage the sensor.
- Over tightening may cause damages to the port thread, mounting bracket and pressure sensor. Under tightening may result loosen or leakage.
- Apply pressure and power after installation and make necessary adjustments and inspect any possible signs of leakage to ensure proper installation.

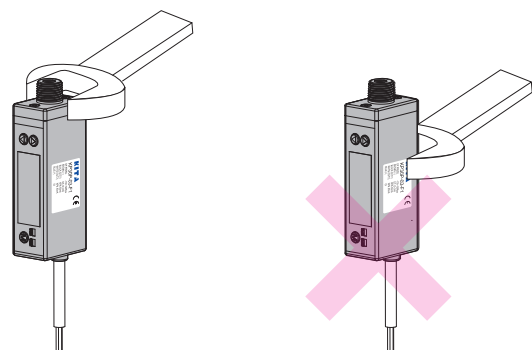

# KP30 SERIES

## Panel Description

- (▲) Button**  
 Use the (▲) button to change setting mode and pre-set desired value.
- (▼) Button**  
 Use the (▼) button to change setting mode and pre-set desired value.
- Switch ( OUT1 )**  
 ( Green LED )
- Switch ( OUT2 )**  
 ( Red LED )
- Setting Button**  
 Change setting mode and pre-set final desired value.
- 3½ Digit LED Display**  
 Pressure value display.



## Circuit Wiring Diagrams

KP30 □ - 01 - □ - □

NPN Output & Analog Output ( 1 ~ 5 V )

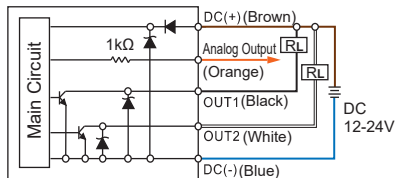

KP30 □ - 02 - □ - □

NPN Output

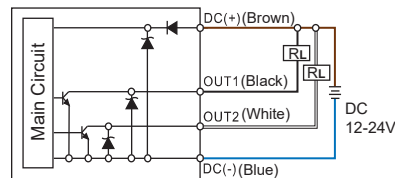

KP30 □ - 03 - □ - □

PNP Output & Analog Output ( 1 ~ 5 V )

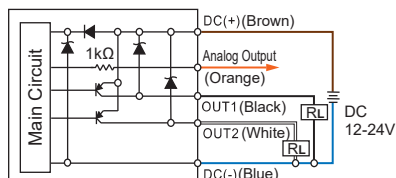

KP30 □ - 04 - □ - □

PNP Output

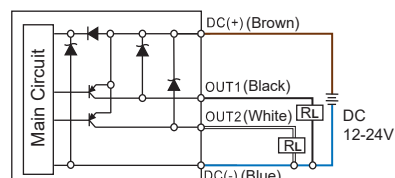

## Ordering Information

K P 3 0 C - 0 1 - F 1 - □

### Pressure Range

C : Compound ( -100.0 ~ 100.0 kPa )  
 V : Vacuum ( 10.0 ~ -101.3 kPa )  
 P : Positive ( -0.100 ~ 1.000 MPa )

### Pressure Port

F1 : R1/8", M5  
 F2 : NPT1/8", M5  
 F3 : G1/8" ( BSPP ), M5

### Optional Part

M84R - W0085 - 2M : M8 4Pin female connector

### Output Specification

01 : 2 NPN output & Analog output ( 1 ~ 5 V )  
 02 : 2 NPN output  
 03 : 2 PNP output & Analog output ( 1 ~ 5 V )  
 04 : 2 PNP output

### Cable Length / Connector

Blank : With 2 meter cable  
 QD : With M8 4Pin male connector  
 \* ( Only type KP30 □ - 02 - □ , KP30 □ - 04 - □ )

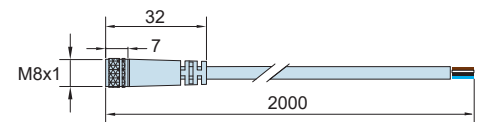

Unit : mm

## Dimensions

KP30□ - □ - □

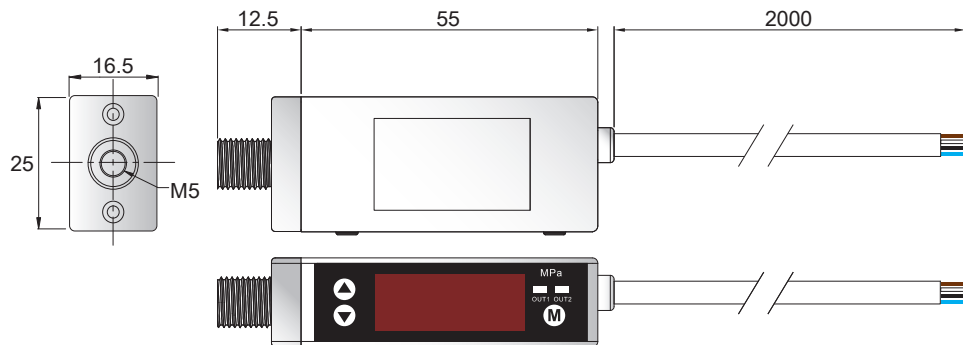

KP30□ - □ - □ - QD

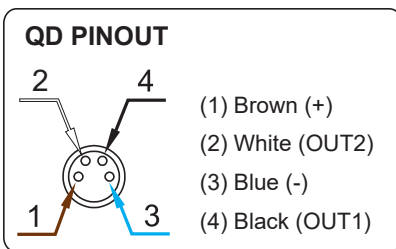
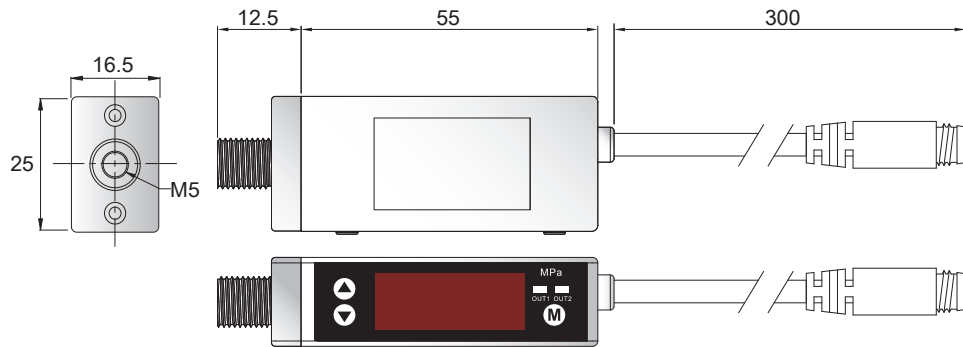

Unit : mm

## Features

- 3-color digital LCD display
- Copy function
- Programmable pressure unit :  
kPa、MPa、kgf/cm<sup>2</sup>、bar、psi、inHg、mmHg
- Dual LCD display allows setting value to be displayed
- Key lock indicator
- Power-save mode

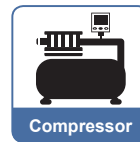
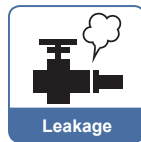
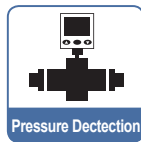
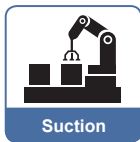

## Features Highlight

### 1 Quick Installation

- Save Installation Time
- Easy Removal

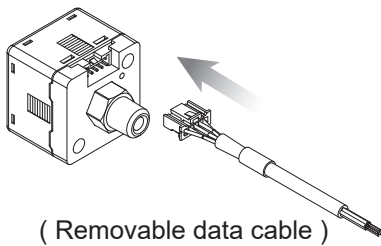

### 2 Copy Setting

- Avoid setting errors
- Reduce setting time



### 3 Setting Value Easy Indication

- User can easily observe the setting value from sub-display.

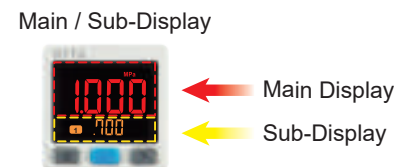

### 4 2-Color Main Display

- User programmable color mode, for different setting conditions.



	500	500	600	700
ON	Green	Red	Green	Red
OFF	Red	Green	Green	Red

### 5 OPS Quick Setting

- Sub-display allows changing the parameter directly, reduce setting step by 3/4.

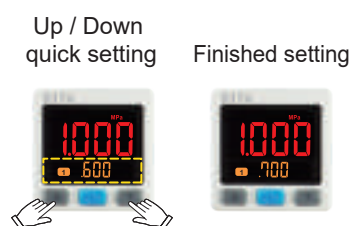

### 6 Easy Unit Identification

- Conversion unit is on display and easy to read.



## Specifications

MODEL	KP43C (Compound)	KP43V (Vacuum)	KP43P (Positive)
Rated Pressure Range	-100.0 ~ 100.0 kPa	0.0 ~ -101.3 kPa	0.000 ~ 1.000 MPa
Set Pressure Range	-101.0 ~ 101.0 kPa	10.0 ~ -101.3 kPa	-0.100 ~ 1.000 MPa
Withstand Pressure	300 kPa		1.5 MPa
Fluid	Filtered air, Non-corrosive / Non-flammable gas		
Set Pressure Resolution	kPa	0.1	-
	MPa	-	0.001
	kgf / cm <sup>2</sup>	0.001	0.01
	bar	0.001	0.01
	psi	0.01	0.1
	inHg	0.1	-
	mmHg	1	-
Power Supply Voltage	12 to 24 V DC $\pm 10\%$ , Ripple ( P-P ) 10 % or less		
Current Consumption	$\leq 40$ mA ( With no load )		
Switch Output	2NPN : open collector 2 outputs Max. Load Current : 125 mA Max. Supply Voltage : 30 V DC Residual Voltage : $\leq 1.5$ V	2PNP : open collector 2 outputs Max. Load Current : 125 mA Max. Supply Voltage : 24 V DC Residual Voltage : $\leq 1.5$ V	
Repeatability ( Switch Output )	$\pm 0.2\%$ F.S. $\pm 1$ digit		
Hysteresis	One Point Set Mode	Adjustable *1	
	Hysteresis Mode		
	Window Comparator Mode		
Response Time	$\leq 2.5$ ms ( chattering-proof function : 25 ms, 100 ms, 250 ms, 500 ms, 1000 ms and 1500 ms selectable )		
Output Short Circuit Protection	Yes		
Display	3 ½ digital, 7 segment LCD display ( Red / Green / Orange ) ( Sampling rate : 5 times / sec. )		
Indicator Accuracy	$\pm 2\%$ F.S. $\pm 1$ digit ( ambient temperature : $25 \pm 3$ °C )		
Switch on Indicator	Orange indicator 1 : OUT1 & Orange indicator 2 : OUT2		
Analog Output ( Voltage Output ) *2	Output Voltage : 1 to 5 V $\pm 2.5\%$ F.S. ( within rated pressure range ) Linearity : $\pm 1\%$ F.S. Output Impedance : about 1 k $\Omega$		
Analog Output ( Current Output ) *3	Output Current : 4 to 20 mA $\pm 2.5\%$ F.S. ( within rated pressure range ) Linearity : $\pm 1\%$ F.S. Max.Load Impedance : 300 $\Omega$ at power supply of 12 V 600 $\Omega$ at power supply of 24 V Min.Load Impedance : 50 $\Omega$		
Environment	Enclosure	IP 40	
	Ambient temp. range	Operation : 0 ~ 50 °C, Storage : -10 ~ 60 °C ( No condensation or freezing )	
	Ambient humidity range	Operation / Storage : 35 ~ 85 % RH ( No condensation )	
	Withstand voltage	1000 V AC in 1-min ( between case and lead wire )	
	Insulation resistance	50 M $\Omega$ ( at 500 V DC, between case and lead wire )	
	Vibration	Total amplitude 1.5 mm or 10 G, 10 Hz - 55 Hz - 10 Hz scan for 1 minute, two hours each direction of X, Y and Z	
Shock	100 m/s <sup>2</sup> ( 10 G ), 3 times each in direction of X, Y and Z		
Temperature characteristic	$\pm 2.5\%$ F.S. of detected pressure ( 25 °C ) at temp. Range of 0 ~ 50 °C		
Port size	F1 : R1/8", M5 ; F2 : NPT1/8", #10-32 UNF ; F3 : G1/8" ( BSPP ), M5		
Lead wire	Oil-resistance cable ( 0.15 mm <sup>2</sup> )		
Weight	Approx. 80 g ( with 2 meter lead wire )		

### NOTE :

\*1 : Hysteresis value is adjustable within 1 ~ 8 digits for one point set mode and window comparator mode.

\*2 : If analog voltage output is selected, the analog current output cannot be selected at the same time.

\*3 : If analog current output is selected, the analog voltage output cannot be selected at the same time.

# KP43 SERIES

# General Pressure Sensor

## Panel Description

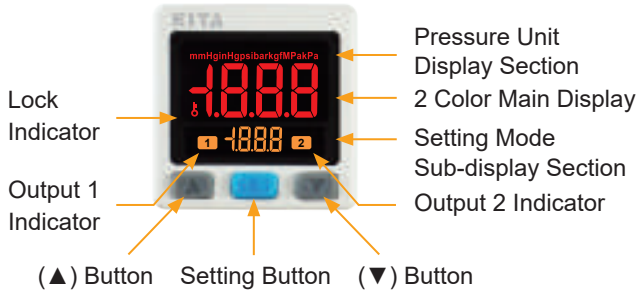

## Installation Precautions

- When mounting, always use the wrench on the metallic area near the pressure port. Never apply a wrench to the plastic body, it will damage the sensor.
- Over tightening may cause damages to the port thread, mounting bracket and pressure sensor. Under tightening may result loosen or leakage.
- Apply pressure and power after installation and make necessary adjustments and inspect any possible signs of leakage to ensure proper installation.

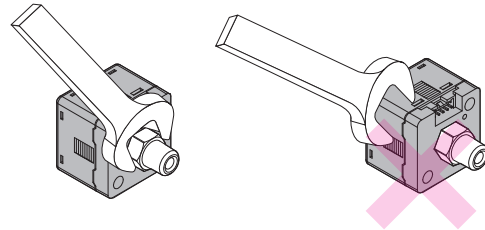

## Circuit Wiring Diagrams

### KP43□ - 010 - □

2NPN + Analog Output ( 1 ~ 5 V )

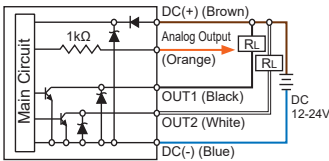

### KP43□ - 011 - □

2NPN + Analog Output ( 4 ~ 20 mA )

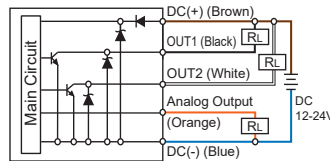

### KP43□ - 02 - □

2NPN + Copy Function

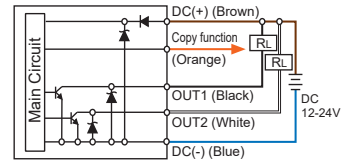

### KP43□ - 030 - □

2PNP + Analog Output ( 1 ~ 5 V )

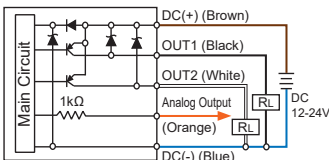

### KP43□ - 031 - □

2PNP + Analog Output ( 4 ~ 20 mA )

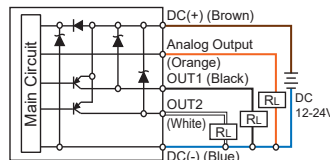

### KP43□ - 04 - □

2PNP + Copy Function

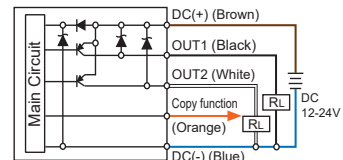

## Ordering Information

**K P 4 3 C - 0 1 0 - F 1**

### Pressure Range

C : Compound ( -101.0 ~ 101.0 kPa )  
V : Vacuum ( 10.0 ~ -101.3 kPa )  
P : Positive ( -0.100 ~ 1.000 MPa )

### Output Specifications

010 : 2 NPN Output & Analog Output ( 1 ~ 5 V )  
011 : 2 NPN Output & Analog Output ( 4 ~ 20 mA )  
02 : 2 NPN Output & Copy Function  
030 : 2 PNP Output & Analog Output ( 1 ~ 5 V )  
031 : 2 PNP Output & Analog Output ( 4 ~ 20 mA )  
04 : 2 PNP Output & Copy Function

### Pressure Port

F1 : R1/8", M5  
F2 : NPT1/8", #10-32UNF  
F3 : G1/8" ( BSPP ), M5

### Optional Parts

BT-12 : Mounting bracket  
BT-13 : Mounting bracket  
PA-C : Panel adapter  
PA-D : Panel adapter +  
Front protective lid

### Optional Parts

- Mounting bracket : BT-12 / BT-13



- Panel adapter : PA-C



- Panel adapter + Front protective lid : PA-D



## Dimensions

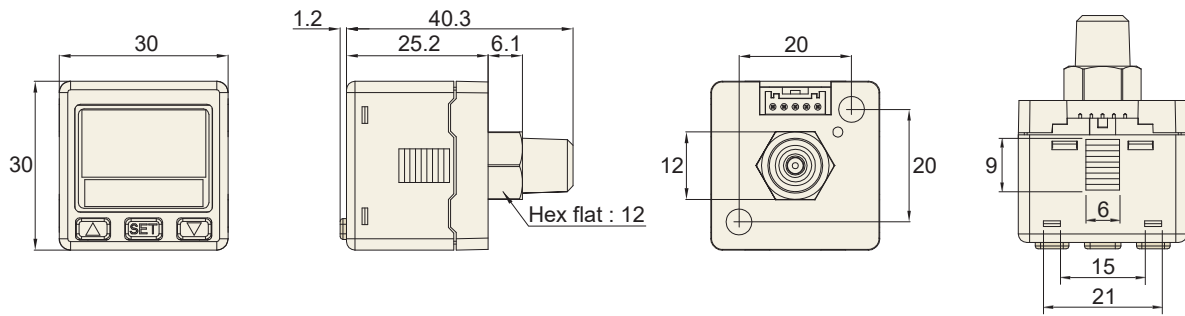

## Optional Parts Dimensions

### 1 Mounting Bracket

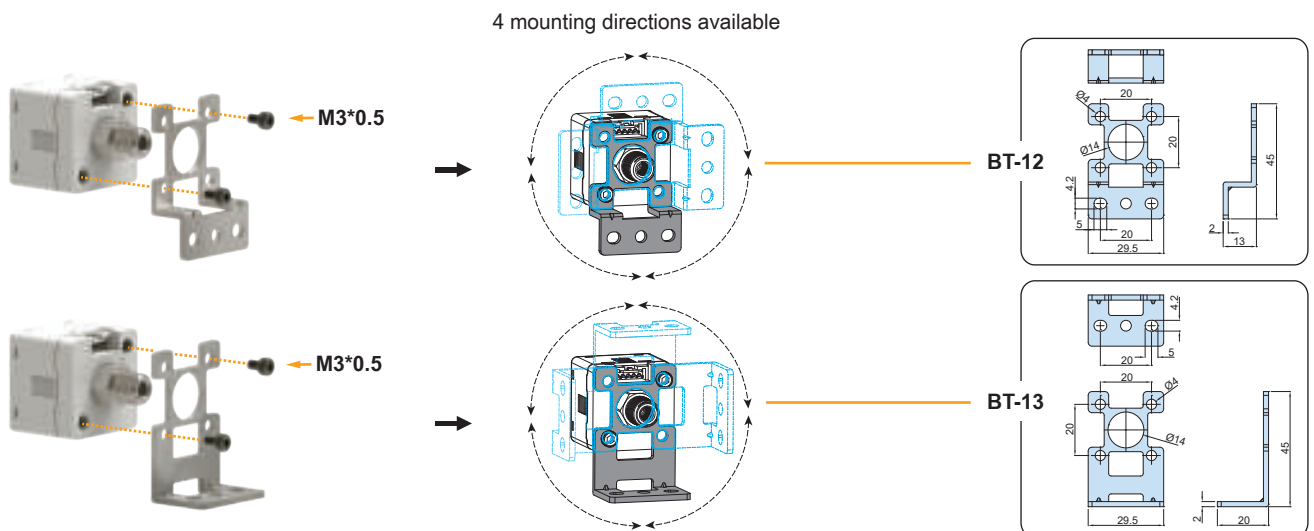

### 2 Panel Mount Adapter + Front Protective Lid

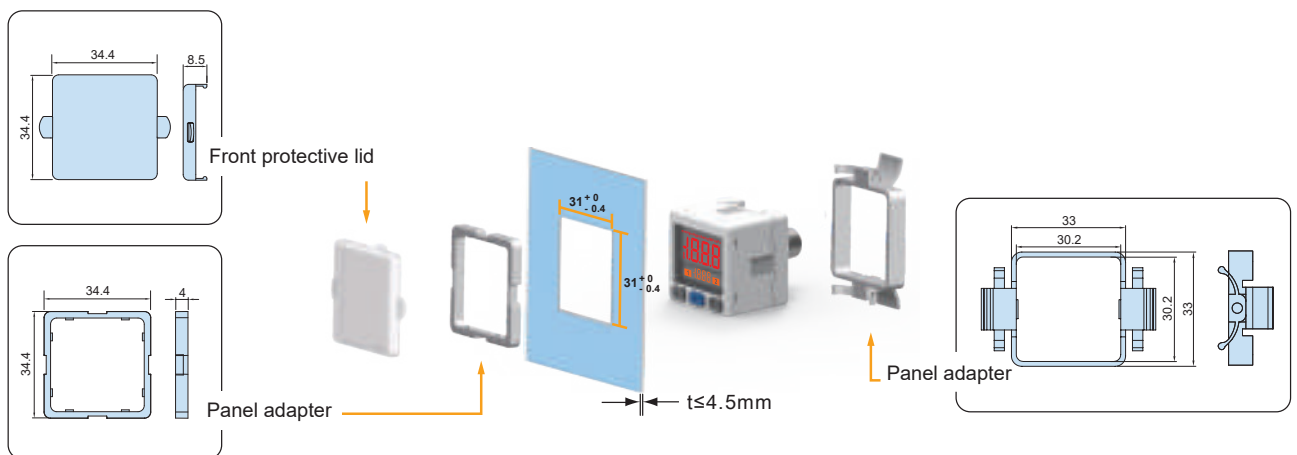

Unit : mm

# KP45 SERIES

# IP65 Pressure Sensor

## Features

- 2-color digital LCD display
- Copy function
- Programmable pressure unit :  
kPa \ MPa \ kgf / cm<sup>2</sup> \ bar \ psi \ inHg
- IP65 enclosure

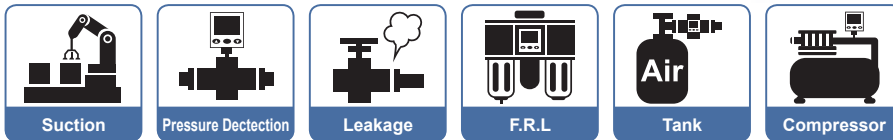

## Features Highlight

### 1 Quick Installation

- Save installation time
- Easy removal

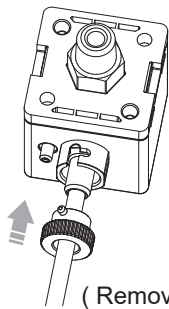

( Removable data cable )

### 2 Copy Setting

- Avoid setting errors
- Reduce setting time



( Original Parameter )

( Copied )

### 3 Easy Unit Identification

- Conversion unit is on display and easy to read.



### 4 2-Color Display

- User programmable color mode, for different setting conditions.



	500	500	600	600
ON	Green	Red	Green	Red
OFF	Red	Green	Green	Red

### 5 IP65 Compliance



### 6 Environmental Protection Design

- RoHS Compliance / Without Harmful Substance



## Specifications

MODEL	KP45C (Compound)	KP45V (Vacuum)	KP45P (Positive)
<b>Rated Pressure Range</b>	-100.0 ~ 100.0 kPa	0.0 ~ -101.3 kPa	0.000 ~ 1.000 MPa
<b>Set Pressure Range</b>	-101.0 ~ 101.0 kPa	10.0 ~ -101.3 kPa	-0.100 ~ 1.000 MPa
<b>Withstand Pressure</b>	300 kPa		1.5 MPa
<b>Fluid</b>	Filtered air, Non-corrosive / Non-flammable gas		
<b>Set Pressure Resolution</b>	kPa	0.1	-
	MPa	-	0.001
	kgf / cm <sup>2</sup>	0.001	0.01
	bar	0.001	0.01
	psi	0.01	0.1
	inHg	0.1	-
<b>Power Supply Voltage</b>	12 to 24 V DC $\pm 10\%$ , Ripple ( P-P ) 10 % or less ( UL class 2 )		
<b>Current Consumption</b>	$\leq 40$ mA ( With no load )		
<b>Switch Output</b>	2NPN : open collector 2 outputs Max. Load Current : 125 mA Max. Supply Voltage : 30 V DC Residual Voltage : $\leq 1.5$ V	2PNP : open collector 2 outputs Max. Load Current : 125 mA Max. Supply Voltage : 24 V DC Residual Voltage : $\leq 1.5$ V	
<b>Repeatability ( Switch Output )</b>	$\pm 0.2\%$ F.S. $\pm 1$ digit		
<b>Hysteresis</b>	One Point Set Mode	Adjustable *1	
	Hysteresis Mode		
	Window Comparator Mode		
<b>Response Time</b>	$\leq 2.5$ ms ( chattering-proof function : 25 ms, 100 ms, 250 ms, 500 ms, 1000 ms and 1500 ms selectable )		
<b>Output Short Circuit Protection</b>	Yes		
<b>Display</b>	3 ½ digital, 7 segment LCD display ( Red / Green / Orange ) ( Sampling rate : 5 times / sec. )		
<b>Indicator Accuracy</b>	$\pm 2\%$ F.S. $\pm 1$ digit ( ambient temperature : 25 $\pm 3$ °C )		
<b>Switch on Indicator</b>	Orange indicator 1 : OUT1 & Orange indicator 2 : OUT2		
<b>Analog Output ( Voltage Output ) *2</b>	Output Voltage : 1 to 5 V $\pm 2.5\%$ F.S. ( within rated pressure range ) Linearity : $\pm 1\%$ F.S. Output Impedance : about 1 k $\Omega$		
<b>Analog Output ( Current Output ) *3</b>	Output Current : 4 to 20 mA $\pm 2.5\%$ F.S. ( within rated pressure range ) Linearity : $\pm 1\%$ F.S. Max.Load Impedance : 250 $\Omega$ at power supply of 12 V 600 $\Omega$ at power supply of 24 V Min.Load Impedance : 50 $\Omega$		
<b>Environment</b>	<b>Enclosure</b>	IP 65 *4	
	<b>Ambient Temp. Range</b>	Operation : 0 ~ 50 °C, Storage : -10 ~ 60 °C ( No condensation or freezing )	
	<b>Ambient Humidity Range</b>	Operation / Storage : 35 ~ 85 % RH ( No condensation )	
	<b>Withstand Voltage</b>	1000 V AC in 1-min ( between case and lead wire )	
	<b>Insulation Resistance</b>	50 M $\Omega$ ( at 500 V DC, between case and lead wire )	
	<b>Vibration</b>	Total amplitude 1.5 mm or 10 G, 10 Hz - 55 Hz - 10 Hz scan for 1 minute, two hours each direction of X, Y and Z	
	<b>Shock</b>	100 m/s <sup>2</sup> ( 10 G ), 3 times each in direction of X, Y and Z	
<b>Temperature Characteristic</b>	$\pm 2\%$ F.S. of detected pressure ( 25 °C ) at temp. Range of 0 ~ 50 °C		
<b>Port Size</b>	F1 : R1/8", M5 ; F2 : NPT1/8", #10-32 UNF ; F3 : G1/8" ( BSPP ), M5 F1C : Rc1/8" ; F2C : NPT1/8" ; F3C : G1/8" ( BSPP )		
<b>Lead Wire</b>	Oil-resistance cable ( 0.15 mm <sup>2</sup> )		
<b>Weight ( With 2 Meter Lead Wire )</b>	Approx. 86g ( Port F1 ~ F3 ) ; Approx. 114g ( Port F1C ~ F3C )		

### NOTE :

\*1 : Hysteresis value is adjustable within 1 ~ 8 digits for one point set mode and window comparator mode.

\*2 : If analog voltage output is selected, the analog current output cannot be selected at the same time.

\*3 : If analog current output is selected, the analog voltage output cannot be selected at the same time.

\*4 : Air tube must be installed to maintain IP65.

# KP45 SERIES

# IP65 Pressure Sensor

## Panel Description



## Installation Precautions

- When mounting, always use the wrench on the metallic area near the pressure port. Never apply a wrench to the plastic body, it will damage the sensor.
- Over tightening may cause damages to the port thread, mounting bracket and pressure sensor. Under tightening may result loosen or leakage.
- Apply pressure and power after installation and make necessary adjustments and inspect any possible signs of leakage to ensure proper installation.

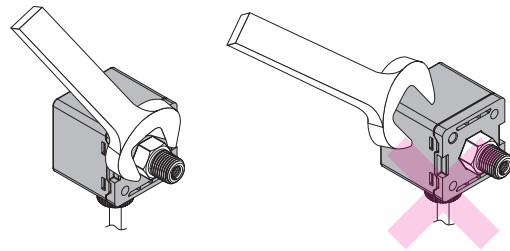

## Circuit Wiring Diagrams

**KP45 □ - 010 - □**  
2 NPN + Analog Output ( 1 ~ 5 V )

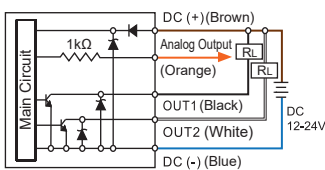

**KP45 □ - 011 - □**  
2 NPN + Analog Output ( 4 ~ 20 mA )

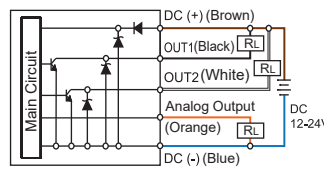

**KP45 □ - 02 - □**  
2 NPN + Copy Function

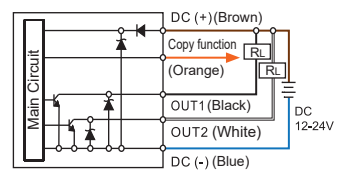

**KP45 □ - 030 - □**  
2 PNP + Analog Output ( 1 ~ 5 V )

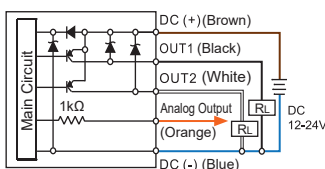

**KP45 □ - 031 - □**  
2 PNP + Analog Output ( 4 ~ 20 mA )

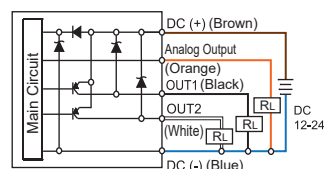

**KP45 □ - 04 - □**  
2 PNP + Copy Function

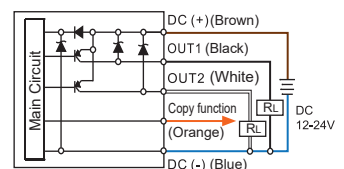

## Ordering Information

**K P 4 5 C - 0 1 0 - F 1**

### Pressure Range

- C : Compound (-101.0 ~ 101.0 kPa)
- V : Vacuum (10.0 ~ -101.3 kPa)
- P : Positive (-0.100 ~ 1.000 MPa)

### Output Specifications

- 010 : 2 NPN Output & Analog Output ( 1 ~ 5 V )
- 011 : 2 NPN Output & Analog Output ( 4 ~ 20 mA )
- 02 : 2 NPN Output & Copy Function
- 030 : 2 PNP Output & Analog Output ( 1 ~ 5 V )
- 031 : 2 PNP Output & Analog Output ( 4 ~ 20 mA )
- 04 : 2 PNP Output & Copy Function

### Pressure Port

- F1 : R1/8", M5 , with external threads
- F2 : NPT1/8", #10-32UNF, with external threads
- F3 : G1/8" ( BSPP ), M5, with external threads
- F1C : Rc1/8", with internal threads
- F2C : NPT1/8", with internal threads
- F3C : G1/8" ( BSPP ), with internal threads

### Optional Parts

- BT-10 : Mounting bracket ( for Pressure Port F1 ~ F3 )
- BT-11 : Mounting bracket ( for Pressure Port F1 ~ F3 )
- BT-1 : Mounting bracket ( for Pressure Port F1C ~ F3C )
- BT-17 : Mounting bracket ( for Pressure Port F1C ~ F3C )
- PA-E : Panel adapter
- PA-F : Panel adapter + Front protective lid

### Optional Parts

- Mounting Bracket :
  - BT-10 / BT-11 ( For Pressure Port F1 ~ F3 )
  - BT-1 / BT-17 ( For Pressure Port F1C ~ F3C )
- Panel Adapter : PA-E
- Panel Adapter + Front Protective Lid : PA-F





### Features

- 2-color digital LCD display
- Copy function
- Programmable pressure unit :  
kPa 、 kgf / cm<sup>2</sup> 、 bar 、 psi 、 inHg
- IP65 enclosure

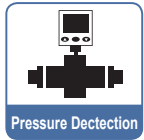

### Features Highlight

#### 1 Quick Installation

- Save installation time
- Easy removal

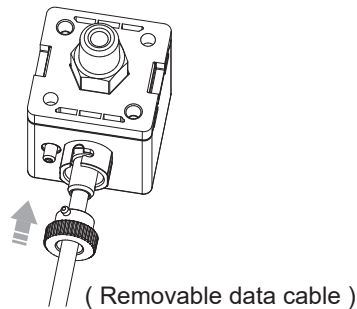

#### 2 Copy Setting

- Avoid setting errors
- Reduce setting time

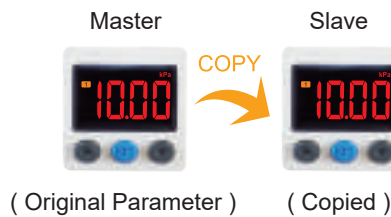

#### 3 Easy Unit Identification

- Conversion unit is on display and easy to read.



#### 4 2-Color Display

- User programmable color mode, for different setting conditions.



	5.00	5.00	5.00	5.00
ON	Green	Red	Green	Red
OFF	Red	Green	Green	Red

#### 5 IP65 Compliance



#### 6 Environmental Protection Design

- RoHS Compliance / Without Harmful Substance



## Specifications

MODEL		KP45S (Compound)		
				
<b>Rated Pressure Range</b>		-10.00 ~ 10.00 kPa		
<b>Set Pressure Range</b>		-10.10 ~ 10.10 kPa		
<b>Withstand Pressure</b>		20 kPa		
<b>Fluid</b>		Filtered air, Non-corrosive / Non-flammable gas		
<b>Set Pressure Resolution</b>	kPa	0.01		
	MPa	-		
	kgf / cm <sup>2</sup>	0.001		
	bar	0.001		
	psi	0.01		
	inHg	0.1		
<b>Power Supply Voltage</b>		12 to 24 V DC ±10 %, Ripple ( P-P ) 10 % or less		
<b>Current Consumption</b>		≤ 40 mA ( With no load )		
<b>Switch Output</b>		<table style="width: 100%; border: none;"> <tr> <td style="width: 50%; border: none;">                     2NPN : open collector 2 outputs                      Max. Load Current : 125 mA                      Max. Supply Voltage : 30 V DC                      Residual Voltage : ≤ 1.5 V                 </td> <td style="width: 50%; border: none;">                     2PNP : open collector 2 outputs                      Max. Load Current : 125 mA                      Max. Supply Voltage : 24 V DC                      Residual Voltage : ≤ 1.5 V                 </td> </tr> </table>	2NPN : open collector 2 outputs Max. Load Current : 125 mA Max. Supply Voltage : 30 V DC Residual Voltage : ≤ 1.5 V	2PNP : open collector 2 outputs Max. Load Current : 125 mA Max. Supply Voltage : 24 V DC Residual Voltage : ≤ 1.5 V
2NPN : open collector 2 outputs Max. Load Current : 125 mA Max. Supply Voltage : 30 V DC Residual Voltage : ≤ 1.5 V	2PNP : open collector 2 outputs Max. Load Current : 125 mA Max. Supply Voltage : 24 V DC Residual Voltage : ≤ 1.5 V			
<b>Repeatability ( Switch Output )</b>		±0.2 % F.S. ±1 digit		
<b>Hysteresis</b>	One Point Set Mode	Adjustable *1		
	Hysteresis Mode			
	Window Comparator Mode			
<b>Response Time</b>		≤ 2.5 ms ( chattering-proof function : 25 ms, 100 ms, 250 ms, 500 ms, 1000 ms and 1500 ms selectable )		
<b>Output Short Circuit Protection</b>		Yes		
<b>Display</b>		3 ½ digital, 7 segment LCD display ( Red / Green / Orange ) ( Sampling rate : 5 times / sec. )		
<b>Indicator Accuracy</b>		±2 % F.S. ±1 digit ( ambient temperature : 25 ±3 °C )		
<b>Switch on Indicator</b>		Orange indicator 1 : OUT1 & Orange indicator 2 : OUT2		
<b>Analog Output ( Voltage Output ) *2</b>		Output Voltage : 1 to 5 V ±2.5 % F.S. ( within rated pressure range ) Linearity : ±1 % F.S. Output Impedance : about 1 kΩ		
<b>Analog Output ( Current Output ) *3</b>		Output Current : 4 to 20 mA ±2.5 % F.S. ( within rated pressure range ) Linearity : ±1 % F.S. Max.Load Impedance : 250 Ω at power supply of 12 V 600 Ω at power supply of 24 V Min.Load Impedance : 50 Ωz		
<b>Environment</b>	<b>Enclosure</b>	IP 65 *4		
	<b>Ambient Temp. Range</b>	Operation : 0 ~ 50 °C, Storage : -10 ~ 60 °C ( No condensation or freezing )		
	<b>Ambient Humidity Range</b>	Operation / Storage : 35 ~ 85 % RH ( No condensation )		
	<b>Withstand Voltage</b>	1000 V AC in 1-min ( between case and lead wire )		
	<b>Insulation Resistance</b>	50 MΩ ( at 500 V DC, between case and lead wire )		
	<b>Vibration</b>	Total amplitude 1.5 mm or 10 G, 10 Hz - 55 Hz - 10 Hz scan for 1 minute, two hours each direction of X, Y and Z		
	<b>Shock</b>	100 m/s <sup>2</sup> ( 10 G ), 3 times each in direction of X, Y and Z		
<b>Temperature Characteristic</b>		±2 % F.S. of detected pressure ( 25 °C ) at temp. Range of 0 ~ 50 °C		
<b>Port Size</b>		F1 : R1/8", M5 ; F2 : NPT1/8", #10-32UNF ; F3 : G1/8" ( BSPP ), M5 F1C : Rc1/8" ; F2C : NPT1/8" ; F3C : G1/8" ( BSPP )		
<b>Lead Wire</b>		Oil-resistance cable ( 0.15 mm <sup>2</sup> )		
<b>Weight ( With 2 Meter Lead Wire )</b>		Approx. 86g ( Port F1 ~ F3 ) ; Approx. 114g ( Port F1C ~ F3C )		

**NOTE :**

\*1 : Hysteresis value is adjustable within 1 ~ 8 digits for one point set mode and window comparator mode.

\*2 : If analog voltage output is selected, the analog current output cannot be selected at the same time.

\*3 : If analog current output is selected, the analog voltage output cannot be selected at the same time.

\*4 : Air tube must be installed to maintain IP65.

# KP45S SERIES

## IP65 Low Pressure Sensor

### Panel Description



### Installation Precautions

- When mounting, always use the wrench on the metallic area near the pressure port. Never apply a wrench to the plastic body, it will damage the sensor.
- Over tightening may cause damages to the port thread, mounting bracket and pressure sensor. Under tightening may result loosen or leakage.
- Apply pressure and power after installation and make necessary adjustments and inspect any possible signs of leakage to ensure proper installation.

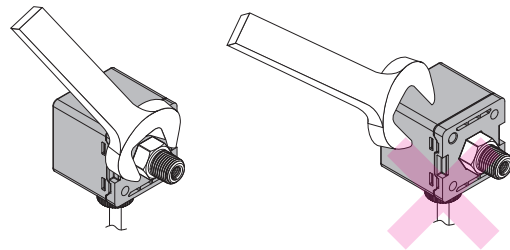

### Circuit Wiring Diagrams

**KP45S □ - 010 - □**  
2 NPN + Analog Output ( 1 ~ 5 V )

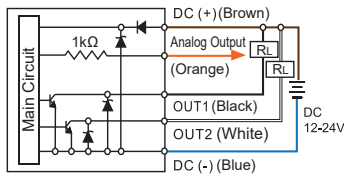

**KP45S □ - 011 - □**  
2 NPN + Analog Output ( 4 ~ 20 mA )

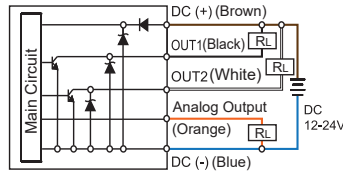

**KP45S □ - 02 - □**  
2 NPN + Copy Function

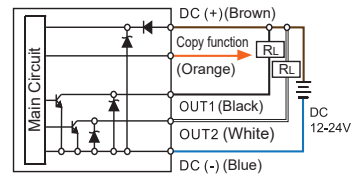

**KP45S □ - 030 - □**  
2 PNP + Analog Output ( 1 ~ 5 V )

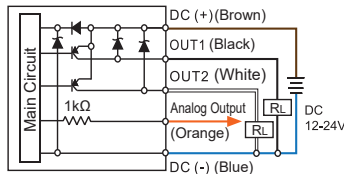

**KP45S □ - 031 - □**  
2 PNP + Analog Output ( 4 ~ 20 mA )

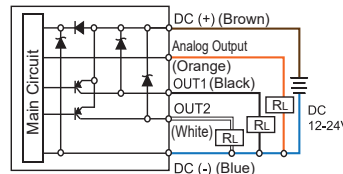

**KP45S □ - 04 - □**  
2 PNP + Copy Function

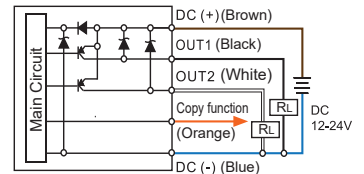

### Ordering Information

**K P 4 5 S - 0 1 0 - F 1**

#### Pressure Range

S : Compound ( -10.10 ~ 10.10 kPa )

#### Output Specifications

010 : 2 NPN Output & Analog Output ( 1 ~ 5 V )  
011 : 2 NPN Output & Analog Output ( 4 ~ 20 mA )  
02 : 2 NPN Output & Copy Function  
030 : 2 PNP Output & Analog Output ( 1 ~ 5 V )  
031 : 2 PNP Output & Analog Output ( 4 ~ 20 mA )  
04 : 2 PNP Output & Copy Function

#### Pressure Port

F1 : R1/8", M5, with external threads  
F2 : NPT1/8", #10-32UNF, with external threads  
F3 : G1/8" ( BSPP ), M5, with external threads  
F1C : Rc1/8", with internal threads  
F2C : NPT1/8", with internal threads  
F3C : G1/8" ( BSPP ), with internal threads

#### Optional Parts

BT-10 : Mounting bracket ( for Pressure Port F1 ~ F3 )  
BT-11 : Mounting bracket ( for Pressure Port F1 ~ F3 )  
BT-1 : Mounting bracket ( for Pressure Port F1C ~ F3C )  
BT-17 : Mounting bracket ( for Pressure Port F1C ~ F3C )  
PA-E : Panel adapter  
PA-F : Panel adapter + Front protective lid

#### Optional Parts

- Mounting Bracket :  
BT-10 / BT-11 ( For Pressure Port F1 ~ F3 )  
BT- 1 / BT-17 ( For Pressure Port F1C ~ F3C )

- Panel Adapter : PA-E

- Panel Adapter + Front Protective Lid : PA-F



## Dimensions

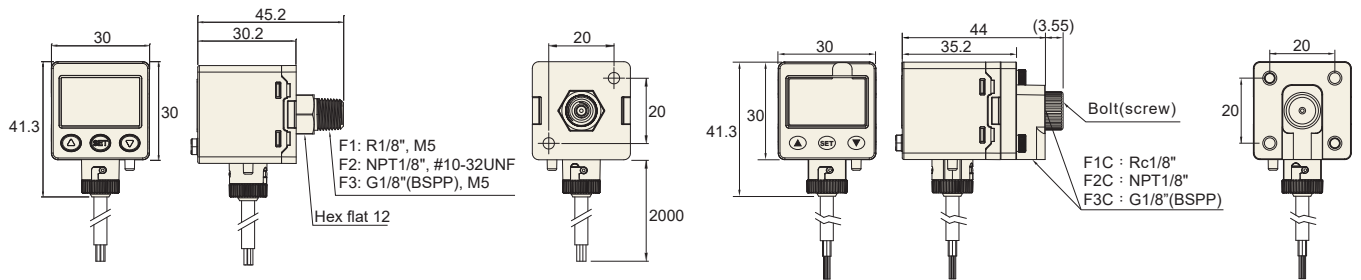

## Optional Parts Dimensions

### 1 Mounting Bracket

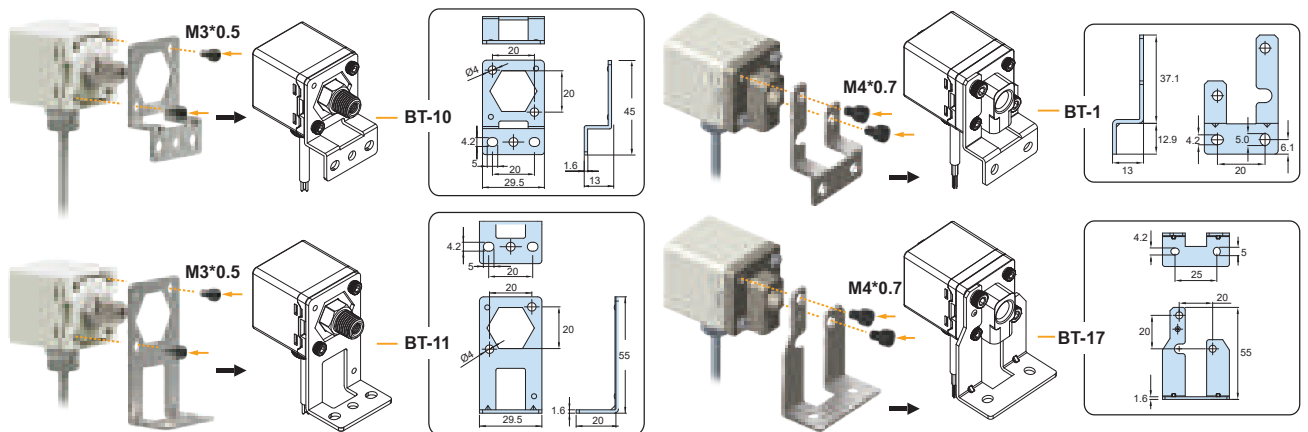

### 2 Panel Mount Adapter + Front Protective Lid

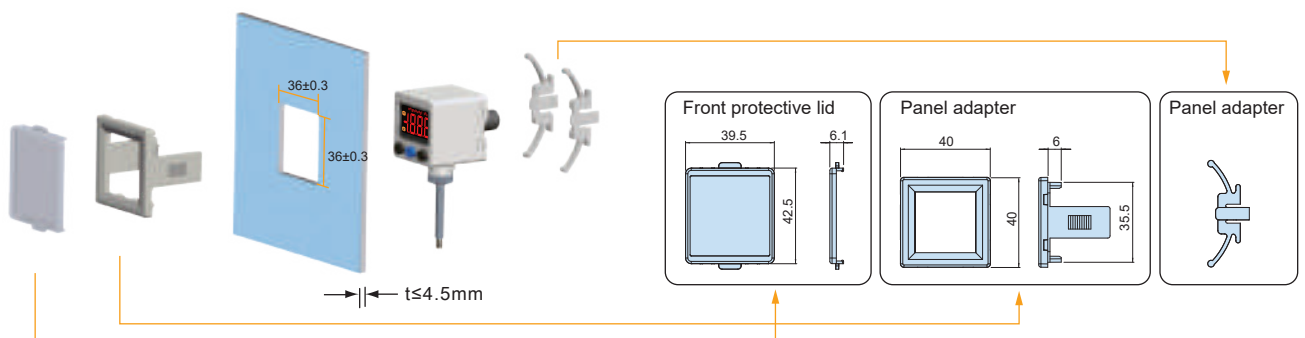

### 3 IP65 Protector

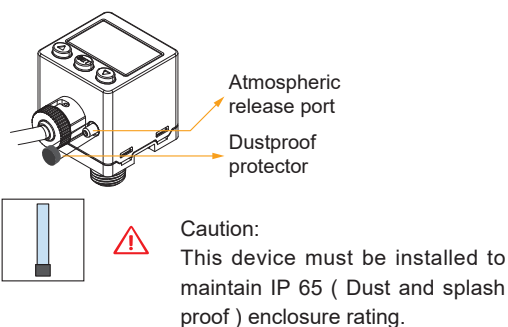

### 4 KP45S Accessory for Pressure Port F1C ~ F3C

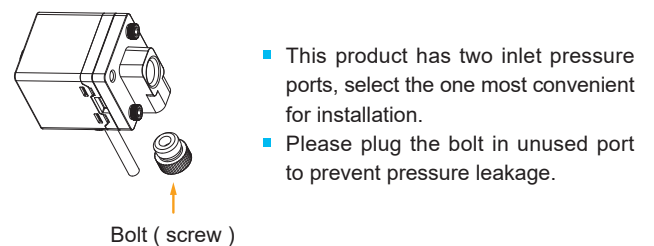

- This product has two inlet pressure ports, select the one most convenient for installation.
- Please plug the bolt in unused port to prevent pressure leakage.

Unit : mm

# KP47 SERIES

## Economical Pressure Sensor

### Features

- 3-color digital LCD display
- Main / Sub-Display, 4 digits 7 segment LCD display
- Programmable pressure unit :  
kPa、MPa、kgf/cm<sup>2</sup>、bar、psi、inHg、mmHg
- Dual LCD display allows setting value to be displayed
- Key lock indicator
- Power-save mode
- Fine adjustment mode

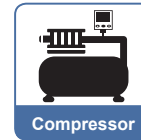
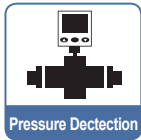
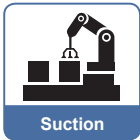

### Features Highlight

#### 1 Quick Installation

- Save installation time
- Easy removal

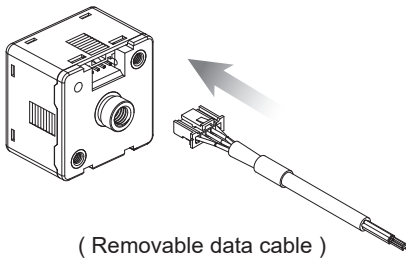

#### 2 Compact design

- Compared with similar products, approx. 35 % shorter

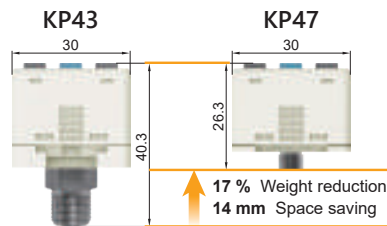

#### 3 Setting Value Easy Indication

- User can easily observe the setting value from sub-display



#### 4 2-Color Main Display

- User programmable color mode, for different setting conditions



	5.0k	5.0k	6.0k	7.6k
ON	Green	Red	Green	Red
OFF	Red	Green	Green	Red

#### 5 OPS Quick Setting

- Sub-display allows changing the parameter directly, reduce setting step by 3/4

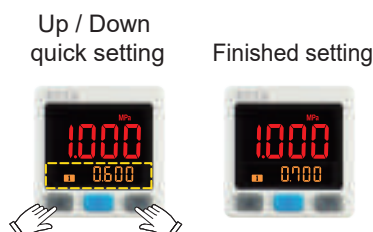

#### 6 Easy Unit Identification

- Conversion unit is on display and easy to read



## Specifications

MODEL	KP47C (Compound)	KP47V (Vacuum)	KP47P (Positive)
<b>Rated Pressure Range</b>	-100.0 ~ 100.0 kPa	0.0 ~ -101.3 kPa	-0.100 ~ 1.000 MPa
<b>Set Pressure Range</b>	-103.0 ~ 103.0 kPa	10.0 ~ -103.0 kPa	-0.103 ~ 1.030 MPa
<b>Withstand Pressure</b>	500 kPa		1.5 MPa
<b>Fluid</b>	Filtered air, Non-corrosive / Non-flammable gas		
<b>Set Pressure Resolution</b>	kPa	0.1	-
	MPa	-	0.001
	kgf / cm <sup>2</sup>	0.001	0.01
	bar	0.001	0.01
	psi	0.01	0.1
	inHg	0.1	-
	mmHg	1	-
<b>Power Supply Voltage</b>	12 to 24 V DC $\pm 10\%$ , Ripple ( P-P ) 10 % or less		
<b>Current Consumption</b>	$\leq 30$ mA ( With no load )		
<b>Switch Output</b>	NPN : open collector outputs Max. Load Current : 80 mA Max. Supply Voltage : 30 V DC Residual Voltage : $\leq 1$ V	PNP : open collector outputs Max. Load Current : 80 mA Max. Supply Voltage : 24 V DC Residual Voltage : $\leq 1$ V	
<b>Repeatability ( Switch Output )</b>	$\pm 0.3\%$ F.S. $\pm 1$ digit		
<b>Hysteresis</b>	One Point Set Mode	Adjustable *1	
	Hysteresis Mode		
	Window Comparator Mode		
<b>Response Time</b>	$\leq 2.5$ ms ( chattering-proof function : 25 ms, 100 ms, 250 ms, 500 ms, 1000 ms and 1500 ms selectable )		
<b>Output Short Circuit Protection</b>	Yes		
<b>Display</b>	4 digital, 7 segment LCD display ( Red / Green / Orange ) ( Sampling rate : 5 times / sec. )		
<b>Indicator Accuracy</b>	$\pm 1\%$ F.S. $\pm 1$ digit ( ambient temperature : $25 \pm 3$ °C )		
<b>Switch on Indicator</b>	Orange indicator 1 : OUT1 & Orange indicator 2 : OUT2		
<b>Analog Output ( Voltage Output )</b>	Output Voltage : 1 to 5 V $\pm 2.5\%$ F.S. ( within rated pressure range ) Linearity : $\pm 1\%$ F.S. Output Impedance : about 1 k $\Omega$		Output Voltage : 0.6 to 5 V $\pm 2.5\%$ F.S. ( within rated pressure range ) Linearity : $\pm 1\%$ F.S. Output Impedance : about 1 k $\Omega$
	<b>Enclosure</b>	IP 40	
<b>Environment</b>	<b>Ambient temp. range</b>	Operation : 0 ~ 50 °C, Storage : -10 ~ 60 °C ( No condensation or freezing )	
	<b>Ambient humidity range</b>	Operation / Storage : 35 ~ 85 % RH ( No condensation )	
	<b>Withstand voltage</b>	1000 V AC in 1-min ( between case and lead wire )	
	<b>Insulation resistance</b>	50 M $\Omega$ ( at 500 V DC, between case and lead wire )	
	<b>Vibration</b>	Total amplitude 1.5 mm or 10 G, 10 Hz - 150 Hz - 10 Hz scan for 1 minute, two hours each direction of X, Y and Z	
	<b>Shock</b>	100 m/s <sup>2</sup> ( 10 G ), 3 times each in direction of X, Y and Z	
<b>Temperature characteristic</b>	$\pm 2\%$ F.S. of detected pressure ( 25 °C ) at temp. Range of 0 ~ 50 °C		
<b>Port size</b>	F1 : R1/8" ; F2 : NPT1/8" ; F3 : G1/8" ( BSPP ) ; M5 : M5 female thread		
<b>Lead wire</b>	Oil-resistance cable ( 0.15 mm <sup>2</sup> )		
<b>Weight</b>	Approx. 67 g ( with 2 meter lead wire )		

**NOTE :**

\*1 : Hysteresis value is adjustable within 1 ~ 8 digits for one point set mode and window comparator mode.

# KP47 SERIES

# Economical Pressure Sensor

## Panel Description

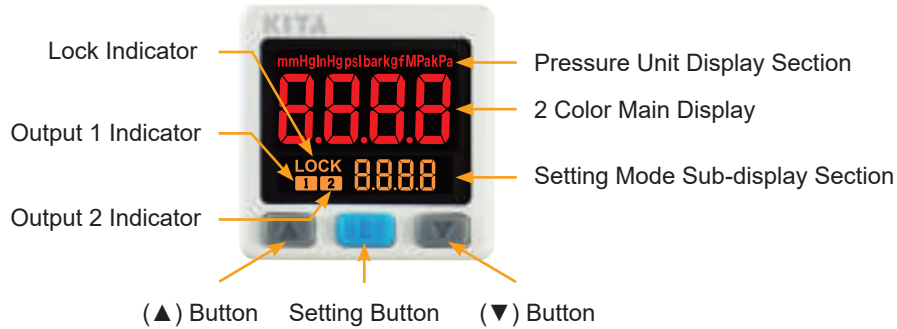

## Circuit Wiring Diagrams

### KP47□ - 01 - □

1NPN + Analog output ( 1 ~ 5 V ) ( 0.6 ~ 5 V only positive )

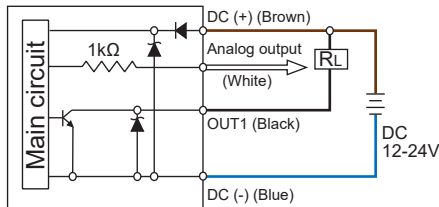

### KP47□ - 03 - □

1PNP + Analog output ( 1 ~ 5 V ) ( 0.6 ~ 5 V only positive )

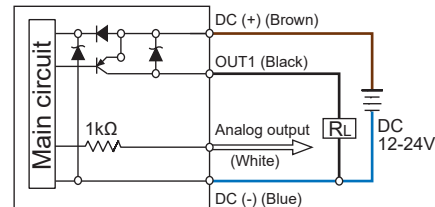

### KP47□ - 02 - □

2NPN + output

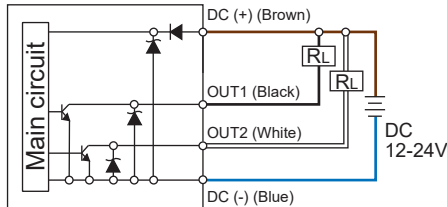

### KP47□ - 04 - □

2PNP + output

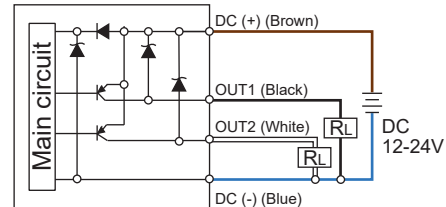

## Ordering Information

**K P 4 7 C - 0 1 - F 1**

### Pressure Range

C : Compound ( -103.0 ~ 103.0 kPa )  
 V : Vacuum ( 10.0 ~ -103.0 kPa )  
 P : Positive ( -0.103 ~ 1.030 MPa )

### Output Specifications

01 : 1 NPN output + Analog output ( 1 ~ 5 V )  
 02 : 2 NPN output  
 03 : 1 PNP output + Analog output ( 1 ~ 5 V )  
 04 : 2 PNP output

### Pressure Port

F1 : R1/8", M5  
 F2 : NPT1/8", #10-32UNF  
 F3 : G1/8" ( BSPP ), M5  
 M5 : M5 female thread

### Optional Parts

BT-22 : Mounting bracket  
 BT-23 : Mounting bracket  
 PA-C : Panel adapter  
 PA-D : Panel adapter + Front protective lid

### Optional Parts

■ Mounting Bracket : BT-22 / BT-23

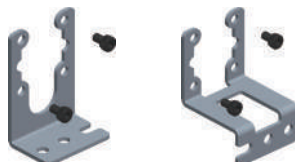

■ Panel Adapter : PA-C



■ Panel Adapter + Front Protective Lid : PA-D





# KP50E SERIES

Pneumatic · Hydraulic Pressure Sensor ( Multi-Medium )

## Features

- Corrosive fluid or gas available ( in the pipeline )
- Sensor parts & Fitting parts : Stainless steel 316L
- 2-color digital LCD display
- Copy function
- Programmable pressure unit :  
kPa 、 MPa 、 kgf / cm<sup>2</sup> 、 bar 、 psi 、 inHg
- IP65 enclosure

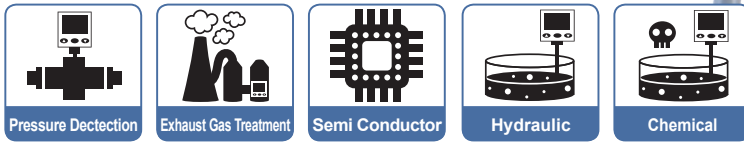

## Features Highlight

### 1 Quick Installation

- Save installation time
- Easy removal

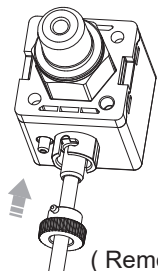

( Removable data cable )

### 2 Copy Setting

- Avoid setting errors
- Reduce setting time



( Original Parameter )

( Copied )

### 3 Easy Unit Identification

- Conversion unit is on display and easy to read



### 4 Applicable for Corrosive Fluid or Gas

- Sensor parts & Fitting parts are SUS 316L, applicable for corrosive fluid or gas equipment

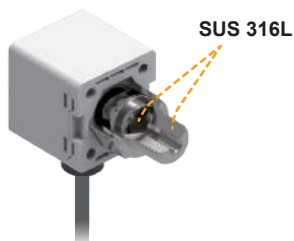

### 5 2-Color Display

- User programmable color mode, for different setting conditions



	500	500	600	red
ON	Green	Red	Green	Red
OFF	Red	Green	Green	Red

### 6 IP65 Compliance



## Specifications

MODEL		KP50EC (Compound)	KP50EV (Vacuum)	KP50EP (Positive)	KP50EH (High)
<b>Rated Pressure Range</b>		-100.0 ~ 100.0 kPa	0.0 ~ -101.3 kPa	0.000 ~ 1.000 MPa	0.000 ~ 2.00 MPa
<b>Set Pressure Range</b>		-101.0 ~ 101.0 kPa	10.0 ~ -101.3 kPa	-0.100 ~ 1.000 MPa	-0.100 ~ 2.00 MPa
<b>Withstand Pressure</b>		300 kPa		3 MPa	
<b>Fluid</b>		Fluids do not corrode stainless steel 316L			
<b>Sealed Liquid</b>		Silicon oil			
<b>Set Pressure Resolution</b>	kPa	0.1	-	-	-
	MPa	-	-	0.001	0.001 ( ~19.99 ) 0.01 ( 2.00~ )
	kgf / cm <sup>2</sup>	0.001	-	0.01	0.01 ( ~19.99 ) 0.1 ( 20.0~ )
	bar	0.001	-	0.01	0.01 ( ~19.99 ) 0.1 ( 20.0~ )
	psi	0.01	-	0.1	0.1 ( ~199.9 ) 1 ( 200~ )
	inHg	0.1	-	-	-
<b>Power Supply Voltage</b>		12 to 24 V DC $\pm 10\%$ , Ripple ( P-P ) 10 % or less			
<b>Current Consumption</b>		$\leq 40$ mA ( With no load )			
<b>Switch Output</b>		2NPN : open collector 2 outputs Max. Load Current : 125 mA Max. Supply Voltage : 30 V DC Residual Voltage : $\leq 1.5$ V		2PNP : open collector 2 outputs Max. Load Current : 125 mA Max. Supply Voltage : 24 V DC Residual Voltage : $\leq 1.5$ V	
<b>Repeatability ( Switch Output )</b>		$\pm 0.3\%$ F.S. $\pm 1$ digit			
<b>Hysteresis</b>	<b>One point set mode</b>	Adjustable *1			
	<b>Hysteresis mode</b>				
	<b>Window comparator mode</b>				
<b>Response Time</b>		$\leq 2.5$ ms ( chattering-proof function : 25 ms, 100 ms, 250 ms, 500 ms, 1000 ms and 1500 ms selectable )			
<b>Output Short Circuit Protection</b>		Yes			
<b>Display</b>		3 ½ digital, 7 segment LCD display ( Red / Green / Orange ) ( Sampling rate : 5 times / sec. )			
<b>Indicator Accuracy</b>		$\pm 2\%$ F.S. $\pm 1$ digit ( ambient temperature : 25 $\pm 3$ °C )			
<b>Switch on Indicator</b>		Orange indicator 1 : OUT1 & Orange indicator 2 : OUT2			
<b>Analog Output ( Voltage Output ) *2</b>		Output Voltage : 1 to 5 V $\pm 2.5\%$ F.S. ( within rated pressure range ) Linearity : $\pm 1\%$ F.S. Output Impedance : about 1 k $\Omega$			
<b>Analog Output ( Current Output ) *3</b>		Output Current : 4 to 20 mA $\pm 2.5\%$ F.S. ( within rated pressure range ) Linearity : $\pm 1\%$ F.S. Max. Load Impedance : 250 $\Omega$ at power supply of 12 V , 600 $\Omega$ at power supply of 24 V Min. Load Impedance : 50 $\Omega$			
<b>Environment</b>	<b>Enclosure</b>	IP 65 *5			
	<b>Ambient Temp. Range</b>	Operation : 0 ~ 50 °C, Storage : -10 ~ 60 °C ( No condensation or freezing )			
	<b>Ambient Humidity Range</b>	Operation / Storage : 35 ~ 85 % RH ( No condensation )			
	<b>Withstand Voltage</b>	250 V AC in 1-min ( between case and lead wire )			
	<b>Insulation Resistance</b>	50 M $\Omega$ ( at 500 V DC, between case and lead wire )			
	<b>Vibration</b>	Total amplitude 1.5 mm or 10 G, 10 Hz - 55 Hz - 10 Hz scan for 1 minute, two hours each direction of X, Y and Z			
	<b>Shock</b>	100 m/s <sup>2</sup> ( 10 G ), 3 times each in direction of X, Y and Z			
<b>Temperature Characteristic</b>		$\pm 3\%$ F.S. of detected pressure ( 25 °C ) at temp. Range of 0 ~ 50 °C			
<b>Port Size *4</b>		F1 : R1/4", M5 ; F2 : NPT1/4", #10-32 UNF ; F3 : G1/4" ( BSPP ), M5 ; F1C : Rc1/8"			
<b>Lead Wire</b>		Oil-resistance cable ( 0.15 mm <sup>2</sup> )			
<b>Weight ( With 2 Meter Lead Wire )</b>		Approx. 110 g ( Rear ported ), Approx. 150 g ( Bottom ported )			

### NOTE :

- \*1 : Hysteresis value is adjustable within 1 ~ 8 digits for one point set mode and window comparator mode.
- \*2 : If analog voltage output is selected, the analog current output cannot be selected at the same time.
- \*3 : If analog current output is selected, the analog voltage output cannot be selected at the same time.
- \*4 : G port O-Ring material is NBR. if any special request, please contact KITA.
- \*5 : Air tube must be installed to maintain IP65.

# KP50E SERIES

## Pneumatic · Hydraulic Pressure Sensor ( Multi-Medium )

### Panel Description



### Installation Precautions

- When mounting, always use the wrench on the metallic area near the pressure port. Never apply a wrench to the plastic body, it will damage the sensor.
- Over tightening may cause damages to the port thread, mounting bracket and pressure sensor. Under tightening may result loosen or leakage.
- Apply pressure and power after installation and make necessary adjustments and inspect any possible signs of leakage to ensure proper installation.

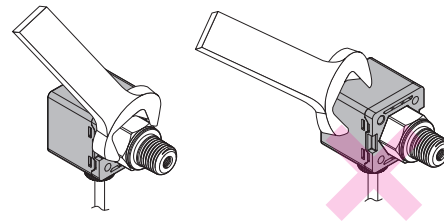

### Circuit Wiring Diagrams

**KP50E□ - 010 - □**  
2NPN + Analog Output ( 1 ~ 5 V )

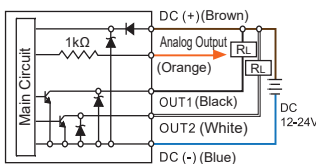

**KP50E□ - 011 - □**  
2NPN + Analog Output ( 4 ~ 20 mA )

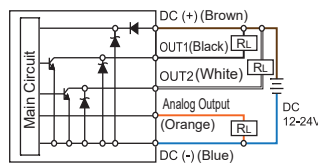

**KP50E□ - 02 - □**  
2NPN + Copy Function

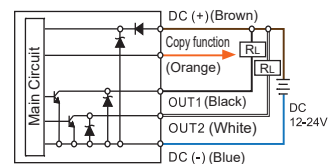

**KP50E□ - 030 - □**  
2PNP + Analog Output ( 1 ~ 5 V )

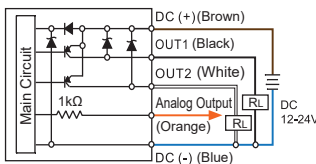

**KP50E□ - 031 - □**  
2PNP + Analog Output ( 4 ~ 20 mA )

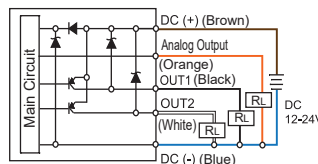

**KP50E□ - 04 - □**  
2PNP + Copy Function

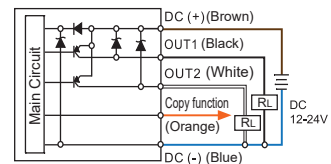

### Ordering Information

**K P 5 0 E H - 0 1 0 - F 1 □**

#### Pressure Range

H : High ( -0.100 ~ 2.00 MPa )  
C : Compound ( -101.0 ~ 101.0 kPa )  
V : Vacuum ( 10.0 ~ -101.3 kPa )  
P : Positive ( -0.100 ~ 1.000 MPa )

#### Output Specifications

010 : 2 NPN Output & Analog Output ( 1 ~ 5 V )  
011 : 2 NPN Output & Analog Output ( 4 ~ 20 mA )  
02 : 2 NPN Output & Copy Function  
030 : 2 PNP Output & Analog Output ( 1 ~ 5 V )  
031 : 2 PNP Output & Analog Output ( 4 ~ 20 mA )  
04 : 2 PNP Output & Copy Function

#### Pressure Port

F1 : R1/4", M5  
F2 : NPT1/4", #10-32UNF  
F3 : G1/4" ( BSPP ), M5  
F1C : Rc1/8" ( only with rear ported )

#### Piping Direction

Blank : Rear ported  
L : Bottom ported

#### Optional Parts

BT-10 : Mounting bracket  
BT-11 : Mounting bracket  
PA-E : Panel adapter  
PA-F : Panel adapter + Front protective lid  
I-0360 : Snubber ( for Pressure Port F1 & F3 )  
I-0379 : Snubber ( for Pressure Port F2 )  
\* KP50EP & KP50EH suggested to select a snubber

#### Optional Parts

- Mounting Bracket : BT-10 / BT-11
- Panel Adapter : PA-E
- Panel Adapter + Front Protective Lid : PA-F
- Snubber

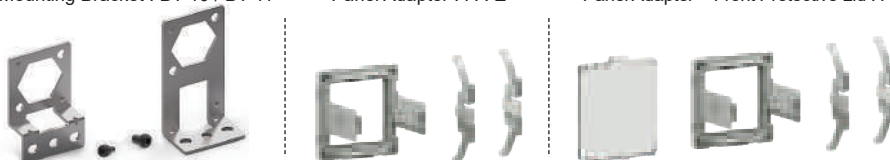

I-0360 : for Pressure Port F1 & F3  
I-0379 : for Pressure Port F2

## Removable Snubber Installed

- Pressure port equipped with snubber can avoid damage caused by sudden pressure surge of water or oil, improve product durability.

\* When snubber is clogged with contaminants, please use a flat head screwdriver to remove the snubber, clean and reinstall.  
 \* A snubber is not applied to F1C port.

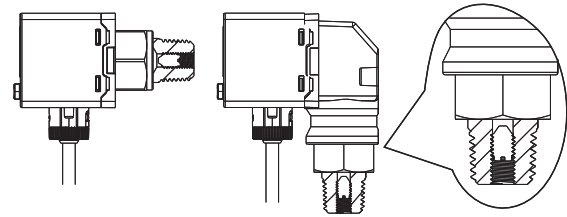

## Dimensions

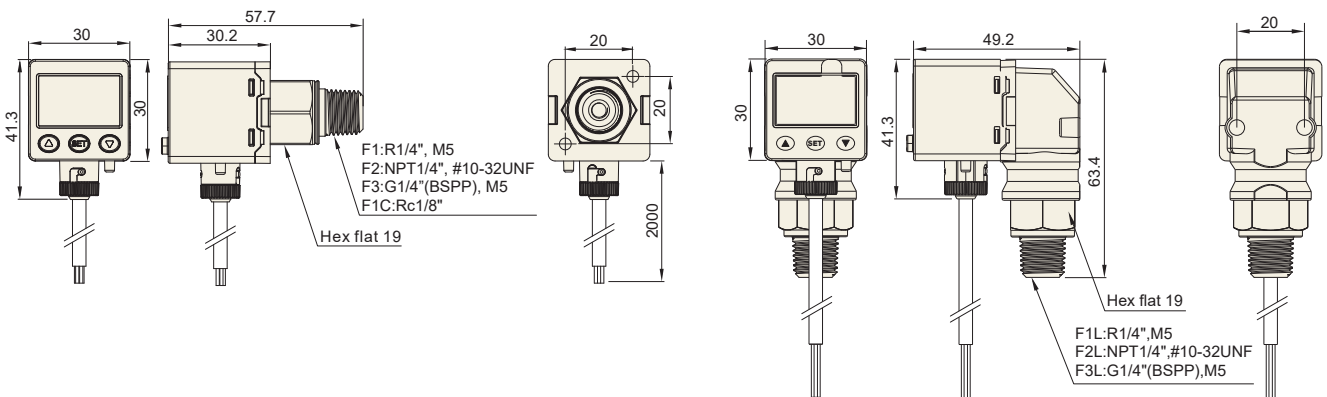

## Optional Parts Dimensions

### 1 Mounting Bracket

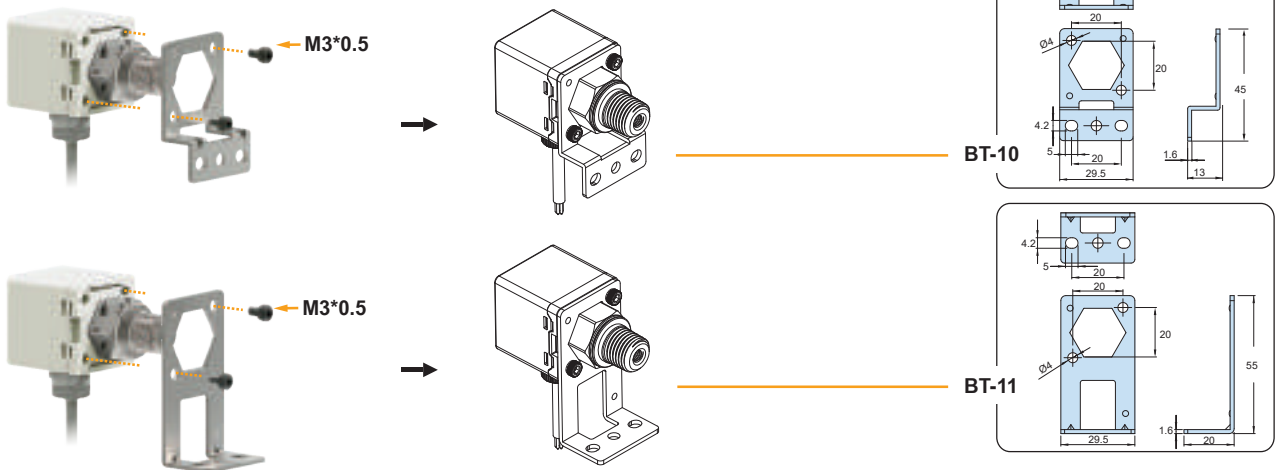

### 2 Panel Mount Adapter + Front Protective Lid

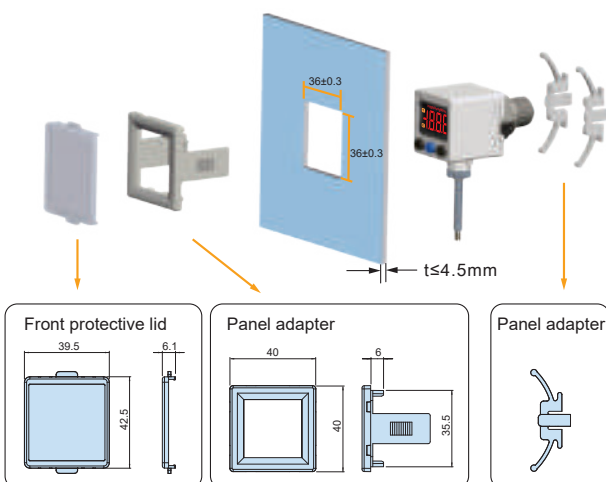

### 3 IP65 Protector

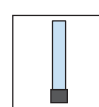
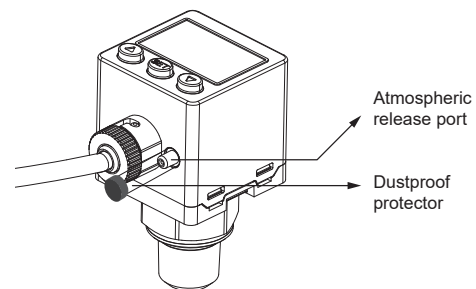

**Caution:**  
 This device must be installed to maintain IP 65 ( Dust and splash proof ) enclosure rating.

Unit : mm

# KP52 SERIES

Pneumatic · Hydraulic High Pressure Sensor (Multi-Medium)

## Features

- Sensor parts & Fitting parts : Stainless steel 316L
- 2-color digital LCD display
- Copy function
- Programmable pressure unit : MPa · kgf / cm<sup>2</sup> · bar · psi
- IP65 enclosure

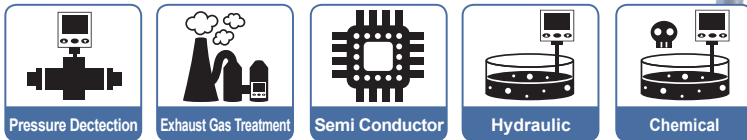

## Features Highlight

### 1 Quick Installation

- Save installation time
- Easy removal

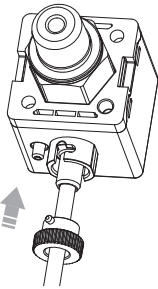

( Removable data cable )

### 2 Copy Setting

- Avoid setting errors
- Reduce setting time



( Original Parameter )

( Copied )

### 3 Easy Unit Identification

- Conversion unit is on display and easy to read



### 4 Applicable for Corrosive Fluid or Gas

- Sensor parts & Fitting parts are SUS 316L, applicable for corrosive fluid or gas equipment

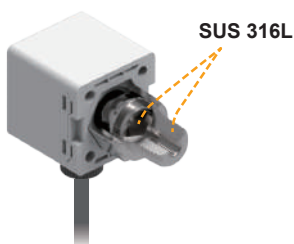

### 5 2-Color Display

- User programmable color mode, for different setting conditions



	SoL	SoR	LyRn	rEd
ON	Green	Red	Green	Red
OFF	Red	Green	Green	Red

### 6 IP65 Compliance



## Specifications

MODEL	KP52H07	KP52H10	KP52H25	KP52H40
<b>Rated Pressure Range</b>	0 ~ 7.00 MPa	0 ~ 10.00 MPa	0 ~ 25.0 MPa	0 ~ 40.0 MPa
<b>Set Pressure Range</b>	0 ~ 7.00 MPa	0 ~ 10.00 MPa	0 ~ 25.0 MPa	0 ~ 40.0 MPa
<b>Withstand Pressure</b>	14 MPa	20 MPa	50 MPa	80 MPa
<b>Fluid</b>	Fluids do not corrode stainless steel 316L, fluororubber (FKM)			
<b>Sealed Liquid</b>	Silicon oil			
<b>Set Pressure Resolution</b>	MPa	0.01	0.1	
	kgf / cm <sup>2</sup>	0.1	1	
	bar	0.1	1	
	psi	1	1 *5	
<b>Power Supply Voltage</b>	12 to 24 V DC $\pm 10\%$ , Ripple ( P-P ) 10 % or less			
<b>Current Consumption</b>	$\leq 40$ mA ( With no load )			
<b>Switch Output</b>	2NPN : open collector 2 outputs Max. load current : 125 mA Max. supply voltage : 30 V DC Residual voltage : $\leq 1.5$ V		2PNP : open collector 2 outputs Max. load current : 125 mA Max. supply voltage : 24 V DC Residual voltage : $\leq 1.5$ V	
<b>Repeatability ( Switch Output )</b>	$\pm 0.3\%$ F.S. $\pm 1$ digit			
<b>Hysteresis</b>	<b>One Point Set Mode</b>	Adjustable *1		
	<b>Hysteresis Mode</b>			
	<b>Window Comparator Mode</b>			
<b>Response Time</b>	$\leq 2.5$ ms ( chattering-proof function : 25 ms, 100 ms, 250 ms, 500 ms, 1000 ms and 1500 ms selectable )			
<b>Output Short Circuit Protection</b>	Yes			
<b>Display</b>	3 ½ digital, 7 segment LCD display ( Red / Green / Orange ) ( Sampling rate : 5 times / sec. )			
<b>Indicator Accuracy</b>	$\pm 2\%$ F.S. $\pm 1$ digit ( ambient temperature : 25 $\pm 3$ °C )			
<b>Switch on Indicator</b>	Orange indicator 1 : OUT1 & Orange indicator 2 : OUT2			
<b>Analog Output ( Voltage Output ) *2</b>	<b>Output Voltage</b>	1 to 5 V $\pm 2.5\%$ F.S. ( within rated pressure range )		
	<b>Output impedance</b>	about 1 k $\Omega$		
	<b>Linearity</b>	$\pm 1\%$ F.S.		
<b>Analog Output ( Current Output ) *3</b>	<b>Output Current</b>	4 to 20 mA $\pm 2.5\%$ F.S. ( within rated pressure range )		
	<b>Max.Load impedance</b>	250 $\Omega$ at power supply of 12 V , 600 $\Omega$ at power supply of 24 V		
	<b>Min.Load impedance</b>	50 $\Omega$		
	<b>Linearity</b>	$\pm 1\%$ F.S.		
<b>Environment</b>	<b>Enclosure</b>	IP 65 *6		
	<b>Ambient Temp. Range</b>	Operation : 0 ~ 50 °C, Storage : -10 ~ 60 °C ( No condensation or freezing )		
	<b>Ambient Humidity Range</b>	Operation / Storage : 35 ~ 85 % RH ( No condensation )		
	<b>Withstand Voltage</b>	250 V AC in 1-min ( between case and lead wire )		
	<b>Insulation Resistance</b>	50 M $\Omega$ ( at 500 V DC, between case and lead wire )		
	<b>Vibration</b>	Total amplitude 1.5 mm or 10 G, 10 Hz - 55 Hz - 10 Hz scan for 1 minute, two hours each direction of X, Y and Z		
	<b>Shock</b>	100 m/s <sup>2</sup> ( 10 G ) , 3 times each in direction of X, Y and Z		
<b>Temperature Characteristic</b>	$\pm 3\%$ F.S. of detected pressure ( 25 °C ) at temp. Range of 0 ~ 50 °C			
<b>Port Size *4</b>	F1 : R1/4", M5 ; F2 : NPT1/4", #10-32 UNF ; F3 : G1/4" ( BSPP ) , M5			
<b>Lead Wire</b>	Oil-resistance cable ( 0.15 mm <sup>2</sup> )			
<b>Weight ( With 2 Meter Lead Wire )</b>	Approx. 110 g ( Rear ported ) ; Approx. 145 g ( Bottom ported )			

### NOTE :

\*1 : Hysteresis value is adjustable within 1 ~ 8 digits for one point set mode and window comparator mode.

\*2 : If analog voltage output is selected, the analog current output cannot be selected at the same time.

\*3 : If analog current output is selected, the analog voltage output cannot be selected at the same time.

\*4 : G port O-Ring material is NBR. if any special request, please contact KITA.

\*5 : If set pressure unit is psi, the value requires to ten multiply by display value.

\*6 : Air tube must be installed to maintain IP65.

# KP52 SERIES

Pneumatic · Hydraulic High Pressure Sensor (Multi-Medium)

## Panel Description



## Installation Precautions

- When mounting, always use the wrench on the metallic area near the pressure port. Never apply a wrench to the plastic body, it will damage the sensor.
- Over tightening may cause damages to the port thread, mounting bracket and pressure sensor. Under tightening may result loosen or leakage.
- Apply pressure and power after installation and make necessary adjustments and inspect any possible signs of leakage to ensure proper installation.

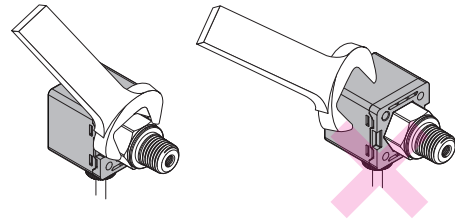

## Circuit Wiring Diagrams

**KP52H□ - 010 - □**  
2 NPN + Analog Output ( 1 ~ 5 V )

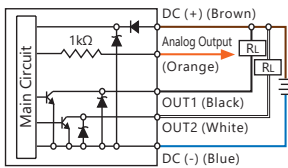

**KP52H□ - 011 - □**  
2 NPN + Analog Output ( 4 ~ 20 mA )

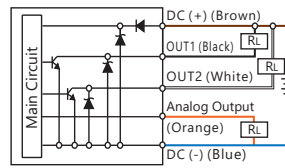

**KP52H□ - 02 - □**  
2 NPN + Copy Function

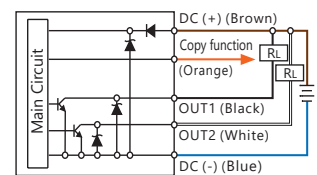

**KP52H□ - 030 - □**  
2 PNP + Analog Output ( 1 ~ 5 V )

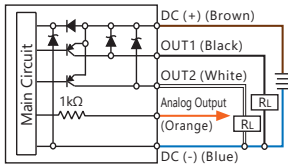

**KP52H□ - 031 - □**  
2 PNP + Analog Output ( 4 ~ 20 mA )

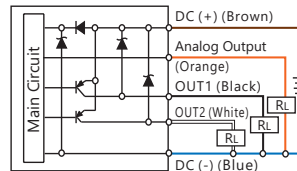

**KP52H□ - 04 - □**  
2 PNP + Copy Function

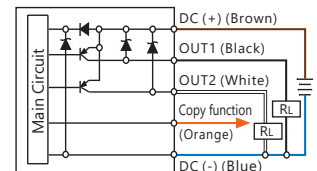

## Ordering Information

K P 5 2 H  - 0 1 0 - F 1

### Pressure Range

- 07 ( 0 ~ 7.00 MPa )
- 10 ( 0 ~ 10.00 MPa )
- 25 ( 0 ~ 25.0 MPa )
- 40 ( 0 ~ 40.0 MPa )

### Output Specifications

- 010 : 2 NPN Output & Analog Output ( 1 ~ 5 V )
- 011 : 2 NPN Output & Analog Output ( 4 ~ 20 mA )
- 02 : 2 NPN Output & Copy Function
- 030 : 2 PNP Output & Analog Output ( 1 ~ 5 V )
- 031 : 2 PNP Output & Analog Output ( 4 ~ 20 mA )
- 04 : 2 PNP Output & Copy Function

### Pressure Port

- F1 : R1/4", M5
- F2 : NPT1/4", #10-32UNF
- F3 : G1/4" ( BSPP ) , M5

### Piping Direction

- Blank : Rear ported
- L : Bottom ported

### Optional Parts

- BT-10 : Mounting bracket
- BT-11 : Mounting bracket
- PA-E : Panel adapter
- PA-F : Panel adapter + Front protective lid
- I-0360 : Snubber(for Pressure Port F1&F3)
- I-0379 : Snubber(for Pressure Port F2)
- \* KP52H are suggested to select a snubber.

### Optional Parts

- Mounting Bracket : BT-10 / BT-11
- Panel Adapter : PA-E
- Panel adapter + Front protective lid : PA-F
- Snubber

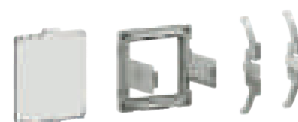

- I-0360 : for Pressure Port F1&F3
- I-0379 : for Pressure Port F2

## Removable Snubber Installed

- Pressure port equipped with snubber can avoid damage caused by sudden pressure surge of water or oil to improve product durability.

\* When snubber is clogged with contaminants, please use a flat head screwdriver to remove the snubber, clean and reinstall.

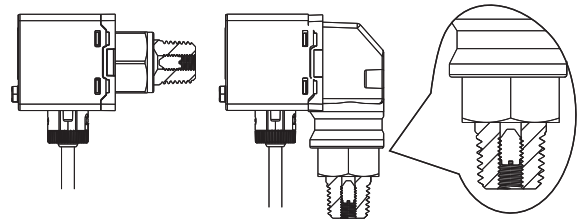

## Dimensions

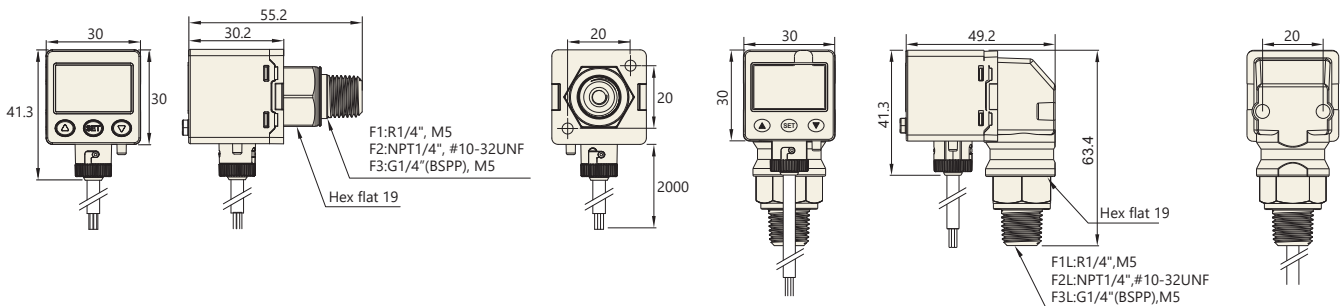

## Optional Parts Dimensions

### 1 Mounting Bracket

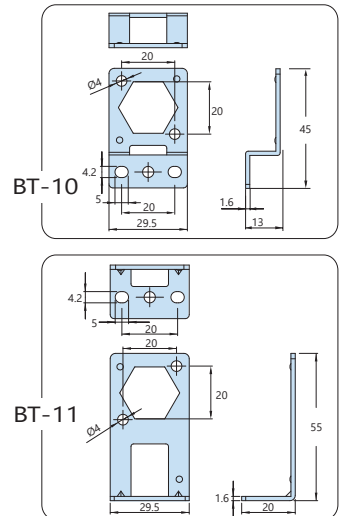
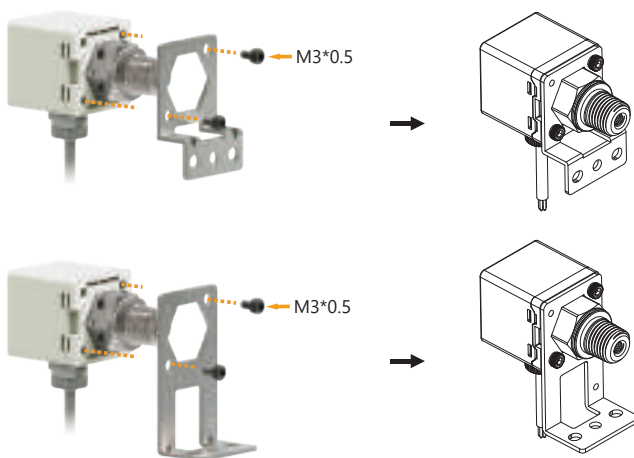

### 2 Panel Mount Adapter + Front Protective Lid

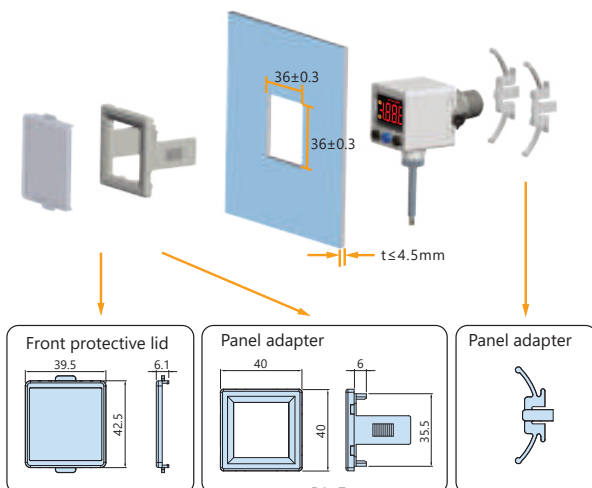

### 3 IP65 Protector

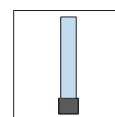
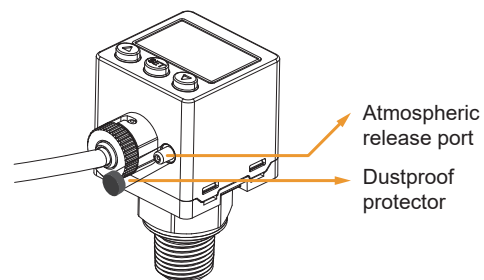

**Caution:**  
This device must be installed to maintain IP 65 (Dust and splash proof) enclosure rating.

Unit : mm

# KP60 SERIES

## Battery Pressure Gauge

### Features

- Digital pressure gauge with battery power
- Programmable pressure unit :  
kPa 、 MPa 、 kgf / cm<sup>2</sup> 、 bar 、 psi 、 mmHg
- Power save function
- Battery meter displayed on LCD
- Backlight type available
- IP65 enclosure

Patented

Battery Meter

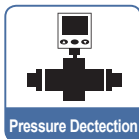

### Specifications

MODEL	KP60V (Vacuum)	KP60VL (Vacuum)	KP60P (Positive)	KP60PL (Positive)
Rated Pressure Range	0 ~ -101 kPa		0.000 ~ 1.000 MPa	
Display Pressure Range	10 ~ -101 kPa		-0.100 ~ 1.000 MPa	
Withstand Pressure	300 kPa		1.5 MPa	
Applicable Fluid	Filtered air, incombustible and non-corrosive gases			
Pressure Resolution	kPa	1	-	
	MPa	-	0.001	
	kgf / cm <sup>2</sup>	-	0.01	
	bar	0.01	0.01	
	psi	0.1	0.1	
mmHg	1	-		
Battery	CR 2032 lithium			
Back Light	No	Yes	No	Yes
Battery Life	3 years ( 5 times / day )	1 year ( 5 times / day )	3 years ( 5 times / day )	1 year ( 5 times / day )
Low-Power Indicator	Yes			
Battery Replaceable	Yes			
Turn-On Interval	Display turn off after 60 sec.			
Sampling Rate	2 Hz ( 2 times / sec. )			
Programmable Pressure Unit	psi, bar, mmHg, kPa		psi, bar, kgf / cm <sup>2</sup> , MPa	
Repeatability	±1 % F.S. ±1 digit		±0.2 % F.S. ±1 digit	
Display	3 ½ digital, 7 segment LCD display ( Black )			
Indicator Accuracy	±2 % F.S. ±1 digit ( ambient temperature : 25 ±3 °C )			
Environment	Enclosure	IP 65 *1		
	Ambient Temp. Range	Operation : 0 ~ 50 °C, storage : -10 ~ 60 °C ( No condensation or freezing )		
	Ambient Humidity Range	Operation / Storage : 35 ~ 85 % RH ( No condensation )		
	Vibration	Total amplitude 1.5 mm or 10 G, 10 Hz - 55 Hz - 10 Hz scan for 1 minute, two hours each direction of X, Y and Z		
Shock	100 m/s <sup>2</sup> ( 10 G ), 3 times each in direction of X, Y and Z			
Temperature Characteristic	±2 % F.S. of detected pressure ( 25 °C ) at temp. range of 0 ~ 50 °C			
Port Size	F1 : R1/8", M5 ; F2 : NPT1/8"NPT, #10-32 UNF ; F3 : G1/8"(BSPP), M5 ; F4 : R1/4", M5 ; F5 : NPT1/4", #10-32 UNF ; F6 : G1/4"(BSPP), M5			
Weight	Approx. 40 g			

NOTE :

\*1 : Air tube must be installed to maintain IP65.

## Ordering Information

**K P 6 0 P** - **F 1**

### Pressure Range

V : Vacuum ( 10 ~ -101 kPa )  
P : Positive ( -0.100 ~ 1.000 MPa )

### Back Light

Blank : Back light unavailable  
L : Back light available

### Optional Parts

BT-5 : Mounting bracket      PA-C : Panel adapter  
BT-6 : Mounting bracket      PA-D : Panel adapter + Front protective lid

### Optional Parts

■ Mounting Bracket : BT-5 / BT-6      ■ Panel Adapter : PA-C      ■ Panel adapter + Front protective lid : PA-D



## Panel Description

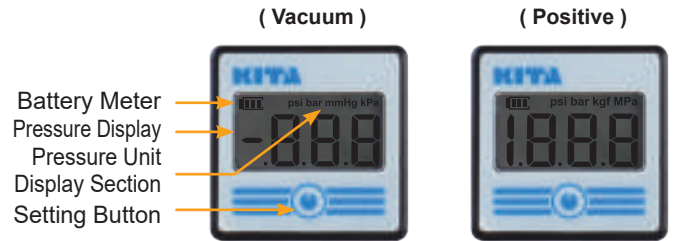

## Dimensions

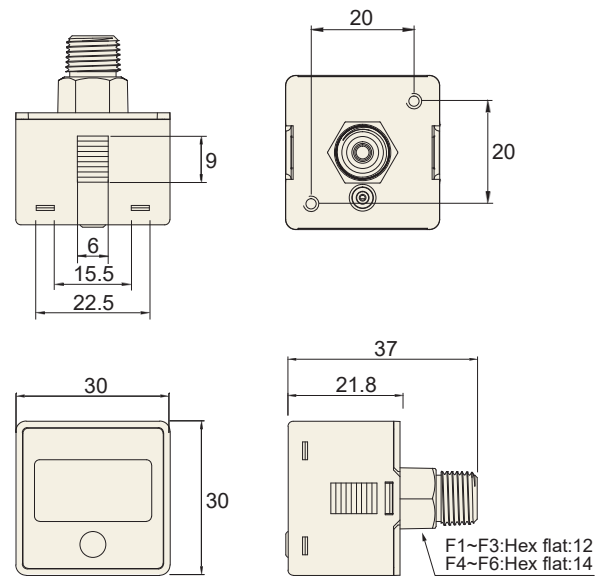

## Optional Parts Dimensions

### 1 Mounting Bracket

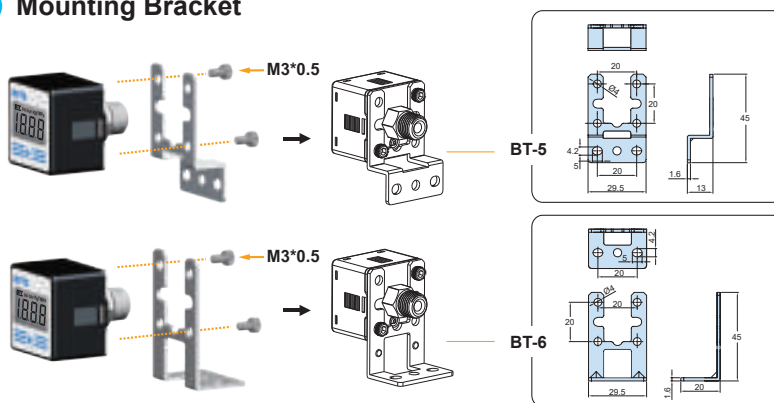

### 3 IP65 Protector

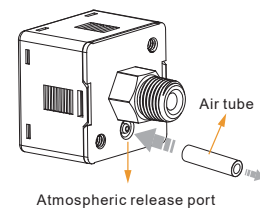

Caution :

1. To maintain IP65, please insert an air tube ( O.D.: 4 mm ) into atmospheric release port and pipe the other end away from dust / spattering liquid environment.

2. Use proper air tube dimension of O.D.: 4 mm, I.D.: 2.5 mm, and the length is depending on the user's environment.

### 2 Panel Mount Adapter + Front Protective Lid

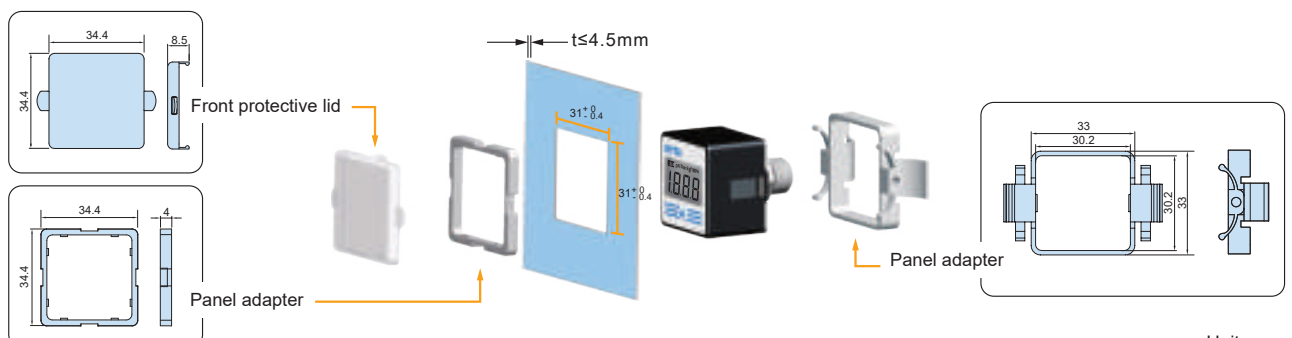

Unit : mm

# KP61

## SERIES

## Pressure Gauge

### Features

- Digital pressure gauge
- Setting pressure range :  
Vacuum ( 10 ~ -101 kPa )  
Positive ( -0.100 ~ 1.000 MPa )
- Programmable pressure unit :  
kPa 、 MPa 、 kgf / cm<sup>2</sup> 、 bar 、 psi
- IP65 enclosure

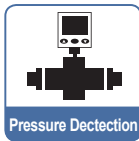

### Specifications

MODEL		KP61V (Vacuum)	KP61P (Positive)
Rated Pressure Range		0 ~ -101 kPa	0.000 ~ 1.000 MPa
Display Pressure Range		10 ~ -101 kPa	-0.100 ~ 1.000 MPa
Withstand Pressure		300 kPa	1.5 MPa
Applicable Fluid		Filtered air, incombustible and non-corrosive gases	
Pressure Resolution	kPa	1	-
	MPa	-	0.001
	kgf / cm <sup>2</sup>	0.01	0.01
	bar	0.01	0.01
	psi	0.1	0.1
Power Supply Voltage		12 to 28 V DC ±10 %, Ripple ( P-P ) 10 % or less	
Current Consumption		10 mA	
Sampling Rate		2 Hz ( 2 times / sec. )	
Repeatability		±1 % F.S. ±1 digit	±0.2 % F.S. ±1 digit
Display		3 ½ digital, 7 segment LCD display ( White )	
Indicator Accuracy		±2% F.S. ±1 digit ( ambient temperature : 25 ±3 °C )	
Environment	Enclosure	IP 65 *1	
	Ambient Temp. Range	Operation : 0 ~ 50 °C, storage : -10 ~ 60 °C ( No condensation or freezing )	
	Mbient Humidity Range	Operation / Storage : 35 ~ 85 % RH ( No condensation )	
	Withstand Voltage	1000 V AC in 1-min ( between case and lead wire )	
	Insulation Resistance	50 MΩ ( at 500 V DC, between case and lead wire )	
	Vibration	Total amplitude 1.5 mm or 10 G, 10 Hz - 55 Hz - 10 Hz scan for 1 minute, two hours each direction of X, Y and Z	
	Shock	100 m/s <sup>2</sup> ( 10 G ), 3 times each in direction of X, Y and Z	
Temperature Characteristic		±2 % F.S. of detected pressure ( 25 °C ) at temp. range of 0 ~ 50 °C	
Port Size		F1 : R1/8", M5 ; F2 : NPT1/8", #10-32 UNF ; F3 : G1/8" ( BSPP ), M5	
Lead Wire		Oil-resistance cable ( 0.15 mm <sup>2</sup> )	
Weight		Approx. 60 g ( with 2 meter lead wire ), Approx. 40 g ( with M8 4Pin male connector )	

NOTE :

\*1 : Air tube must be installed to maintain IP65.

## Panel Description

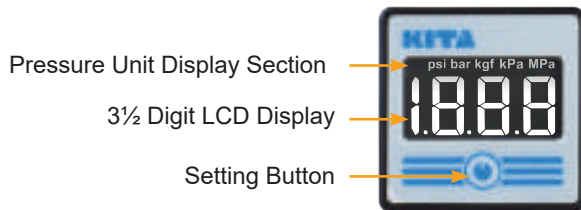

## Circuit Wiring Diagram

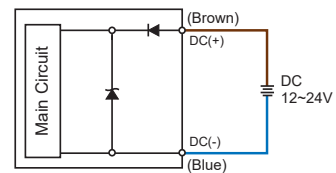

\* Pressure display only, no switch output function.

## Ordering Information

**K P 6 1 P - F 1 -**

### Pressure Range

V : Vacuum ( 10 ~ -101 kPa )  
P : Positive ( -0.100 ~ 1.000 MPa )

### Cable Length / Connector

Blank : With 2 meter cable  
QD : With M8 4Pin male connector

### Optional Parts

BT-5 : Mounting bracket  
BT-6 : Mounting bracket  
PA-C : Panel adapter  
PA-D : Panel adapter + Front protective lid

### Pressure Port

F1 : R1/8", M5  
F2 : NPT1/8", #10-32 UNF  
F3 : G1/8" ( BSPP ), M5

## Dimensions

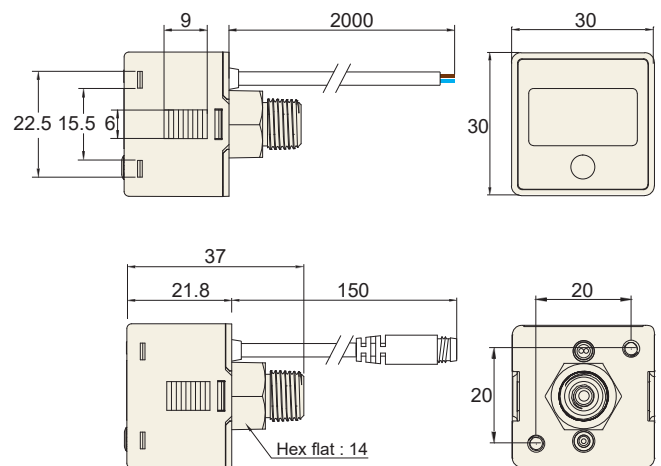

## Optional Parts Dimensions

### 1 Mounting Bracket

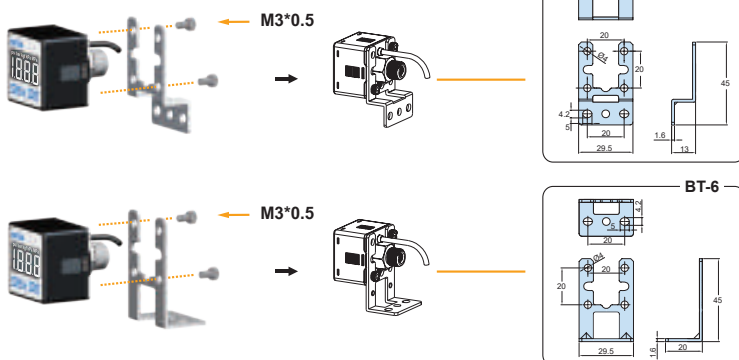

### 3 IP65 Protector

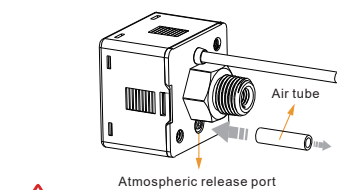

Caution :

- To maintain IP65, please insert an air tube ( O.D.: 4 mm ) into atmospheric release port and pipe the other end away from dust / spattering liquid environment.
- Use proper air tube dimension of O.D.: 4 mm, I.D.: 2.5 mm, and the length is depending on the user's environment.

### 2 Panel Mount Adapter + Front Protective Lid

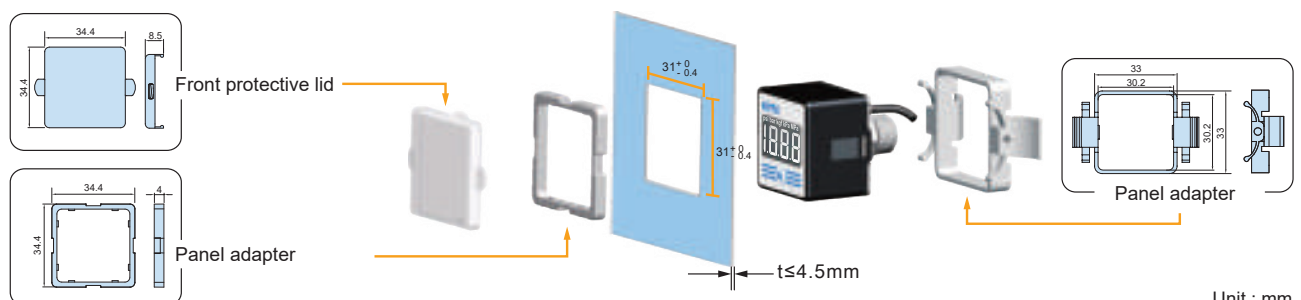

Unit : mm

# KP70 SERIES

# IOT Pressure Sensor

## Features

- Smart pressure sensor
- Remote control
- Real-time monitoring
- RS-485 Modbus RTU / ASCII
- 4 digits, 7 segment LCD display

RS485 MODBUS CONTROL

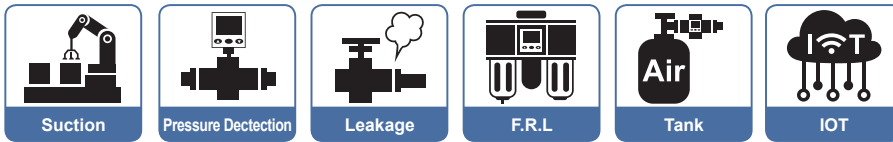

## Features Highlight

### 1 Station Setting Display

- Provide 0 ~ 255 station to set the sensor



ID number display

### 2 Modes Display

- Three modes show on the screen



### 3 Setting Value Easy Indication

- User can easily observe the setting value from sub-display

Main / Sub-Display

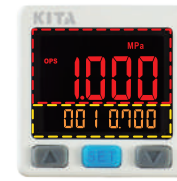

Main Display

Sub-Display

### 4 Easy Unit Identification

- Conversion unit is on display and easy to read



### 5 2-Color Main Display

- User programmable color mode, for different setting conditions



	50%	50%	Green	Red
ON	Green	Red	Green	Red
OFF	Red	Green	Green	Red

### 6 OPS Quick Setting

- Sub-display allows changing the parameter directly, reduce setting step by 3/4

Up / Down quick setting

Finished setting



## Specifications

MODEL	KP70C (Compound)	KP70V (Vacuum)	KP70P (Positive)
Rated Pressure Range	-100.0 ~ 100.0 kPa	0.0 ~ -101.3 kPa	0.000 ~ 1.000 MPa
Set Pressure Range	-101.0 ~ 101.0 kPa	10.0 ~ -101.3 kPa	-0.100 ~ 1.000 MPa
Withstand Pressure	500 kPa		1.5 MPa
Fluid	Filtered air, Non-corrosive / Non-flammable gas		
Set Pressure Resolution	kPa	0.1	-
	MPa	-	0.001
	kgf / cm <sup>2</sup>	0.001	0.01
	bar	0.001	0.01
	psi	0.01	0.1
	inHg	0.1	-
	mmHg	1	-
Power Supply Voltage	12 to 24 V DC $\pm 10\%$ , Ripple ( P-P ) 10 % or less		
Current Consumption	$\leq 40$ mA ( With no load )		
Switch Output	1NPN : open collector 1 output Max. Load Current : 125 mA Max. Supply Voltage : 30 V DC Residual Voltage : $\leq 1.5$ V	1PNP : open collector 1 output Max. Load Current : 125 mA Max. Supply Voltage : 24 V DC Residual Voltage : $\leq 1.5$ V	
Repeatability ( Switch Output )	$\pm 0.2\%$ F.S. $\pm 1$ digit		
Hysteresis	One Point Set Mode	Adjustable *1	
	Hysteresis Mode		
	Window Comparator Mode		
Response Time	$\leq 2.5$ ms ( chattering-proof function : 25 ms, 100 ms, 250 ms, 500 ms, 1000 ms, 1500 ms, 2000 ms and 5000 ms selectable )		
Output Short Circuit Protection	Yes		
Display	4 digital, 7 segment LCD display ( Red / Green / Orange ) ( Sampling rate : 0.2 , 0.5 , 1 seconds / time selectable )		
Indicator Accuracy	$\pm 2\%$ F.S. $\pm 1$ digit ( ambient temperature : $25 \pm 3$ °C )		
Switch on Indicator	Orange indicator 1 : OUT		
Environment	Enclosure	IP40	
	Ambient Temp. Range	Operation : 0 ~ 50 °C, Storage : -10 ~ 60 °C ( No condensation or freezing )	
	Ambient Humidity Range	Operation / Storage : 35 ~ 85 % RH ( No condensation )	
	Withstand Voltage	1000 V AC in 1-min ( between case and lead wire )	
	Insulation Resistance	50 M $\Omega$ ( at 500 V DC, between case and lead wire )	
	Vibration	Total amplitude 1.5 mm or 10 G, 10 Hz - 55 Hz - 10 Hz scan for 1 minute, two hours each direction of X, Y and Z	
Shock	100 m/s <sup>2</sup> ( 10 G ), 3 times each in direction of X, Y and Z		
Temperature Characteristic	$\pm 2.5\%$ F.S. of detected pressure ( 25 °C ) at temp. Range of 0 ~ 50 °C		
Communication Interface	RS-485		
Port Size	F1 : R1/8", M5 ; F2 : NPT1/8", #10-32 UNF ; F3 : G1/8" ( BSPP ), M5		
Lead Wire	Oil-resistance cable ( 0.15 mm <sup>2</sup> )		
Weight	Approx. 80 g ( with 2 meter lead wire )		

NOTE :

\*1 : Hysteresis value is adjustable within 1 ~ 8 digits for one point set mode and window comparator mode.

# KP70 SERIES

# IOT Pressure Sensor

## Panel Description

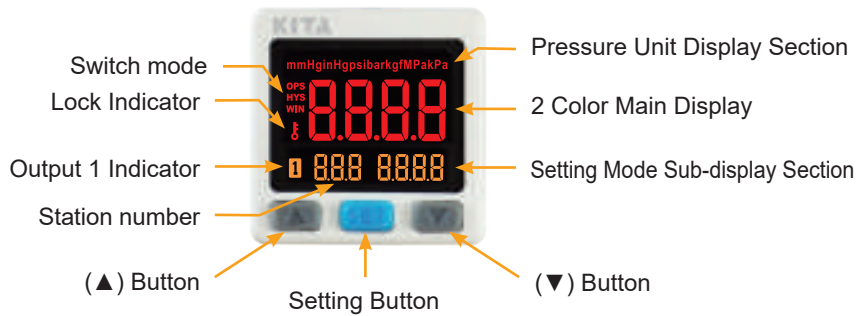

## Installation Precautions

- When mounting, always use the wrench on the metallic area near the pressure port. Never apply a wrench to the plastic body, it will damage the sensor.
- Over tightening may cause damages to the port thread, mounting bracket and pressure sensor. Under tightening may result loosen or leakage.
- Apply pressure and power after installation and make necessary adjustments and inspect any possible signs of leakage to ensure proper installation.

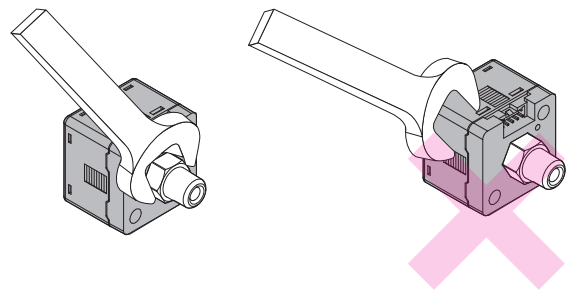

## Output Circuit Wiring Diagrams

KP70 □ - 02 - □

NPN output + RS485

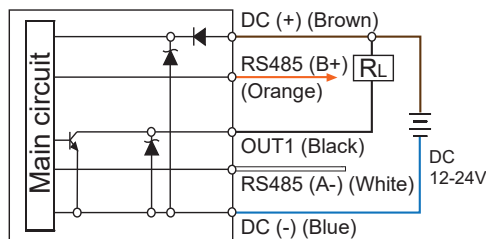

KP70 □ - 04 - □

PNP output + RS485

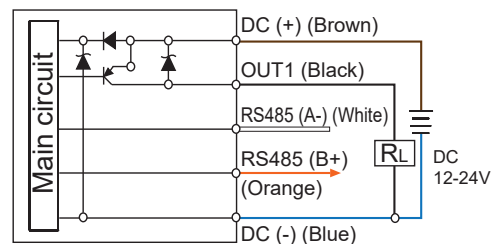

## Ordering Information

**K P 7 0 C - 0 2 - F 1**

### Pressure Range

C : Compound ( -101.0 ~ 101.0 kPa )  
 V : Vacuum ( 10.0 ~ -101.3 kPa )  
 P : Positive ( -0.100 ~ 1.000 MPa )

### Output Specifications

02 : 1 NPN output + RS485  
 04 : 1 PNP output + RS485

### Pressure Port

F1 : R 1/8", M5  
 F2 : NPT 1/8", #10-32UNF  
 F3 : G 1/8" ( BSPP ), M5

### Optional Parts

BT-12 : Mounting bracket  
 BT-13 : Mounting bracket  
 PA-C : Panel adapter  
 PA-D : Panel adapter + Front protective lid

### Optional Parts

- Mounting Bracket : BT-12 / BT-13



- Panel Adapter : PA-C



- Panel Adapter + Front Protective Lid : PA-D



## Dimensions

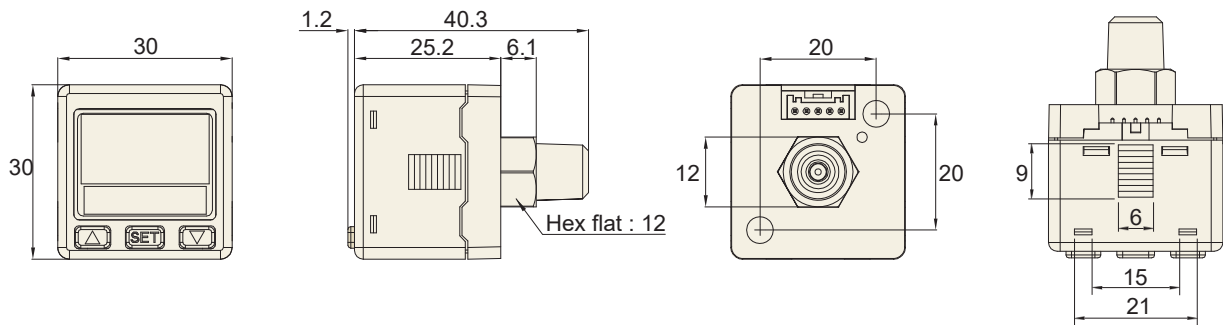

## Optional Parts Dimensions

### 1 Mounting Bracket

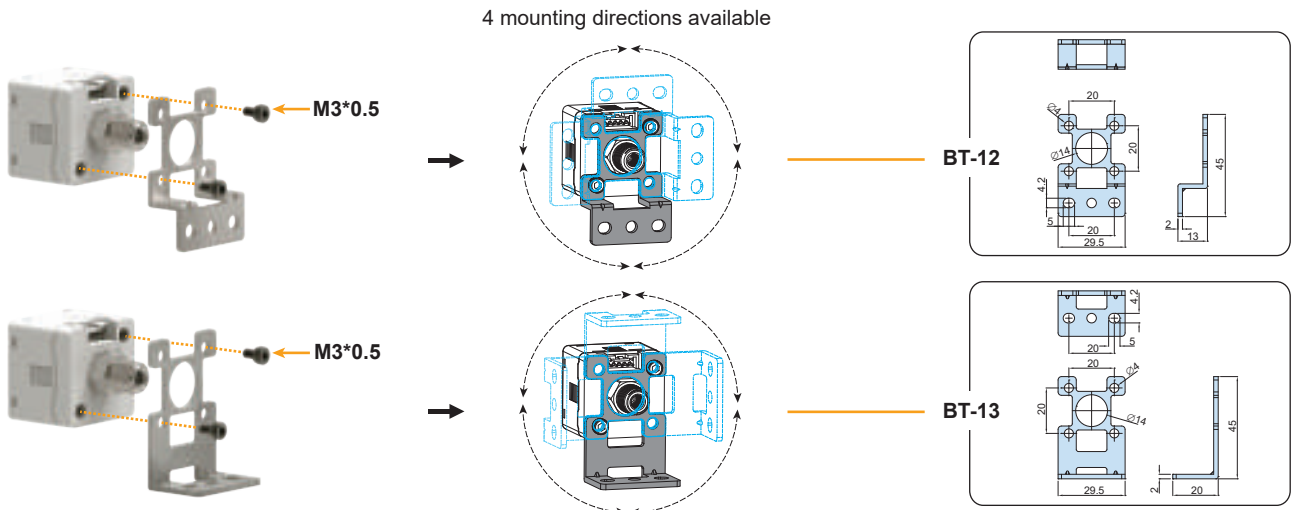

### 2 Panel Mount Adapter + Front Protective Lid

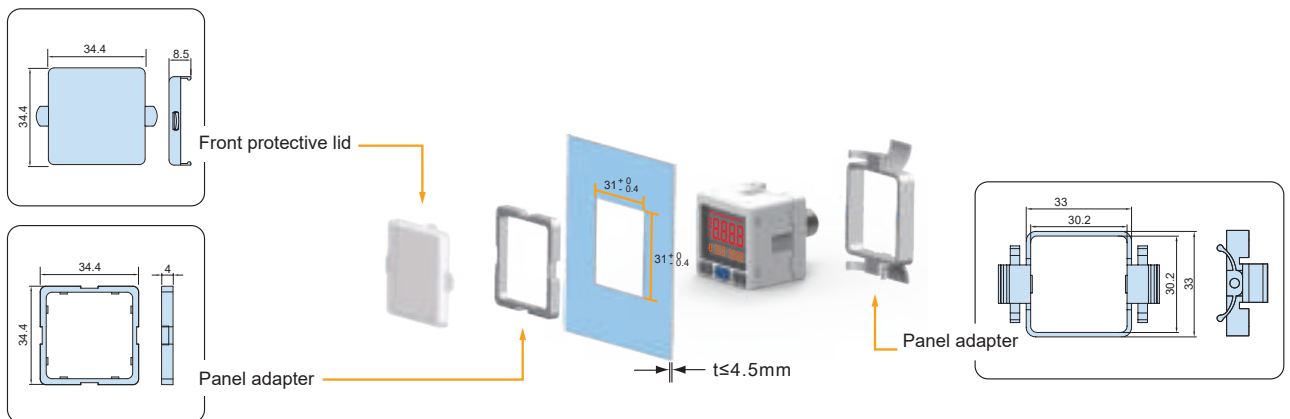

Unit : mm

# KP75 SERIES

IOT Pneumatic · Hydraulic High Pressure Sensor ( Multi-Medium )

## Features

- Corrosive fluid or gas available ( in the pipeline )
- Sensor parts & Fitting parts : Stainless steel 316L
- 2-color digital LCD display
- Remote control / Real-time monitoring
- RS-485 Modbus RTU / ASCII
- 3½ digit, 7 segment LCD display
- IP65 enclosure

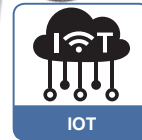
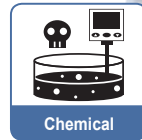
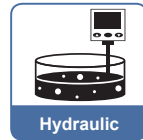
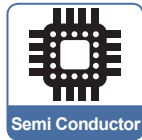

RS485 MODBUS CONTROL

## Features Highlight

### 1 Quick Installation

- Save installation time
- Easy removal

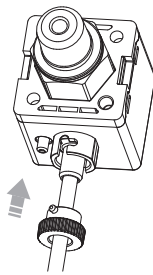

( Removable data cable )

### 2 Easy Unit Identification

- Conversion unit is on display and easy to read

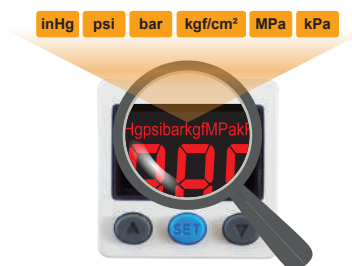

### 3 Applicable for Corrosive Fluid or Gas

- Sensor parts & Fitting parts are SUS 316L, applicable for corrosive fluid or gas equipment

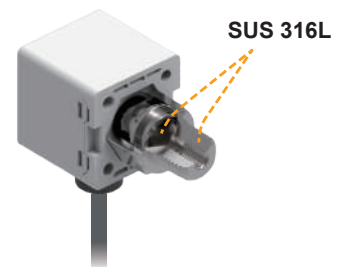

### 4 2-Color Display

- User programmable color mode, for different setting conditions



	5.00	5.00	0.00	0.00
ON	Green	Red	Green	Red
OFF	Red	Green	Green	Red

### 5 IP65 Compliance



## Specifications

MODEL	KP75C (Compound)	KP75P (Positive)	KP75H02 (High)	KP75H07 (High)	KP75H10 (High)	KP75H25 (High)	KP75H40 (High)	
<b>Rated Pressure Range</b>	-100.0 ~ 100.0 kPa	0.000 ~ 1.000 MPa	0.000 ~ 2.00 MPa	0.00 ~ 7.00 MPa	0.00 ~ 10.00 MPa	0.0 ~ 25.0 MPa	0.0 ~ 40.0 MPa	
<b>Set Pressure Range</b>	-101.0 ~ 101.0 kPa	-0.100 ~ 1.000 MPa	-0.100 ~ 2.00 MPa	0.00 ~ 7.00 MPa	0.00 ~ 10.00 MPa	0.0 ~ 25.0 MPa	0.0 ~ 40.0 MPa	
<b>Withstand Pressure</b>	300 kPa	3 MPa	3 MPa	14 MPa	20 MPa	50 MPa	80 MPa	
<b>Fluid</b>	Fluids do not corrode stainless steel 316L			Fluids do not corrode stainless steel 316L, fluororubber (FKM)				
<b>Sealed Liquid</b>	Silicon oil							
<b>Set Pressure Resolution</b>	kPa	0.1	-	-	-	-	-	
	MPa	-	0.001	0.001 (~ 1.999) 0.01 (2.00 ~)	0.01	0.01	0.1	0.1
	kgf / cm <sup>2</sup>	0.001	0.01	0.01 (~ 19.99) 0.1 (20.0 ~)	0.1	0.1	1	1
	bar	0.001	0.01	0.01 (~ 19.99) 0.1 (20.0 ~)	0.1	0.1	1	1
	psi	0.01	0.1	0.1 (~ 199.9) 1 (200 ~)	1	1	1 *1	1 *1
	inHg	0.1	-	-	-	-	-	-
<b>Power Supply Voltage</b>	12 to 24 V DC ±10 %, Ripple (P-P) 10 % or less							
<b>Current Consumption</b>	≤ 40 mA ( With no load )							
<b>Switch Output</b>	1NPN or 1PNP open collector Max. Load Current : 125 mA Max. Supply Voltage : 1 NPN 30 V DC, 1 PNP 24 V DC Residual Voltage : ≤ 1.5 V							
<b>Repeatability ( Switch Output )</b>	±0.3 % F.S. ±1 digit							
<b>Response Time</b>	≤ 2.5 ms ( chattering-proof function : 25 ms, 100 ms, 250 ms, 500 ms, 1000 ms and 1500 ms selections )							
<b>Output Short Circuit Protection</b>	Yes							
<b>Display</b>	3 ½ digital, 7 segment LCD display ( Red / Green / Orange ) ( Sampling rate : 5 times / sec. )							
<b>Indicator Accuracy</b>	±2 % F.S. ±1 digit ( ambient temperature : 25 ±3 °C )							
<b>Switch on Indicator</b>	Orange indicator 1 : OUT							
<b>Environment</b>	<b>Enclosure</b>	IP65 *2						
	<b>Ambient Temp. Range</b>	Operation : 0 ~ 50 °C, Storage : -10 ~ 60 °C ( No condensation or freezing )						
	<b>Ambient Humidity Range</b>	35 ~ 85 % RH ( No condensation )						
	<b>Withstand Voltage</b>	250 V AC in 1-min ( between case and lead wire )						
	<b>Insulation Resistance</b>	50 MΩ ( at 500 V DC, between case and lead wire )						
	<b>Vibration</b>	Total amplitude 1.5 mm or 10 G, 10 Hz - 55 Hz - 10 Hz scan for 1 minute, two hours each direction of X, Y and Z						
	<b>Shock</b>	100 m/s <sup>2</sup> ( 10 G ) , 3 times each in direction of X, Y and Z						
<b>Temperature Characteristic</b>	±3 % F.S. of detected pressure ( 25 °C ) at temp. Range of 0 ~ 50 °C							
<b>Communication Interface</b>	RS-485							
<b>Port Size *3</b>	F1 : R1/4", M5、F2 : NPT1/4", #10-32UNF、F3 : G1/4" ( BSPP ) , M5							
<b>Lead Wire</b>	Oil-resistance cable ( 0.15 mm <sup>2</sup> )							
<b>Weight</b>	Approx. 110 g ( Rear ported ) ; Approx. 150 g ( Bottom ported )							

**NOTE :**

\*1 : When using a unit psi, please multiply display value by 10.

\*2 : Air tube must be installed to maintain IP65.

\*3 : G port O-Ring material is NBR. if any special request, please contact KITA.

# KP75 SERIES

## IOT Pneumatic · Hydraulic High Pressure Sensor ( Multi-Medium )

### Panel Description



### Installation Precautions

- When mounting, always use the wrench on the metallic area near the pressure port. Never apply a wrench to the plastic body, it will damage the sensor.
- Over tightening may cause damages to the port thread, mounting bracket and pressure sensor. Under tightening may result loosen or leakage.
- Apply pressure and power after installation and make necessary adjustments and inspect any possible signs of leakage to ensure proper installation.

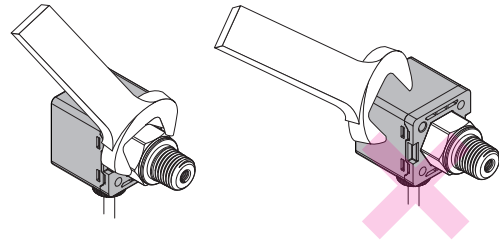

### Circuit Wiring Diagrams

**KP75□ - 02 - □**  
NPN output + RS485

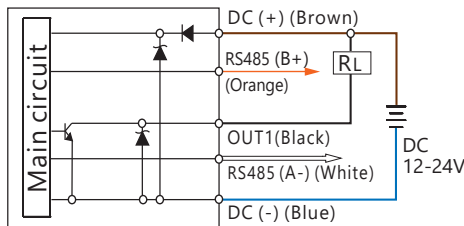

**KP75□ - 04 - □**  
PNP output + RS485

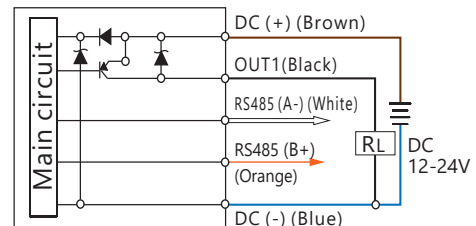

### Ordering Information

**K P 7 5 □ - 0 2 - F 1 □**

#### Pressure Range

- C : Compound ( -101.0 ~ 101.0 kPa )
- P : Positive ( -0.100 ~ 1.000 MPa )
- H02 : High ( -0.100 ~ 2.00 MPa )
- H07 : High ( 0.00 ~ 7.00 MPa )
- H10 : High ( 0.00 ~ 10.00 MPa )
- H25 : High ( 0.00 ~ 25.0 MPa )
- H40 : High ( 0.00 ~ 40.0 MPa )

#### Output Specifications

- 02 : NPN output + RS485
- 04 : PNP output + RS485

#### Pressure Port

- F1 : R 1/4", M5
- F2 : NPT 1/4", #10-32UNF
- F3 : G 1/4" ( BSPP ) , M5

#### Piping Direction

- Blank : Rear ported
- L : Bottom ported

#### Optional Parts

- BT-10 : Mounting bracket
- BT-11 : Mounting bracket
- PA-E : Panel adapter
- PA-F : Panel adapter + Front protective lid

- I-0360 : Snubber ( for Pressure Port F1 & F3 )
- I-0379 : Snubber ( for Pressure Port F2 )

\*KP75P & KP75H suggest to select a snubber

#### Optional Parts

- Mounting Bracket : BT-10 / BT-11
- Panel Adapter : PA-E
- Panel adapter + Front protective lid : PA-F
- Snubber

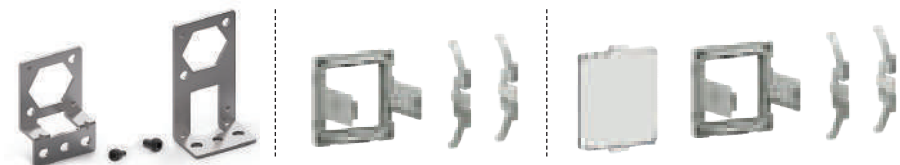

- I-0360 : for Pressure Port F1 & F3
- I-0379 : for Pressure Port F2

## Removable Snubber Installed

- Pressure port equipped with snubber can avoid damage caused by sudden pressure surge of water or oil, improve product durability.

\* When snubber is clogged with contaminants, please use a flat head screwdriver to remove the snubber, clean and reinstall.

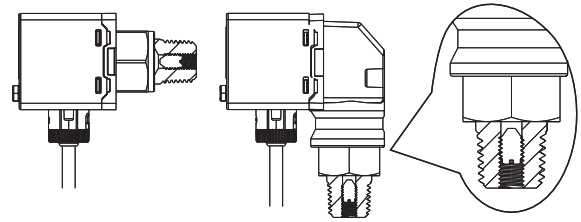

## Dimensions

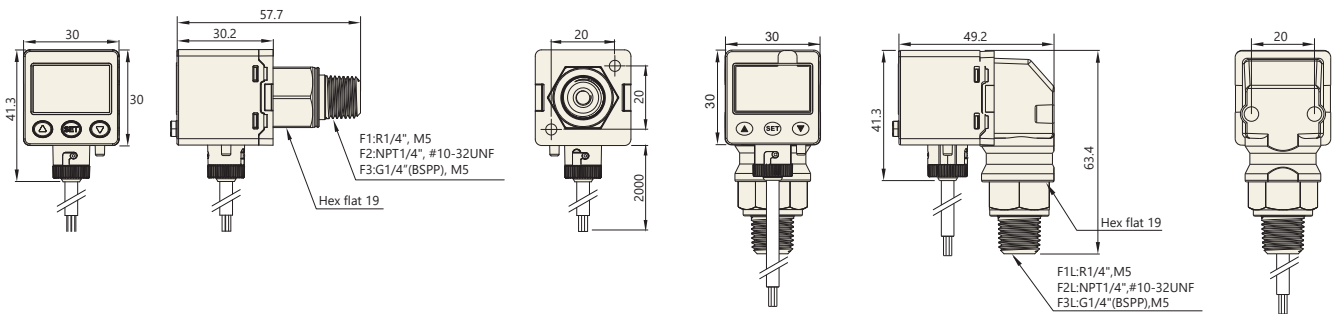

## Optional Parts Dimensions

### 1 Mounting Bracket

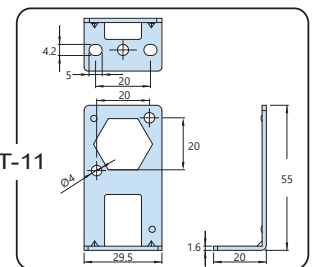
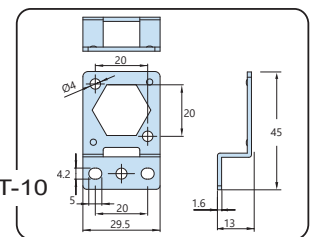
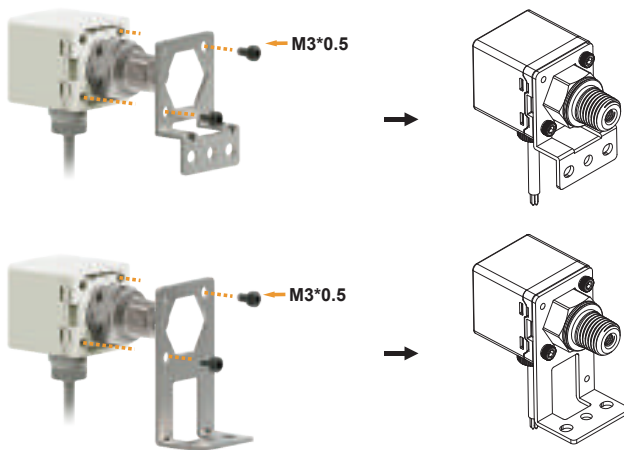

### 2 Panel Mount Adapter + Front Protective Lid

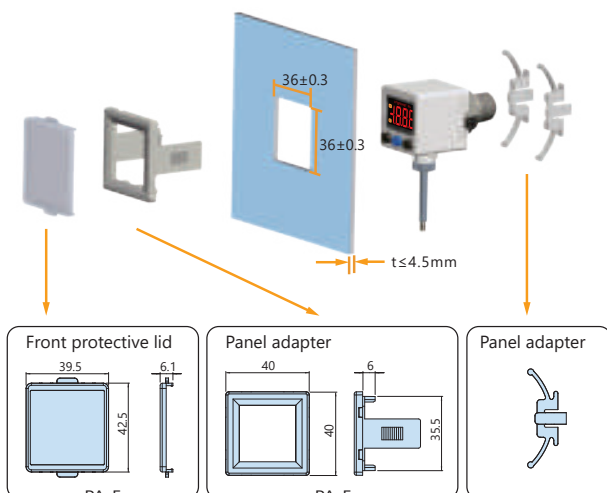

### 3 IP65 Protector

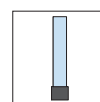
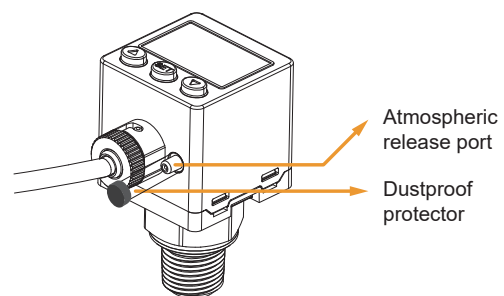

Caution :  
This device must be installed to maintain IP 65 ( Dust and splash proof ) enclosure rating.

Unit : mm

# KP90 SERIES

# Slim Pressure Sensor

## Features

- 2 output & analog output ( 1 ~ 5 V )
- 10mm width with compact size
- Key lock function
- Programmable pressure unit :  
kPa 、 MPa 、 kgf / cm<sup>2</sup> 、 bar 、 psi 、 inHg 、 mmHg

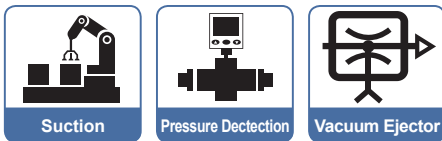

## Features Highlight

### 1 Programmable Pressure Unit

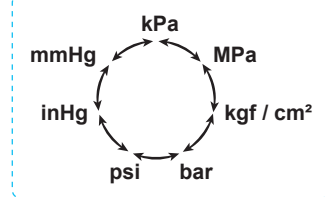

### 2 Key Lock Function

- Key lock mode to prevent unauthorized adjustments Press ⊕ and ⊖ button at the same time for 3 sec.

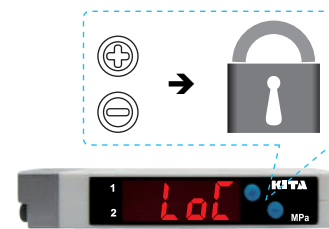

Key lock function

### 3 Analog Output

- Output range 1 to 5 V, proportional to the pressure range

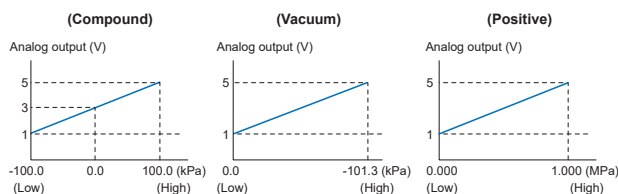

### 4 Compact Size

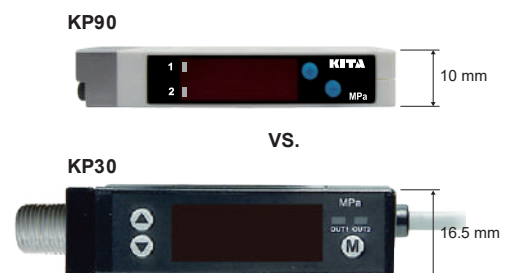

## Specifications

MODEL	KP90C (Compound)	KP90V (Vacuum)	KP90P (Positive)
Rated Pressure Range	-100.0 ~ 100.0 kPa	0.0 ~ -101.3 kPa	0.000 ~ 1.000 MPa
Set Pressure Range	-101.0 ~ 101.0 kPa	10.0 ~ -101.3 kPa	-0.100 ~ 1.000 MPa
Withstand Pressure	500 kPa		1.5 MPa
Fluid	Filtered Air, Non-corrosive / Non-flammable gas		
Set Pressure Resolution	kPa	0.1	-
	MPa	-	0.001
	kgf / cm <sup>2</sup>	0.001	0.01
	bar	0.001	0.01
	psi	0.01	0.1
	inHg	0.1	-
	mmHg	1	-
Power Supply Voltage	12 to 24 V DC $\pm 10\%$ , Ripple ( P-P ) 10 % or less		
Current Consumption	$\leq 40$ mA ( With no load )		
Switch Output	2NPN : open collector 2 outputs Max. Load Current : 125 mA Max. Supply Voltage : 30 V DC Residual Voltage : $\leq 1.5$ V	2PNP : open collector 2 outputs Max. Load Current : 125 mA Max. Supply Voltage : 24 V DC Residual Voltage : $\leq 1.5$ V	
Repeatability ( Switch Output )	$\pm 0.2\%$ F.S. $\pm 1$ digit		
Hysteresis	Hysteresis Mode	Adjustable	
	Window Comparator Mode	Fixed ( 3 digits )	
Response Time	$\leq 2.5$ ms ( chattering-proof function : 25 ms, 100 ms, 250 ms, 500 ms, 1000 ms and 1500 ms selectable )		
Output Short Circuit Protection	Yes		
Display	4 digit, 7 segment LED display ( Red ) ( Sampling rate : 5 times / sec. )		
Indicator Accuracy	$\pm 2\%$ F.S. $\pm 1$ digit ( ambient temperature : 25 $\pm 3$ °C )		
Switch on Indicator	Indicator Red : OUT1 & Indicator Green : OUT2		
Analog Output ( Voltage Output )	Output Voltage : 1 to 5 V $\pm 2.5\%$ F.S. ( within rated pressure range ) Linearity : $\pm 1\%$ F.S. Output impedance : about 1 k $\Omega$		
Environment	Enclosure	IP 40	
	Ambient Temp. Range	Operation : 0 ~ 50 °C, Storage : -10 ~ 60 °C ( No condensation or freezing )	
	Ambient Humidity Range	Operation / Storage : 35 ~ 85 % RH ( No condensation )	
	Withstand Voltage	1000 V AC in 1-min ( between case and lead wire )	
	Insulation Resistance	50 M $\Omega$ ( at 500 V DC, between case and lead wire )	
	Vibration	Total amplitude 1.5 mm or 10 G, 10 Hz - 150 Hz - 10 Hz scan for 1 minute, two hours each direction of X, Y and Z	
	Shock	980 m/s <sup>2</sup> ( 100 G ), 3 times each in direction of X, Y and Z	
Temperature Characteristic	$\pm 2\%$ F.S. of detected pressure ( 25 °C ) at temp. range of 0 ~ 50 °C		
Port Size	M5		
Lead Wire	Oil-resistance cable ( 0.14 mm <sup>2</sup> )		
Weight	Approx. 53 g ( with 2 meter lead wire )		

## Panel Description

- **Switch ( OUT1 )**  
( Red LED )
- **Switch ( OUT2 )**  
( Green LED )
- **( + ) Button**  
Use the ( + ) button to change setting mode and pre-set desired value.
- **( - ) Button**  
Use the ( - ) button to change setting mode and pre-set desired value.
- **4 Digit LED Display**  
Pressure value display.

## Output Circuit Wiring Diagrams

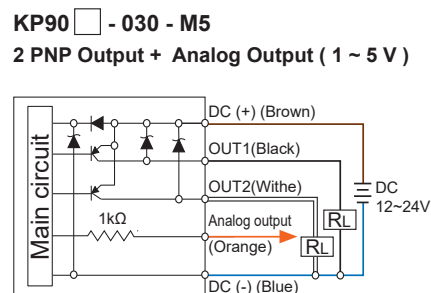
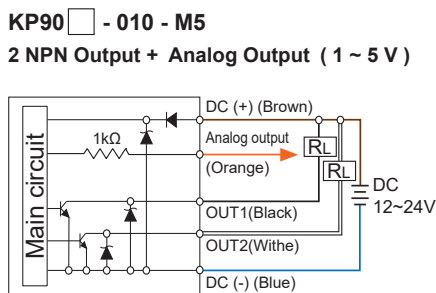

## Ordering Information

**K P 9 0 P - 0 1 0 - M 5**

### Pressure Range

C : Compound ( -101.0 ~ 101.0 kPa )  
V : Vacuum ( 10.0 ~ -101.3 kPa )  
P : Positive ( -0.100 ~ 1.000 MPa )

### Output Specification

010 : 2 NPN output & Analog output ( 1 ~ 5 V )  
030 : 2 PNP output & Analog output ( 1 ~ 5 V )

## Installation Precautions

- When mounting, always use the wrench on the metallic area near the pressure port. Never apply a wrench to the plastic body, it will damage the sensor.
- Do not use a sharp tool to insert the pressure inlet to avoid damaging the sensor chip.
- Do not use the product in an environment that is exposed to the splash of water or dust. Otherwise failure or malfunction may occur.

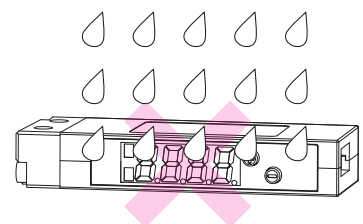
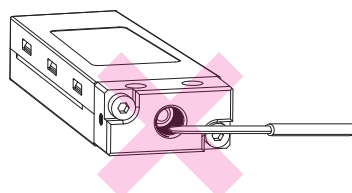
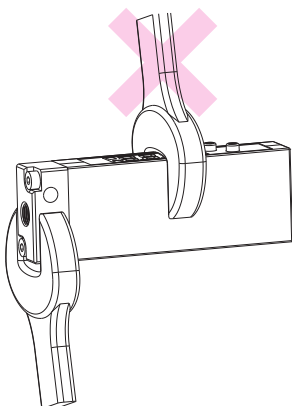

## Dimensions

KP90□ - □ - M5

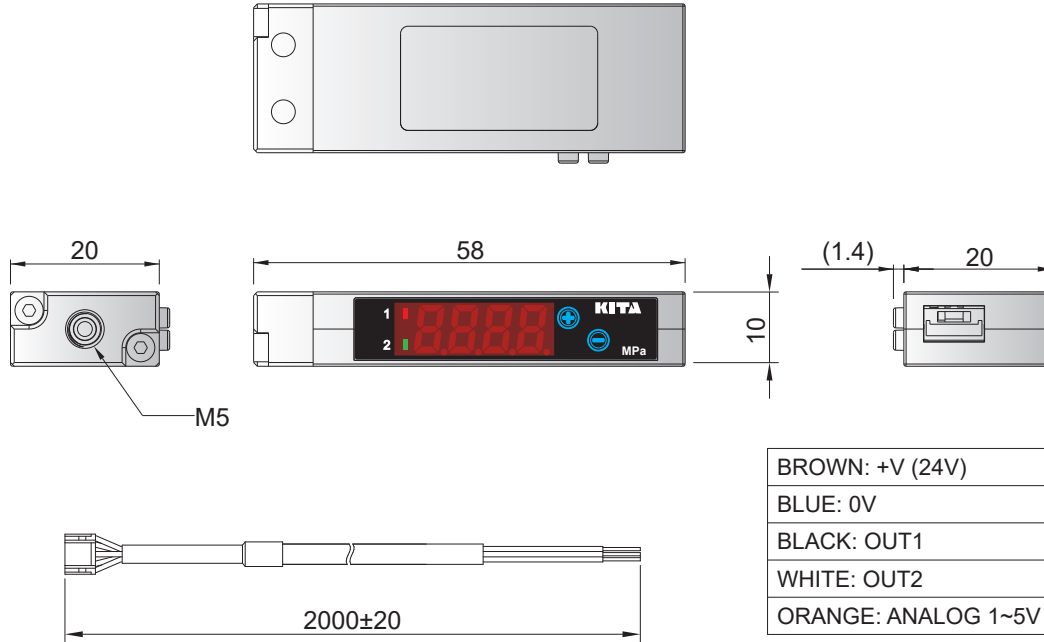

Unit : mm

## Features

- 3-color digital LCD display
- Programmable pressure unit :  
kPa、MPa、kgf/cm<sup>2</sup>、bar、psi、inHg、mmHg
- Dual LCD display allows setting value to be displayed
- Key lock indicator
- Analog output : 1 ~ 5 V or 4 ~ 20 mA
- Sensor input : 1 ~ 5 V or 4 ~ 20 mA
- 12 pressure ranges for transducer

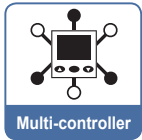
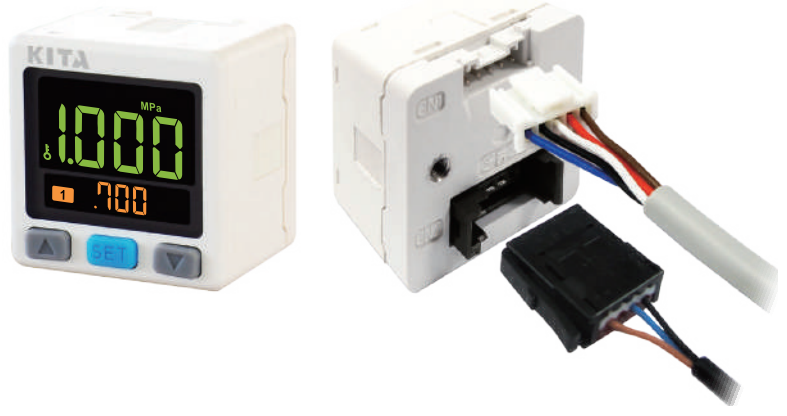

## Features Highlight

### 1 3-Color Digital LCD Display

- Main display color change with output status  
Green ↔ Red

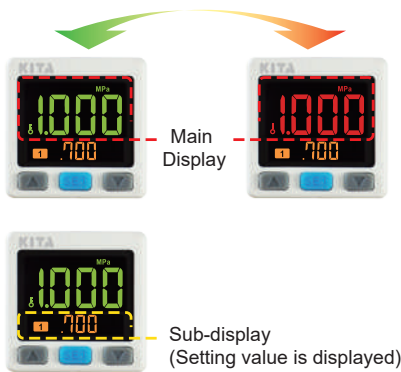

### 2 Programmable Pressure Unit

- User selectable pressure unit is indicated on the sub-display section, eliminate pressure unit label
- 7 user programmable pressure units available



### 3 Save Installation Space

Panel opening for multiple pressure controller



Calculation factor (A) = (34.4 x n) - 3.4  
n = number of controller

Actual dimension after installation



### 4 Key Lock Function

- Key lock icon is shown on the display when the function is enabled

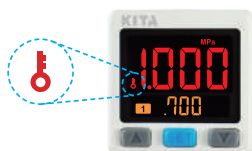

### 5 12 Pressure Ranges for Transducer

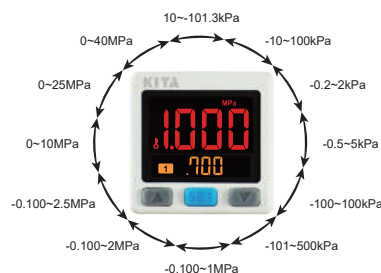

### 6 Analog Output / Sensor Input

- Current output or voltage output is available

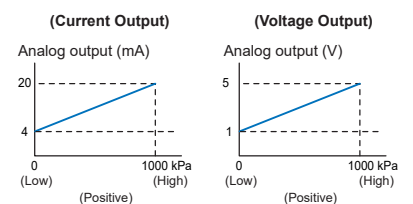



## Specifications

MODEL		KP400														
Sensor Type		S - 0	S - 1	S - 2	S - 3	S - 4	S - 5	S - 6	S - 7	S - 8	S - 9	S - 10	S - 11	S - 12		
		Rated Pressure Range		Self-Setting	0 ~ -101.3 kPa	0 ~ 100 kPa	0 ~ 2 kPa	0 ~ 5 kPa	-100 ~ 100 kPa	-101 ~ 500 kPa	0 ~ 1 MPa	0 ~ 2 MPa	0 ~ 2.5 MPa	0 ~ 10 MPa	0 ~ 25 MPa	0 ~ 40 MPa
		Setting Pressure Range		*1	10 ~ -101.3 kPa	-10 ~ 100 kPa	-0.2 ~ 2 kPa	-0.5 ~ 5 kPa	-100 ~ 100 kPa	-101 ~ 500 kPa	-0.100 ~ 1 MPa	-0.100 ~ 2 MPa	-0.100 ~ 2.5 MPa	0 ~ 10 MPa	0 ~ 25 MPa	0 ~ 40 MPa
		Setting Pressure Range ( Auto-Shift Input )		-	101.3 ~ -101.3 kPa	-100 ~ 100 kPa	-2 ~ 2 kPa	-5 ~ 5 kPa	-100 ~ 100 kPa	-500 ~ 500 kPa	-1 ~ 1 MPa	-2 ~ 2 MPa	-2.5 ~ 2.5 MPa	-10 ~ 10 MPa	-25 ~ 25 MPa	-40 ~ 40 MPa
		Set Pressure Resolution		Self-Setting	kPa	0.1	0.1	0.01	0.01	0.1	1	-	-	-	-	-
MPa	-				-	-	-	-	-	0.001	0.01	0.01	0.01	0.1	0.1	
kgf / cm <sup>2</sup>	0.001				0.001	-	-	0.001	0.01	0.01	0.1	0.1	0.1	0.1	1	1
bar	0.001				0.001	-	-	0.001	0.01	0.01	0.1	0.1	0.1	0.1	1	1
psi	0.01				0.01	-	-	0.01	0.1	0.1	0.1	1	1	1	1 *2	1 *2
inHg	0.1				-	-	-	0.1	-	-	-	-	-	-	-	-
mmHg	1				-	0.1	0.1	1	-	-	-	-	-	-	-	-
---	-				-	-	-	-	-	-	-	-	-	-	-	-
Power Supply Voltage		12 to 24 V DC ± 10 %, Ripple ( P-P ) ≤ 10 %														
Current Consumption		≤ 40 mA ( With no load )														
Sensor Input		1 ~ 5 V 或 4 ~ 20 mA														
Switch Output		2NPN : open collector 2 outputs Max. Load Current : 125 mA Max. Supply Voltage : 30 V DC Residual Voltage : ≤ 1.5 V						2NPN : open collector 2 outputs Max. Load Current : 125 mA Max. Supply Voltage : 24 V DC Residual Voltage : ≤ 1.5 V								
Repeatability ( Switch Output )		± 0.1 % F.S. ± 1 digit														
Hysteresis	One Point Set Mode	Adjustable *3														
	Hysteresis Mode															
	Window Comparator Mode															
Response Time		≤ 2.5 ms ( chattering-proof function : 25 ms, 100 ms, 250 ms, 500 ms, 1000 ms and 1500 ms selectable )														
Output Short Circuit Protection		Yes														
Display		3 ½ digital, 7 segment LCD display ( Red / Green / Orange ) ( Sampling rate : 5 times / sec. )														
Indicator Accuracy		± 1 % F.S. ± 1 digit ( Ambient temperature : 25 ± 3 °C )														
Switch on Indicator		Orange indicator 1 : OUT1 & Orange indicator 2 : OUT2														
Analog output ( Voltage Output ) *4		Output Voltage : 1 to 5 V ± 2 % F.S. ( within rated pressure range ) Linearity : ± 1 % F.S. Output impedance : about 1 kΩ														
Analog output ( Current Output ) *5		Output Current : 4 to 20 mA ± 2 % F.S. ( within rated pressure range ) Linearity : ± 1 % F.S. Max.Load impedance : 300 Ω at power supply of 12 V, 600 Ω at power supply of 24 V Min.Load impedance : 50 Ω														
Environment	Enclosure	IP40														
	Ambient Temp. Range	Operation : 0 ~ 50 °C, storage : -10 ~ 60 °C ( No condensation or freezing )														
	Ambient Humidity Range	Operation / Storage : 35 ~ 85 % RH ( No condensation )														
	Withstand Voltage	1000 V AC in 1-min ( between case and lead wire )														
	Insulation Resistance	50 MΩ ( at 500 V DC, between case and lead wire )														
	Vibration	Total amplitude 1.5 mm or 10 G, 10 Hz - 55 Hz - 10 Hz scan for 1 minute, two hours each direction of X, Y and Z														
	Shock	100 m/s <sup>2</sup> ( 10 G ), 3 times each in direction of X, Y and Z														
Temperature Characteristic		± 0.5 % F.S. of detected pressure ( 25 °C ) at temp. Range of 0 ~ 50 °C														
Lead Wire		Ø4 Oil-resistance cable ( PVC ) - 26 AWG ( 0.15 mm <sup>2</sup> ) - 5 cores														
Weight ( with 2 meter lead wire )		Approx. 67 g														

### NOTE :

\*1 : S-0 : Set the sensor range ( 1999 ~ -1999 ) by self. The decimal place can be adjusted.

\*2 : If set pressure unit is psi, the value requires to ten multiply by display value.

\*3 : Hysteresis value is adjustable within 1 ~ 8 digits for one point set mode and window comparator mode.

\*4 : If analog voltage output is selected, the analog current output cannot be selected at the same time.

\*5 : If analog current output is selected, the analog voltage output cannot be selected at the same time.

## Panel Description

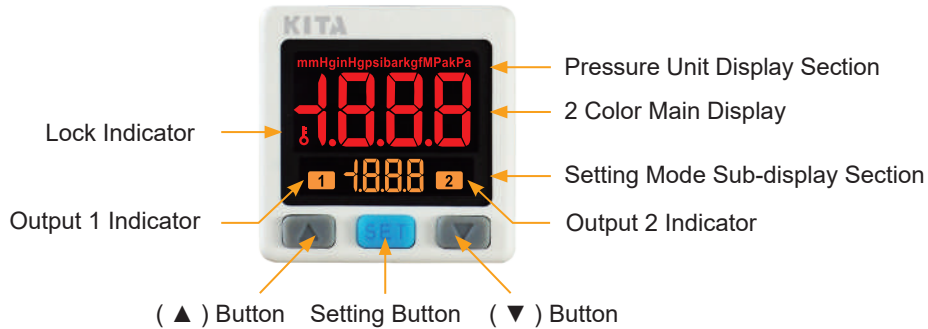

## Output Circuit Wiring Diagrams

### KP4 □ 0 - 010

2 NPN + Analog Output ( 1 ~ 5 V )

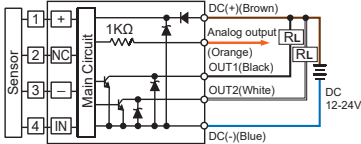

### KP4 □ 0 - 030

2 PNP + Analog Output ( 1 ~ 5 V )

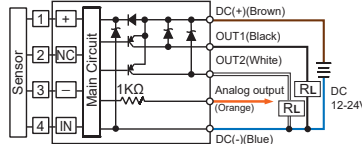

### KP4 □ 0 - 05

2 NPN Output + Auto-shift input

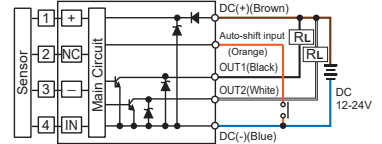

### KP4 □ 0 - 011

2 NPN + Analog Output ( 4 ~ 20 mA )

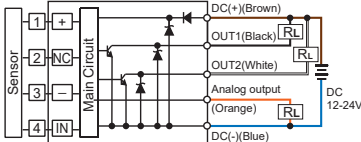

### KP4 □ 0 - 031

2 PNP + Analog Output ( 4 ~ 20 mA )

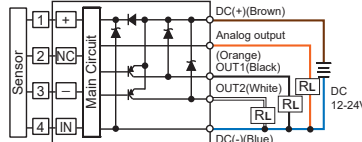

### KP4 □ 0 - 07

2 PNP Output + Auto-shift input

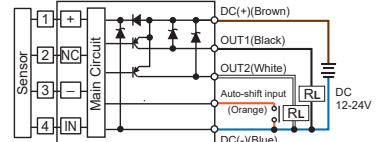

## Ordering Information

**K P 4 1 0 - 0 1 0**

### Input Specifications

- 1 : Voltage input
- 2 : Current input

### Output Channel

- 0 : 1 Channel

### Input / Output Specifications

- 010 : 2 NPN outputs & Analog output ( 1 ~ 5 V )
- 011 : 2 NPN outputs & Analog output ( 4 ~ 20 mA )
- 030 : 2 PNP outputs & Analog output ( 1 ~ 5 V )
- 031 : 2 PNP outputs & Analog output ( 4 ~ 20 mA )
- 05 : 2 NPN outputs & Auto-shift input
- 07 : 2 PNP outputs & Auto-shift input

### Optional Parts

- BT-8 : Mounting bracket
- BT-9 : Mounting bracket
- PA-C : Panel adapter
- PA-D : Panel adapter + Front protective lid
- CN-0046A : Sensor connector  $\varnothing 0.8 \sim \varnothing 1.0$  mm, 26~24AWG
- CN-0046B : Sensor connector  $\varnothing 1.0 \sim \varnothing 1.2$  mm, 26~24AWG
- CN-0046C : Sensor connector  $\varnothing 1.2 \sim \varnothing 1.6$  mm, 26~24AWG
- KP10 □ -01 : Transducer

### Optional Parts

- Mounting Bracket : BT-8 / BT-9



- Sensor Connector  
CN - 0046 □



- Transducer  
KP10 □ - 01

- Panel Adapter : PA-C



- Panel Adapter + Front Protective Lid : PA-D



## Dimensions

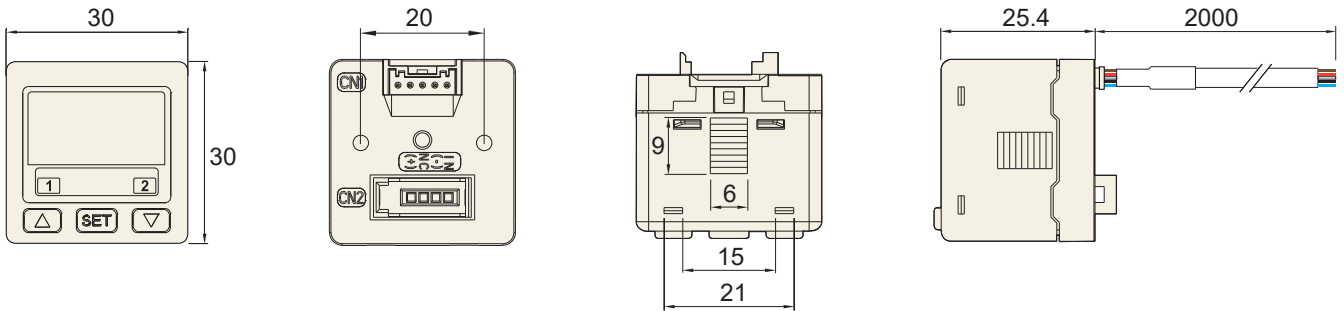

## Optional Parts Dimensions

### 1 Mounting Bracket

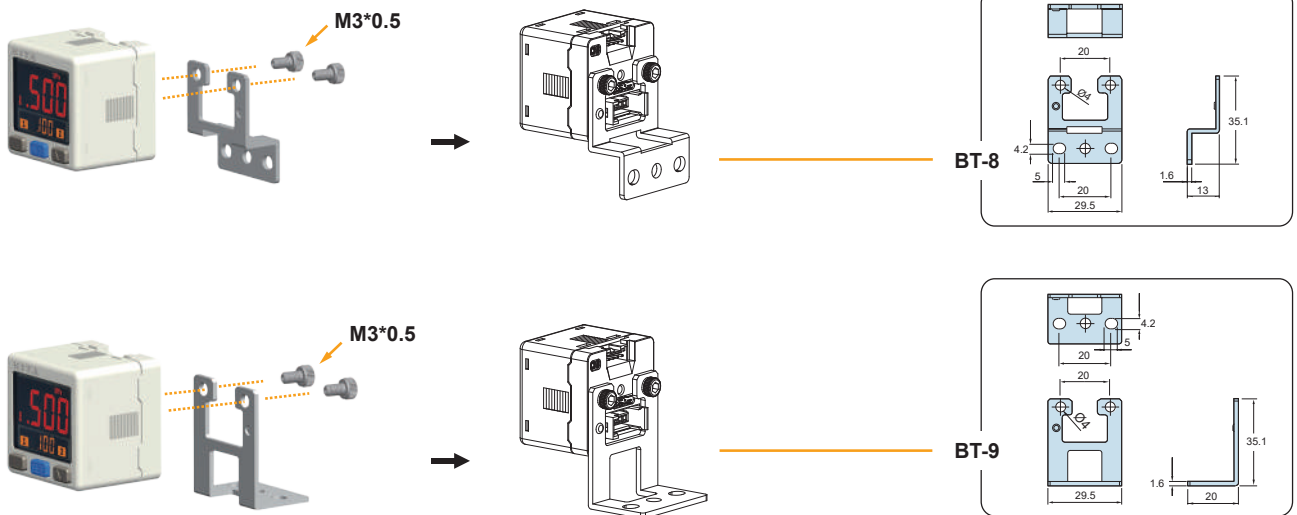

### 2 Panel Mount Adapter + Front Protective Lid

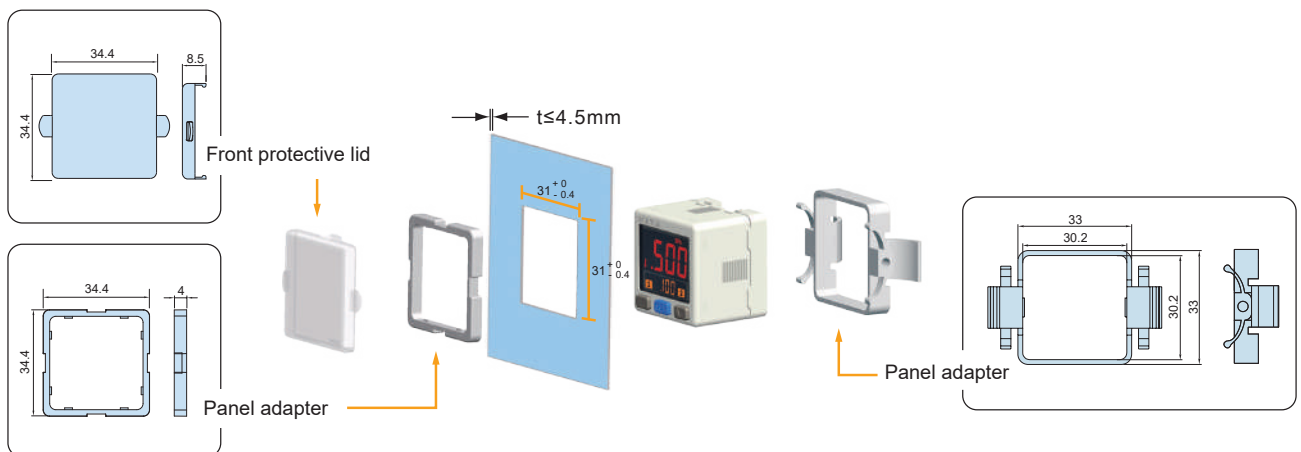

Unit : mm

## Features

- Differential pressure sensor
- Analog output : 1 ~ 5 V or 4 ~ 20 mA
- Pressure range : 0 ~ 2 kPa or 0 ~ 5 kPa
- Simple installation, applicable to Ø6 air tubing
- IP40 enclosure

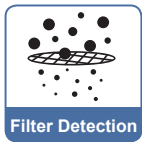

## Features Highlight

### 1 Simple Installation

- Plug-in port for air tube

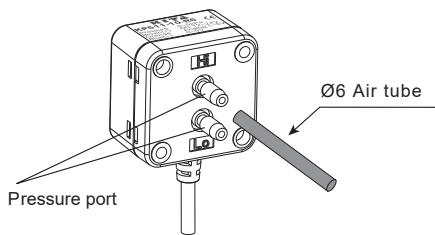

- Plug connect with controller

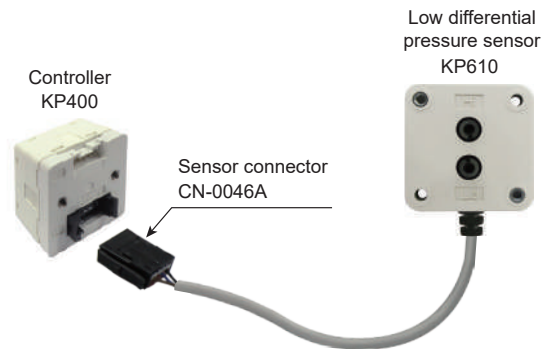

### 2 Analog Output

- 1 Analog output

Output range 1 to 5 V or 4 to 20 mA, proportional to the pressure range

Analog output (mA)

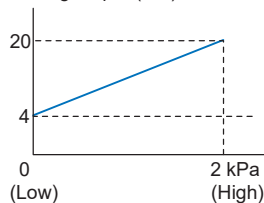

Analog output (V)

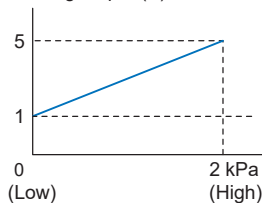

Analog output (mA)

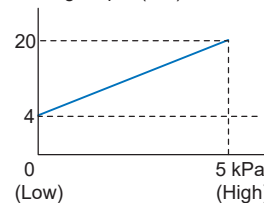

Analog output (V)

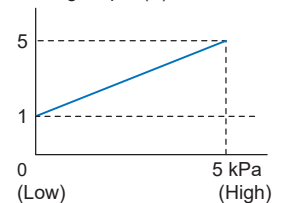

## Specifications

MODEL	KP611	KP612
Rated Differential Pressure Range	0 ~ 5 kPa	0 ~ 2 kPa
Operating Pressure Range	-50 ~ 50 kPa *1	
Withstand Pressure	65 kPa	
Fluid	Filtered air, Non-corrosive / Non-flammable gas	
Power Supply Voltage	12 to 24 V DC $\pm 10\%$ , Ripple ( P-P ) 10 % or less	
Current Consumption	$\leq 15$ mA ( With no load )	
Analog Output ( Voltage Output )	Output Voltage : 1 to 5 V $\pm 1\%$ F.S. ( within rated pressure range ) Linearity : $\pm 0.5\%$ F.S. Output impedance : about 1 k $\Omega$	
Analog Output ( Current Output )	Output Current : 4 to 20 mA $\pm 1\%$ F.S. ( within rated pressure range ) Linearity : $\pm 0.5\%$ F.S. Max.Load impedance : 250 $\Omega$ at power supply of 12 V 600 $\Omega$ at power supply of 24 V	
Environment	Enclosure	IP 40
	Ambient Temp. Range	Operation : 0 ~ 50 °C, Storage : -20 ~ 70 °C ( No condensation or freezing )
	Ambient Humidity Range	Operation / Storage : 35 ~ 85 % RH ( No condensation )
	Withstand Voltage	1000 V AC in 1-min ( between case and lead wire )
	Insulation Resistance	50 M $\Omega$ ( at 500 V DC, between case and lead wire )
	Vibration	Total amplitude 1.5 mm or 10 G, 10 Hz - 150 Hz - 10 Hz scan for 1 minute, two hours each direction of X, Y and Z
	Shock	300 m/s <sup>2</sup> ( 30 G ), 3 times each in direction of X, Y and Z
Temperature Characteristic	$\pm 3\%$ F.S. of detected pressure ( 25 °C ) at temp. Range of 0 ~ 50 °C	
Port Size	4.8 ( $\varnothing 4.4$ in the end ) resin pipe ( Applicable to $\varnothing 6$ air tube )	
Lead Wire	Oil-resistance cable ( 0.15 mm <sup>2</sup> )	
Weight	Approx. 75 g ( with 2-meter lead wire )	

**NOTE :**

\*1 : To detect differential pressure from 0 ~ 2 kPa or 0 ~ 5 kPa within the range of -50 ~ 50 kPa.

## Circuit Wiring Diagrams

### KP61 □ - 10 - R6

Analog Output ( 1 ~ 5 V )

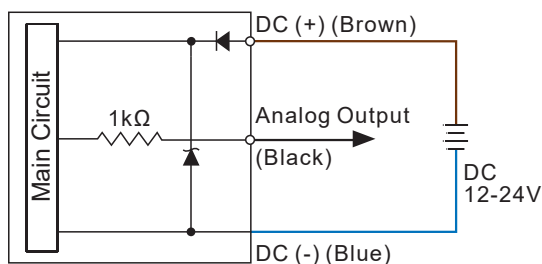

### KP61 □ - 11 - R6

Analog Output ( 4 ~ 20 mA )

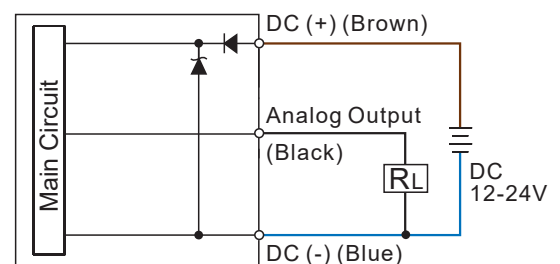

# KP610 SERIES

# Differential Pressure Sensor

## Ordering Information

K P 6 1 1 - 1 0 - R 6

### Pressure Range

- 1 : 0 ~ 5 kPa
- 2 : 0 ~ 2 kPa

### Output Specifications

- 10 : Analog output ( 1 ~ 5 V )
- 11 : Analog output ( 4 ~ 20 mA )

### Optional Parts

- BT-16 : Mounting bracket

## Dimensions

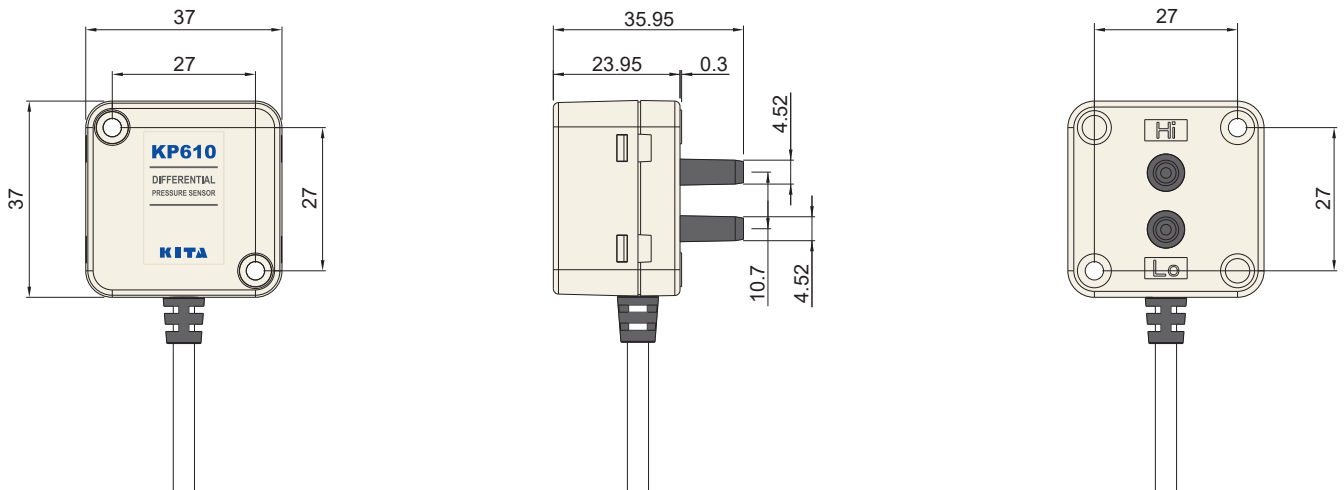

## Optional Parts Dimensions

### Mounting Bracket

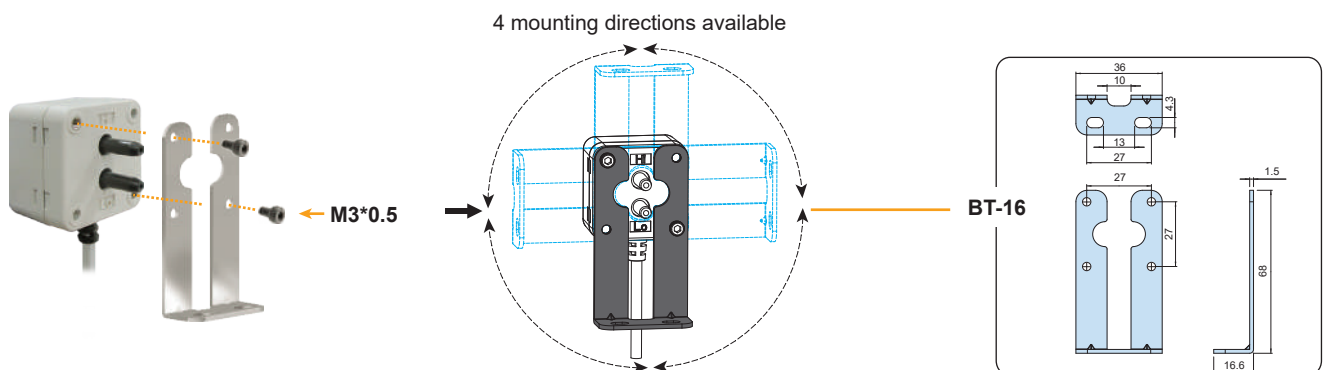

Unit : mm

## Application

### 1 Air Flow Detection

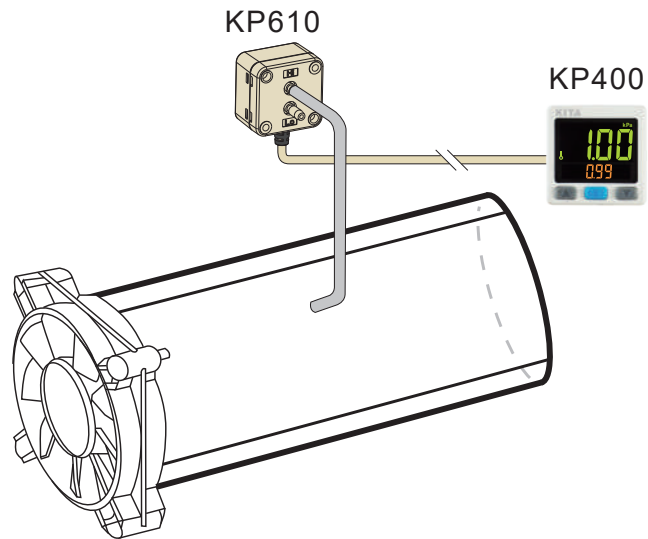

### 2 Filter Air Monitoring

To monitor the clogging of filter by detecting the differential pressure.

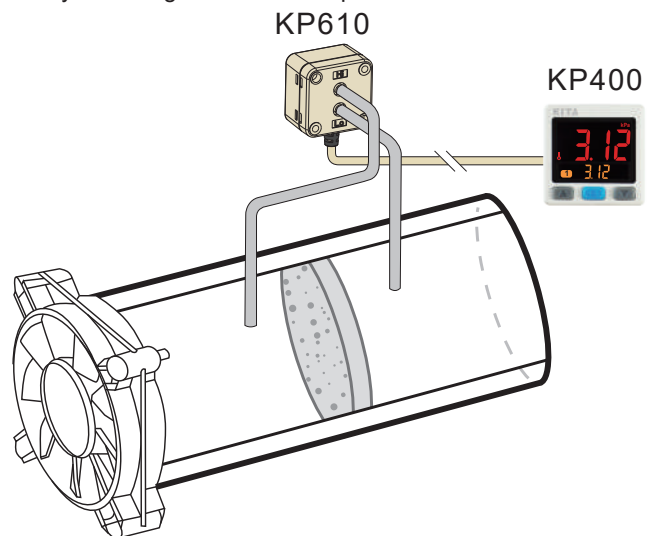

## Features

- Digital LCD display, easy readout
- Analog output : 1 ~ 5 V or 4 ~ 20 mA
- IP40 enclosure
- Pressure range :  
0 ~ 1 kPa, 0 ~ 2 kPa, 0 ~ 5 kPa  
-1 ~ 1 kPa, -2 ~ 2 kPa, -5 ~ 5 kPa



## Features Highlight

### 1 Quick Installation

- Save Installation Time
- Easy Removal

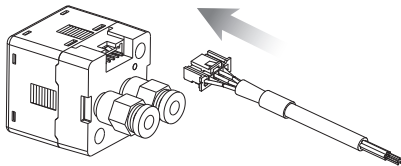

( Removable data cable )

### 2 Key Lock Function

- Key lock icon is shown on the display when the function is enabled.



### 3 Save Installation Space

Panel opening for multiple pressure controller

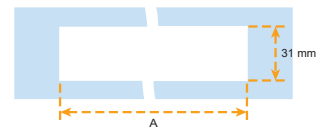

Calculation factor (A) = (34.4 x n) - 3.4  
n = number of controller

Actual dimension after installation



### 4 Air Flow Detection

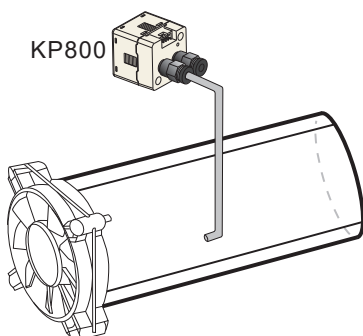

### 5 Filter Air Monitoring

- To monitor the clogging of filter by detecting the differential pressure.

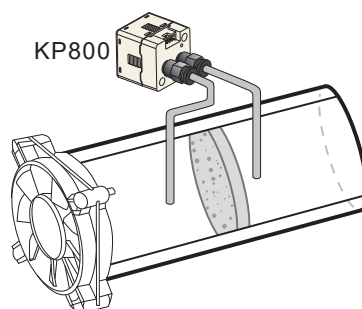

## Specifications

MODEL	KP801	KP811	KP802	KP812	KP805	KP815
<b>Rated Pressure Range</b>	0 ~ 1000 Pa	-1000 ~ 1000 Pa	0.00 ~ 2.00 kPa	-2.00 ~ 2.00 kPa	0.0 ~ 5.00 kPa	-5.00 ~ 5.00 kPa
<b>Setting Pressure Range</b>	-100 ~ 1000 Pa	-1000 ~ 1000 Pa	-0.20 ~ 2.00 kPa	-2.00 ~ 2.00 kPa	-0.50 ~ 5.00 kPa	-5.00 ~ 5.00 kPa
<b>Withstand Pressure</b>	3 kPa		6 kPa		15 kPa	
<b>Fluid</b>	Filtered air, Non-corrosive / Non-flammable gas					
<b>Set Pressure</b>	Pa	1	-			
<b>Resolution</b>	kPa	-	0.01			
<b>Power Supply Voltage</b>	12 ~ 24 V DC $\pm$ 10 %, Ripple ( P-P ) $\leq$ 10 %					
<b>Current Consumption</b>	$\leq$ 40 mA ( with no load )					
<b>Switch Output</b>	2 NPN : open collector 2 outputs Max. Load Current : 125 mA Max. Supply Voltage : 30 V DC Residual Voltage : $\leq$ 1.5 V			2 PNP : open collector 2 outputs Max. Load Current : 125 mA Max. Supply Voltage : 24 V DC Residual Voltage : $\leq$ 1.5 V		
<b>Repeatability ( Switch Output )</b>	$\pm$ 0.5 % F.S. $\pm$ 1 digit					
<b>Hysteresis</b>	<b>Hysteresis Mode</b>	Adjustable				
	Window Comparator Mode					
<b>Response Time</b>	$\leq$ 2.0 ms ( Chattering-proof function : 32 ms, 128 ms, 1024 ms selectable )					
<b>Output Short Circuit Protection</b>	Yes					
<b>Display</b>	3 ½ digital, 7 segment LCD display ( White ) ( Sampling rate : 5 times / sec. )					
<b>Indicator Accuracy</b>	$\pm$ 2 % F.S. $\pm$ 1 digit ( Ambient temperature : 25 $\pm$ 3 °C )					
<b>Switch on Indicator</b>	White Indicator 1 : OUT1 & White Indicator 2 : OUT2					
<b>Analog Output ( Voltage Output ) *1</b>	Output Voltage : 1 ~ 5 V $\pm$ 2.5 % F.S. ( within rated pressure range ) Linearity : $\pm$ 1 % F.S. Output Impedance : about 1 k $\Omega$					
<b>Analog output ( Current Output ) *2</b>	Output Current : 4 ~ 20 mA $\pm$ 2.5 % F.S. ( within rated pressure range ) Linearity : $\pm$ 1 % F.S. Max. Load Impedance : 250 $\Omega$ at power supply of 12 V 600 $\Omega$ at power supply of 24 V Min. Load Impedance : 50 $\Omega$					
<b>Environment</b>	<b>Enclosure</b>	IP40				
	<b>Ambient Temp. Range</b>	Operation : 0 ~ 50 °C, Storage : -10 ~ 60 °C ( No condensation or freezing )				
	<b>Ambient Humidity Range</b>	Operation / Storage : 35 ~ 85 % RH ( No condensation )				
	<b>Withstand Voltage</b>	1000 V AC in 1-min ( between case and lead wire )				
	<b>Insulation Resistance</b>	50 M $\Omega$ ( at 500 V DC, between case and lead wire )				
	<b>Vibration</b>	Total amplitude 1.5 mm or 10 G, 10 Hz ~ 150 Hz ~ 10 Hz scan for 1 minute, 2 hours each direction of X, Y and Z				
	<b>Shock</b>	100 m/s <sup>2</sup> ( 10 G ), 3 times each in direction of X, Y and Z				
<b>Temperature Characteristic</b>	$\pm$ 3 % F.S. of detected pressure ( 25 °C ) at temp. Range of 0 ~ 50 °C					
<b>Port Size</b>	M5					
<b>Lead Wire</b>	$\phi$ 4 Oil-resistance cable ( PVC ) - 26 AWG ( 0.15 mm <sup>2</sup> ) - 5 cores					
<b>Weight ( with 2 meter lead wire )</b>	Approx. 75 g					

**NOTE :**

\*1 : If analog voltage output is selected, the analog current output cannot be selected at the same time.

\*2 : If analog current output is selected, the analog voltage output cannot be selected at the same time.

# KP800 SERIES

# Differential Pressure Sensor

## Panel Description

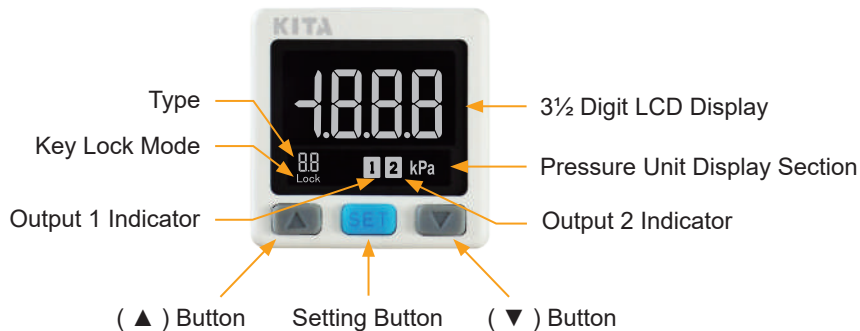

## Installation Precautions

- When mounting, always use the wrench on the metallic area near the pressure port. Never apply a wrench to the plastic body, it will damage the sensor.
- Over tightening may cause damages to the port thread, mounting bracket and pressure sensor. Under tightening may result loosen or leakage.
- Apply pressure and power after installation and make necessary adjustments and inspect any possible signs of leakage to ensure proper installation.

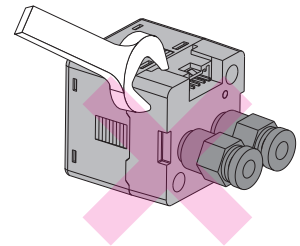
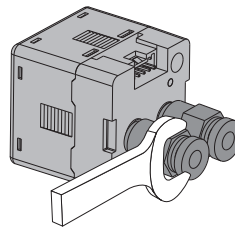

## Output Circuit Wiring Diagrams

### KP8□ - 010 - M5

2 NPN + Analog Output (1 ~ 5 V)

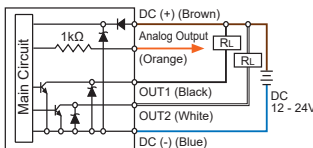

### KP8□ - 030 - M5

2 PNP + Analog Output (1 ~ 5 V)

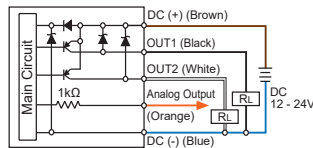

### KP8□ - 011 - M5

2 NPN + Analog Output (4 ~ 20 mA)

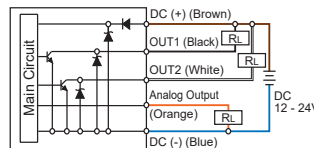

### KP8□ - 031 - M5

2 PNP + Analog Output (4 ~ 20 mA)

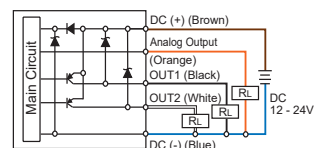

## Ordering Information

**K P 8 0 1 - 0 1 0 - M 5**

### Pressure Range

01 : (-100 ~ 1000 Pa)    11 : (-1000 ~ 1000 Pa)  
 02 : (-0.20 ~ 2.00 kPa)    12 : (-2.00 ~ 2.00 kPa)  
 05 : (-0.50 ~ 5.00 kPa)    15 : (-5.00 ~ 5.00 kPa)

### Output Specifications

010 : 2 NPN output + Analog output (1 ~ 5 V)  
 011 : 2 NPN output + Analog output (4 ~ 20 mA)  
 030 : 2 PNP output + Analog output (1 ~ 5 V)  
 031 : 2 PNP output + Analog output (4 ~ 20 mA)

### Optional Parts

BT-20 : Mounting bracket  
 BT-21 : Mounting bracket  
 PA-C : Panel adapter  
 PA-D : Panel adapter + Front protective lid

### Optional Parts

- Mounting Bracket : BT-20 / BT-21

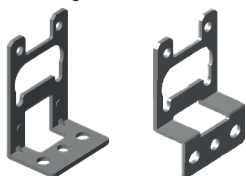

- Panel Adapter : PA-C

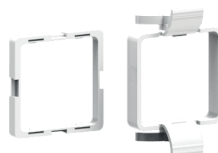

- Panel Adapter + Front Protective Lid : PA-D



## Dimensions

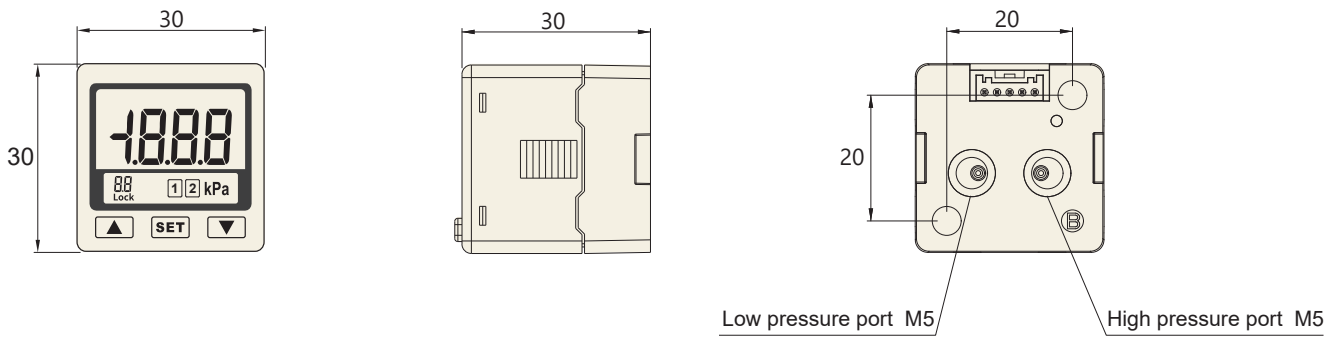

## Optional Parts Dimensions

### 1 Mounting Bracket

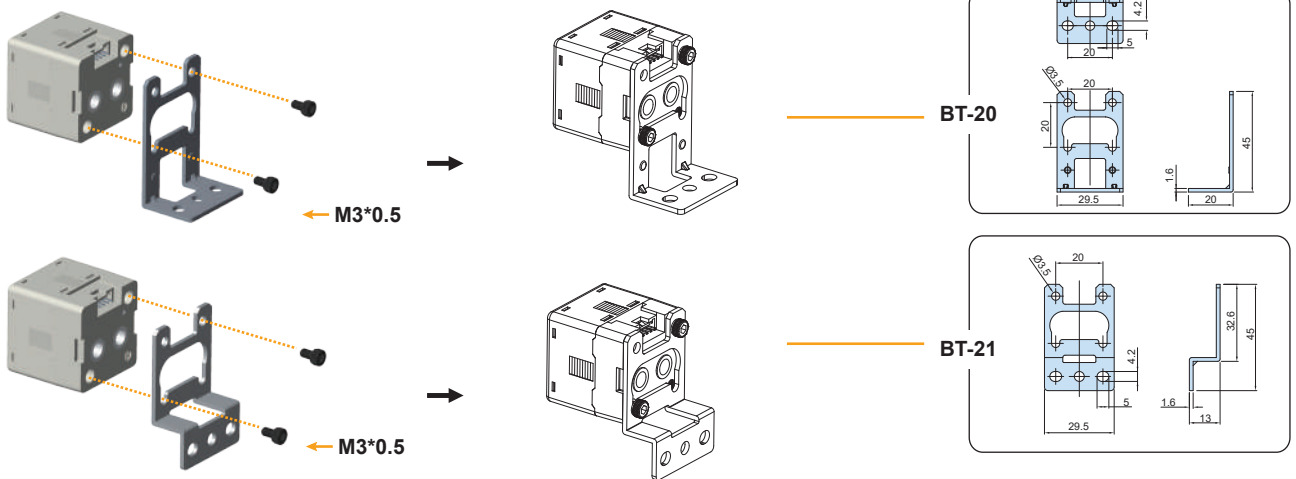

### 2 Panel Mount Adapter + Front Protective Lid

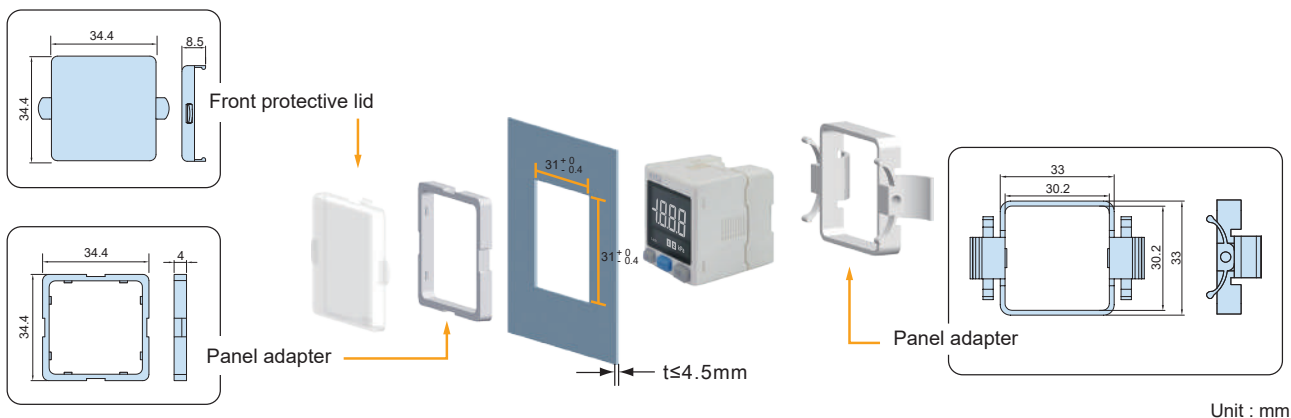

Unit : mm

## Features

- Digital LCD display, easy readout
- IP65 enclosure
- Detection distance : 0.01 ~ 0.10 mm
- Repeatability :  $\pm 5 \mu\text{m}$



## Features Highlight

### 1 Easy to Check Workpiece Located on the Right Place

- Intuitive recognize in graphic interface, easy to check the gap between workpiece and platform.

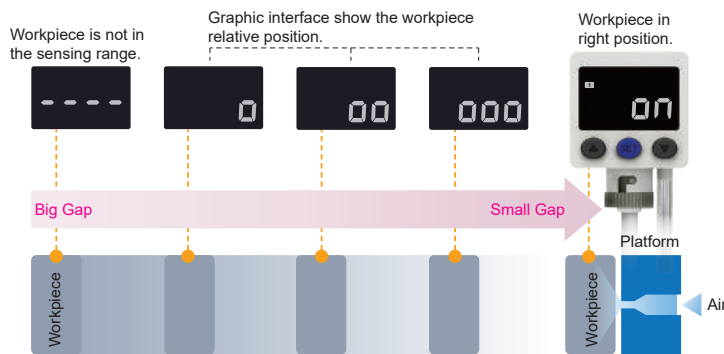

### 2 IP65 Compliance



### 3 Reference Gap Easy Setting

- To set the reference gap by press up  $\Delta$  + down  $\nabla$  at the same time.

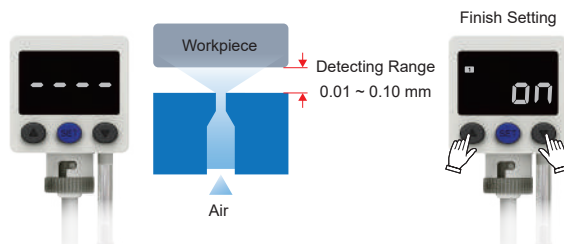

### 4 Repeatability : $\pm 5 \mu\text{m}$

- The higher repeatability is, the more guarantee is.

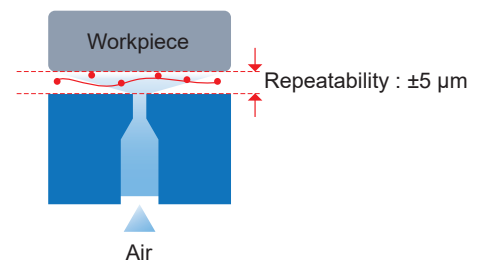

### 5 The Gap Cause by Shavings Can Be Detectable

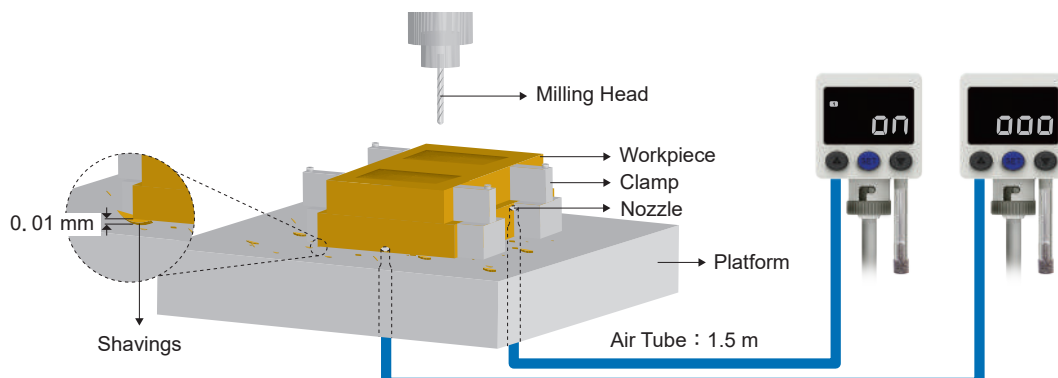

## Specifications

MODEL	KGS01-G-02	KGS01-G-04
Detection Distance	0.01 ~ 0.10 mm	
Operating Pressure Range	250 to 350 kPa	
Withstand Pressure	600 kPa	
Fluid	Clean air, Non-corrosive / Non-flammable gas *1	
Power Supply Voltage	12 to 24 V DC $\pm 10\%$ , Ripple (p-p) 10 % or less	
Current Consumption	$\leq 20$ mA	
Switch Output	1NPN : open collector 1 output Max. Load Current : 125 mA Max. Supply Voltage : 30 V DC Residual Voltage : $\leq 1.5$ V	1PNP : open collector 1 output Max. Load Current : 125 mA Max. Supply Voltage : 24 V DC Residual Voltage : $\leq 1.5$ V
Consumption Flow Rate	18 L / min @ 300 kPa or less	
Repeatability	$\pm 5$ $\mu$ m	
Hysteresis	Adjustable 1 ~ 30 digits	
Output Short Circuit Protection	Yes	
Display	3 1/2 digital, 7 segment LCD display ( White ) ( Sampling rate : 5 times / sec. )	
Switch on Indicator	White indicator 1 : OUT	
Detection Nozzle	$\phi 1.5$ mm *2	
Piping Specifications	Supply Port	Rc1/8" *3
	Detection Port	Rc1/8" *3
Environment	Enclosure	IP 65 *4
	Ambient Temp. Range	Operation : 0 ~ 50 °C, Storage : -10 ~ 60 °C ( No condensation or freezing )
	Ambient Humidity Range	Operation / Storage : 35 ~ 85 % RH ( No condensation )
	Vibration	Total amplitude 1.5 mm, 10 Hz ~ 55 Hz ~ 10 Hz scan for 1 minute, two hours each direction of X, Y and Z
Lead wire	Oil-resistance cable ( 0.15 mm <sup>2</sup> )	
Weight ( with 2 meter lead wire )	Approx. 115 g	

Note :

\*1 : Please use air filter to clean air ( 5 $\mu$ m or less ) and install precision regulator.

\*2 : Detection nozzle

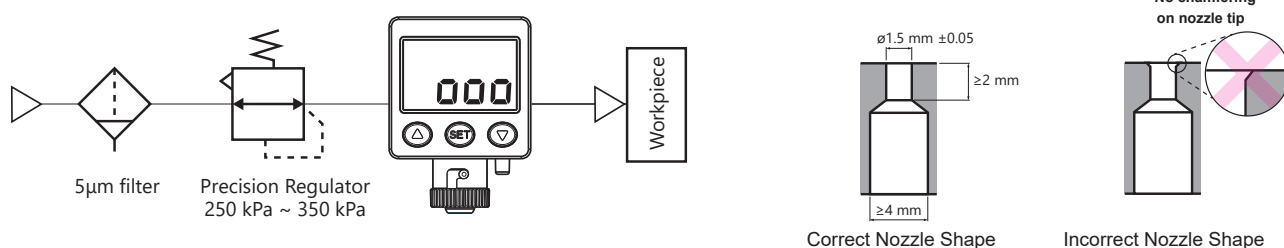

\*3 : Back side of product, please refer to product dimension.

\*4 : Dust protector is required to maintain IP 65 enclosure. Please refer to "Optional Parts Dimensions".

## Detection Circuit

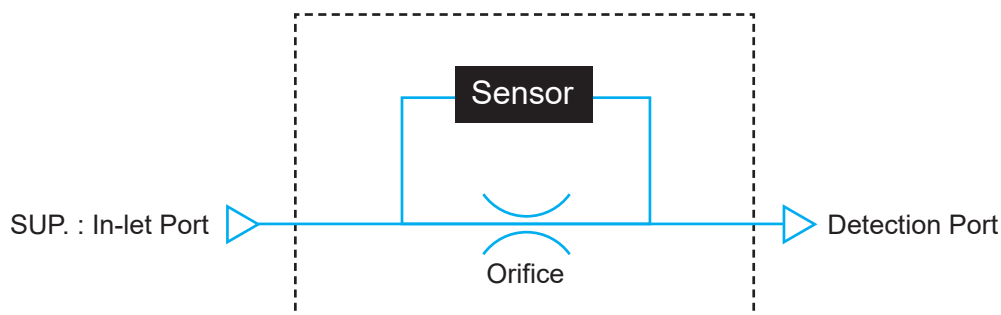

## Panel Description



## Installation Precautions

- When mounting, always use the wrench on the metallic area near the pressure port. Never apply a wrench to the plastic body, it will damage the sensor.
- Over tightening may cause damages to the port thread, mounting bracket and pressure sensor. Under tightening may result loosen or leakage.

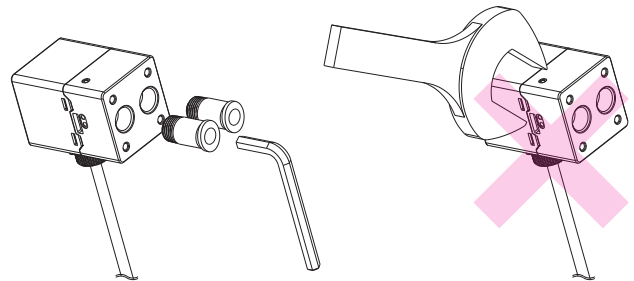

\* Internal Hex Straight Tube-to-Tube Adaptors are recommended.

## Output Circuit Wiring Diagrams

### KGS01- G - 02

1 NPN Output

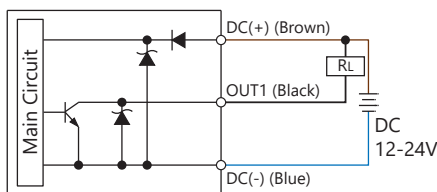

### KGS01- G - 04

1 PNP Output

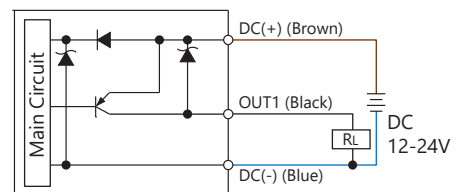

## Ordering Information

**K G S 0 1 - G - 0 2 - F 1 C**

### Rated Distance Range

G : 0.01 ~ 0.10 mm

### Output Specifications

02 : 1 NPN Output  
04 : 1 PNP Output

### Pressure Port

F1C : Rc1/8"

### Optional Parts

BT-18 : Mounting bracket  
BT-19 : Mounting bracket  
PA-E : Panel adapter  
PA-F : Panel adapter + Front protective lid

### Optional Parts

■ Mounting bracket : BT-18 / BT-19

■ Panel adapter : PA-E

■ Panel adapter + Front protective lid : PA-F



## Dimensions

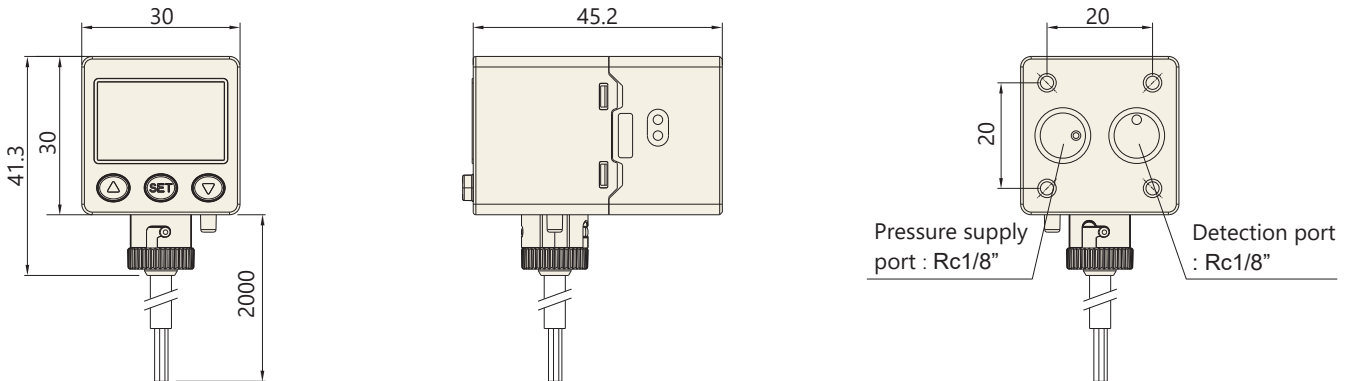

## Optional Parts Dimensions

### 1 Mounting Bracket

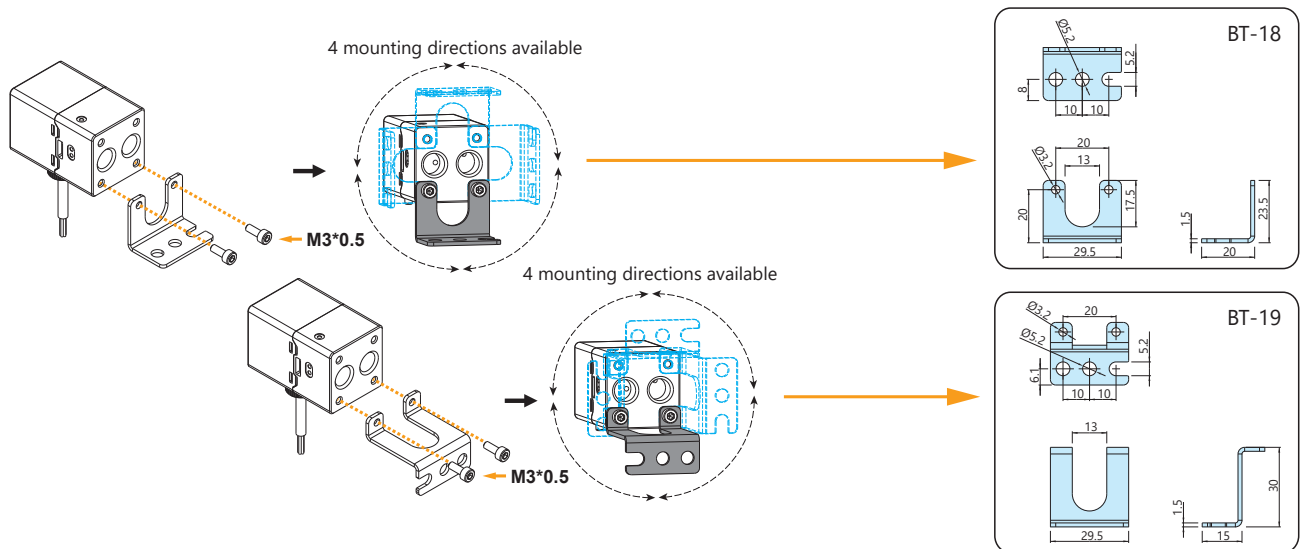

### 2 Panel Mount Adapter + Front Protective Lid

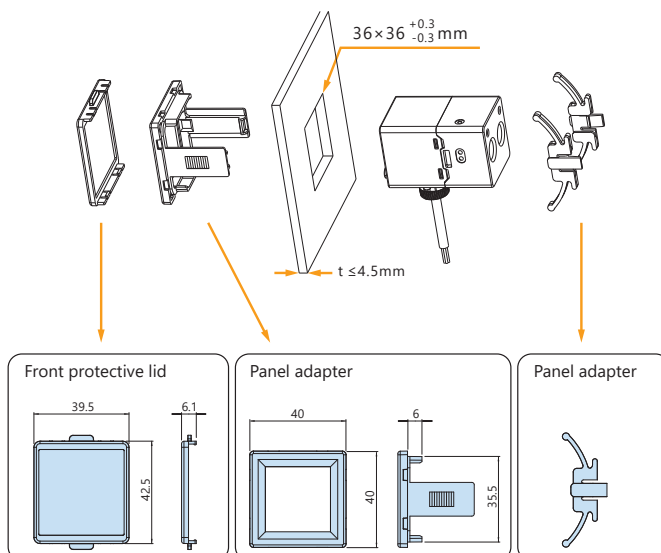

### 3 IP65 Protector

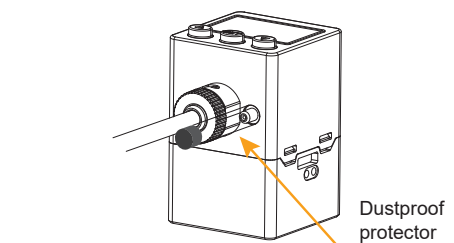

**Caution:**  
 This device must be installed to maintain IP 65  
 ( Dust and splash proof ) enclosure rating.

Unit : mm

# Magnetic Sensor

**KT-05 Series**



P.92

**KT-06 Series**



P.93

**KT-07 Series ★**



P.94

**KT-09 Series**



P.95

**KT-11 Series**



P.96

**KT-13 Series**



P.97

**KT-15 Series**



P.98

**KT-16 Series**



P.99

**KT-20 Series**



P.100

**KT-21 Series**



P.101

**KT-31 Series**  
High Temp. Resistant



P.102

**KT-32 Series**



P.103

**KT-32-EX Series**



P.104

**KT-33 Series**



P.105

**KT-36 Series**  
Compact Size



P.106

**KT-37 Series**  
Compact Size



P.107

**KT-38 Series**  
Compact Size



P.108

**KT-40 Series**



P.109

**KT-47 Series**



P.110

**KT-48 Series**



P.111

**KT-50 Series**  
Patented



P.112

**KT-53 Series**



P.113

**KT-58 Series**



P.114

**KT-59 Series**



P.115

**KT-65 Series ★**  
Patented



P.116

**KT-65-EX Series**  
Patented  
ATEX



P.117

**KT-65-UL Series**  
Patented  
UL US



P.118

**KT-71 Series**



P.119

**KT-75 Series**  
Patented



P.120

**KT-77 Series**



P.121

**KT-1000D Series**  
Magnetic-Field Resistant



P.122

**KT-1001D Series**  
Magnetic-Field Resistant



P.124

**Bracket**



P.125

**Clamp**



P.129

**Magnet**



P.135

## Ordering Information

K T - **06RH** - **1M**

Sensor Model

Sensor Type

R = Reed switch 2-wire type  
 RP = Reed switch 3-wire current sourcing  
 RN = Reed switch 3-wire current sinking  
 P = Solid state type, current sourcing (PNP output)  
 N = Solid state type, current sinking (NPN output)  
 D = Solid state type, 2-wire  
 T = TRIAC output  
 R - NC = REED / N. C  
 P - NC = PNP / N. C  
 N - NC = NPN / N. C

Special Mark

None = Standard sensitivity  
 H = High sensitivity  
 HH = Ultra high sensitivity  
 L = Low sensitivity  
 LL = Ultra low sensitivity  
 X = No indicator

Cable Length / QD Pinout

QD = M8 male connector  
 EQD = M8 male connector  
 1M = The length of cable is 1 meter  
 2M = The length of cable is 2 meters  
 3M = The length of cable is 3 meters  
 5M = The length of cable is 5 meters  
 10M = The length of cable is 10 meters

## Connection Method

### 1 2 Wire Sensor Connection

#### General Connection (Reed Switch)

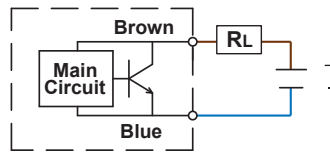
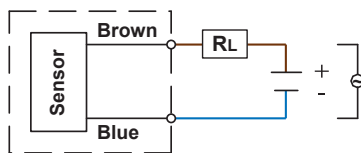

(PLC)

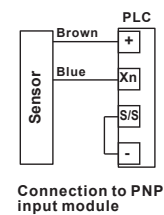
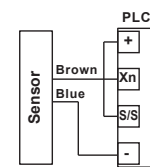

Connection to NPN input module

Connection to PNP input module

#### Series Connection (AND)

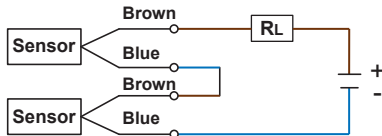

When connecting 2-wire sensors in series (AND), don't exceed more than two sensors due to the internal voltage drop (Typical V drop = 2.5 ~ 4 V per switch). Excessive Voltage drop will cause non-operation of the load.

#### Parallel Connection (OR)

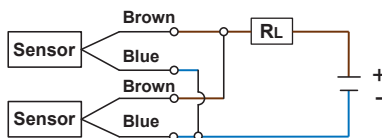

- When connecting solid state 2-wire sensors in parallel (OR), leakage current will increase and cause improper load operation.
- When connecting 2-wire reed sensors in parallel (OR), possible concurrent operation will cause dim LED illumination due to lower current distribution.

### 2 3 Wire NPN Connection

#### General Connection

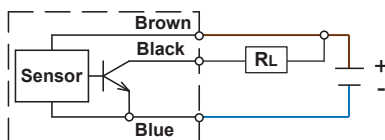

#### Series Connection (AND)

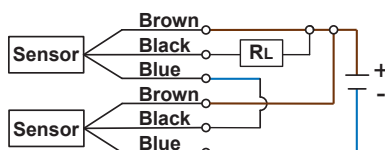

#### Parallel Connection (OR)

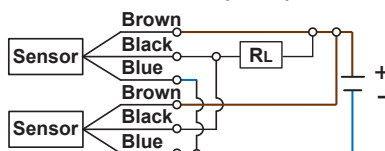



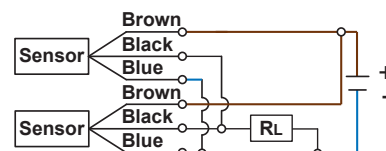
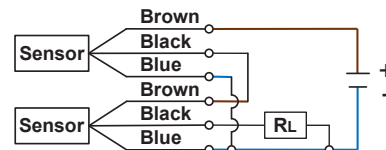
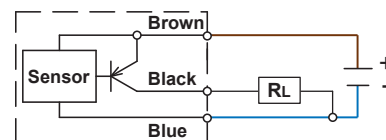









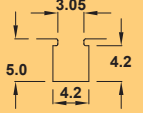

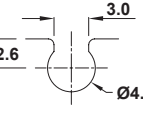

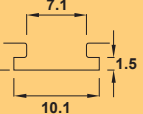

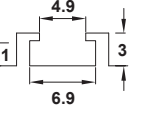

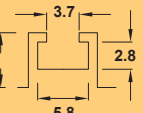

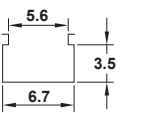
### 3 3 Wire PNP Connection

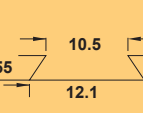

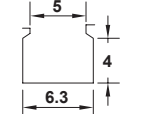
# Cylinder / Magnetic SW. Cross Index

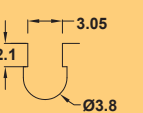

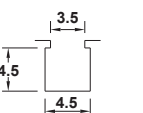
MODEL	KT-05	KT-06	KT-07	KT-09	KT-11	KT-13	KT-15	KT-16	KT-20	KT-21	KT-31	KT-32 KT-32-EX
<b>Round Cylinder</b> 	● BK Clamp P130		● BKC-1 Clamp P132				● BK Clamp P130		● PN / PH Clamp P129	● PN / PH Clamp P129		
<b>ISO Profile Cylinder</b> 			● PF7 Bracket P127					● PF7 Bracket P127	● PI Bracket P125	● PI Bracket P125	● PI Bracket P125	● PF Bracket P126
<b>Tie-Rod Cylinder</b> 			● DT7 Bracket P127	●		●		● DT7 Bracket P127	● PM Bracket P125	● PM Bracket P125	● PM Bracket P125	● DT Bracket P126 FST Clamp P134
 4 x 4 Solt 		●										
 SMC C Solt 			●					●				
 KOGANEI T Solt 					●							
 SMC T Solt 												
 SMC T Solt 												
 FESTO T Solt 			● PB Bracket P128					● PB Bracket P128				●
 Dovetail Solt 												
 SMC T Solt 			● PB Bracket P128					● PB Bracket P128				
 FESTO C Solt 												
 AIRTAC 4 x 4 Slot 												

\* Figures above are for reference only; sizes will vary according to individual cylinder manufacturer.



KT-33	KT-36	KT-37	KT-38	KT-40	KT-47	KT-48	KT-50	KT-53	KT-58	KT-59	KT-65 KT-65-EX KT-65-UL	KT-71	KT-75	KT-77	KT-1000D	KT-1001D
	BKC-1 Bracket P132			BL-1 Clamp P131		BS Clamp P130	BL-1 Clamp P131				BKT-1 Clamp P133		BKT-1 Clamp P133	BKC-1 Clamp P132	BP Clamp P123 PMB Bracket P123	
	PF7 Bracket P127	PF7 Bracket P127	PF7 Bracket P127	PF Bracket P126			PF Bracket P126				PF Bracket P126		PF Bracket P126	PF7 Bracket P127		
	DT7 Bracket P127	DT7 Bracket P127	DT7 Bracket P127	DT Bracket P126 FST Clamp P134			DT Bracket P126 FST Clamp P134				DT Bracket P126 FST Clamp P134		DT Bracket P126 FST Clamp P134	DT7 Bracket P127		
																PB Bracket P128
	PB Bracket P128	PB Bracket P128	PB Bracket P128											PB Bracket P128		PB Bracket P128

# Magnetic Sensor Operating & Installing

## Reed SW. Type

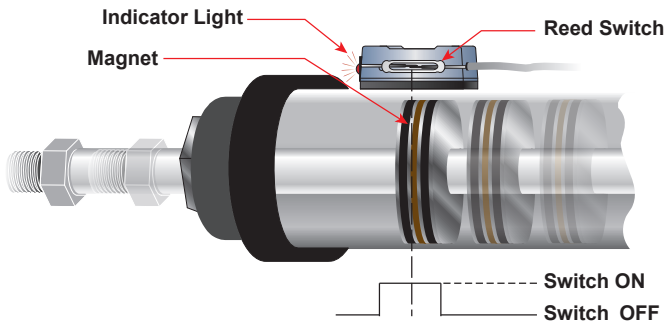

When the piston's magnet approaches the magnetic sensor, the internal reed switch will detect the change of magnetic field and close the contacts.

## Solid State Type

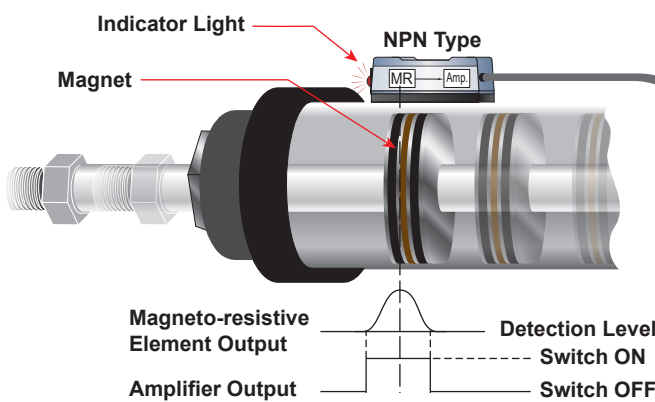

MODEL : TS-2

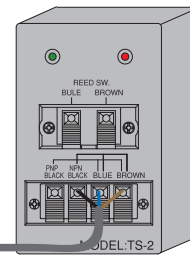

When the piston's magnet approaches the magnetic sensor, the internal magneto-resistive element can detect the change of magnetic field and cause a tiny voltage change. Switching output is achieved when this signal is amplified by the operation amplifier circuit in the magnetic sensor.

## How To Install The Magnetic Sensor

### 1 End Of Stroke Detection

- STEP 1 : Set the piston to the end of stroke position.

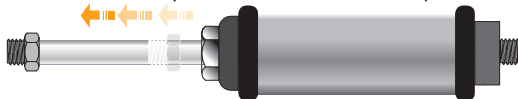

- STEP 2 : Slide the magnetic sensor forward and keep it close to the cylinder wall. Make a mark at the sensor turn-on point.



- STEP 3 : Slide the sensor forward continuously until the sensor turns off.

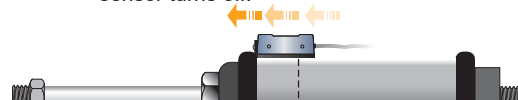

- STEP 4 : Slide the sensor backward until the sensor turns back on and make a mark.



- STEP 5 : The intermediate position between the 2 marks will be the most ideal position.

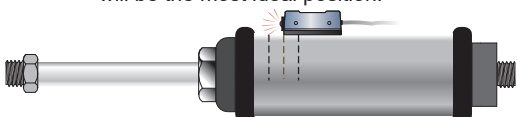

### 2 Intermediate Stroke Position

- STEP 1 : Set the piston to the required position.



- STEP 2 : Slide the magnetic sensor forward and keep it close to the cylinder wall. Make a mark at the sensor turn-on point.

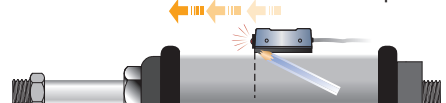

- STEP 3 : Slide the sensor forward continuously until the sensor turns off.

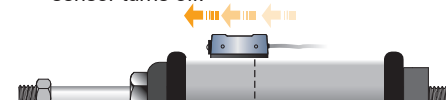

- STEP 4 : Slide the sensor backward until the sensor turns back on and make a mark.

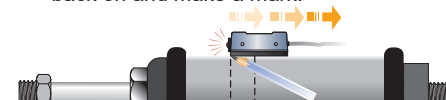

- STEP 5 : The intermediate position between the 2 marks will be the most ideal position.

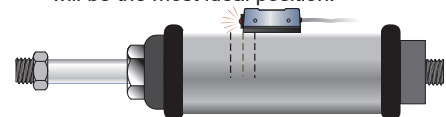

# Caution

**1** Do not exceed specification, permanent damage to the sensor may occur.

**2** For reed sensor type sensors, polarity must also be observed for the proper function of LED. Connect the brown wire in series with load to positive ( + ) and the blue wire to negative ( - ) of power source. If the polarity is reversed, reed sensor remain functional but LED will remain in " OFF " state.

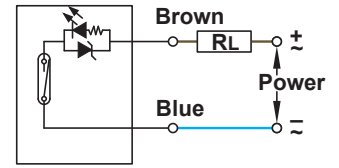

**3** For solid-state type sensors, polarity must also be observed. Connect brown wire to the positive ( + ) and the blue to the negative ( - ) of DC power source. The black wire must connect to the load only. If the black wire is accidentally connected to the power source, permanent damage to the sensor may occur.

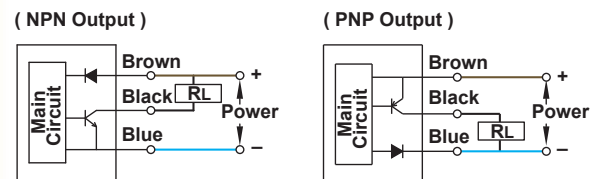

**4** An external protection circuit may be required if the magnetic sensor is used with inductive load, such as relay or solenoid. For DC inductive load, attach an external diode parallel to the load and use R-C circuit parallel with AC inductive load as illustrated below.

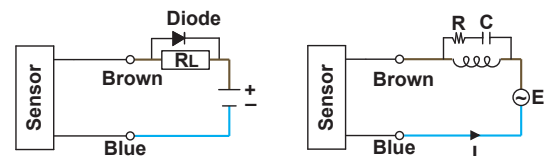

$$C = I^2 / 10 \text{ [}\mu\text{F]}$$

$$R = E / 10 I (1 + 50/E) \text{ [}\Omega\text{]}$$

PS:  
C:Capacitor    I :Load current  
R:Resistance    E:AC power

**5** Keep sensors away from strong magnetic field to prevent malfunctions.

**6** There is no circuit protection for reed switch.

- Using with an inductive load.
- The wiring length to the load is more than 5 m.
- Load voltage is 100 / 200 AC V.

For any of the above cases, the contact life may be shortened. ( especially maintained in a normally ON state ).  
Note: Please installed a surge suppressor SR-1 or in series an inductor ( 560 ~ 1000 uH ) with the sensor that ensure the sensor is operational.

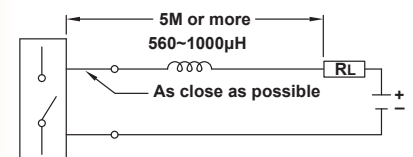

■ **MODEL : SR-1 ( Surge Suppressor )**

■ **Dimension**

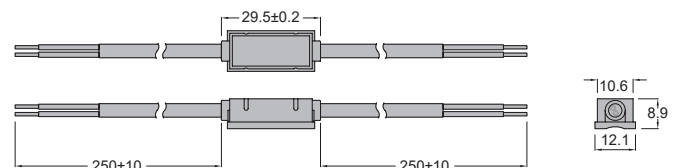
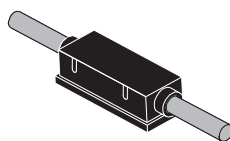
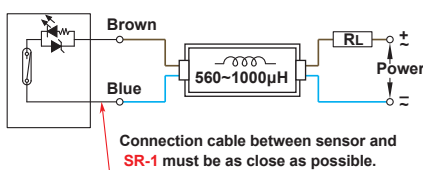

Unit : mm

# Hot Sale

## Product Integration

### KT-07 & KT-16 Series

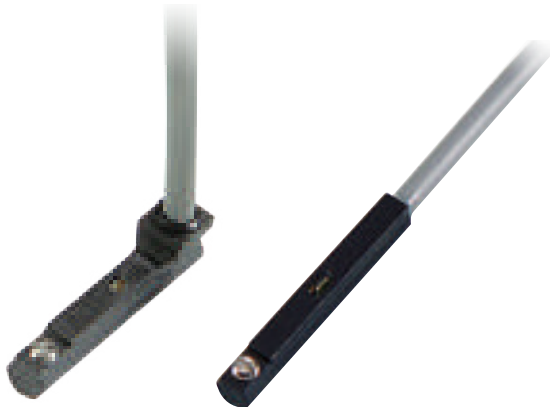

- Fits in most C-slot cylinder, replace all other T-slot sensors, and reducing your inventory.

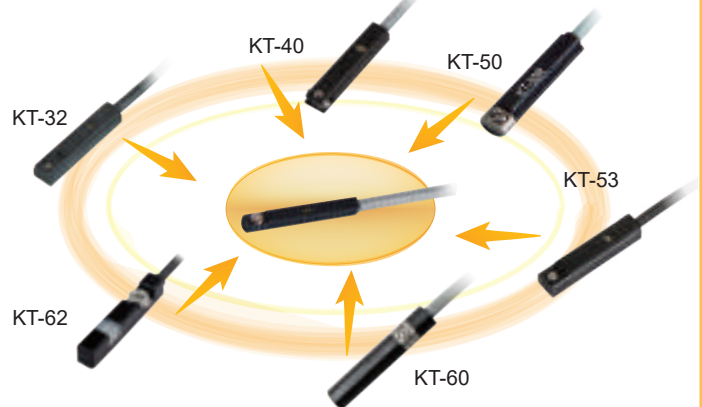

## Common Cylinder Slot Dimensions

### ※ C-slot cylinder dimensions

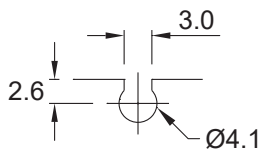

### ※ T-slot cylinder dimensions

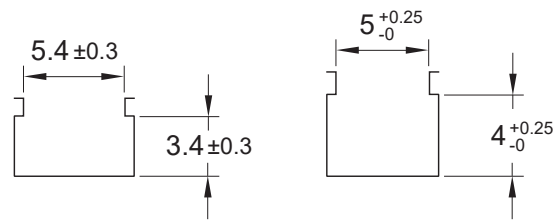

## Mounting Adapter for Other Cylinder Types

- Applied to many kind of cylinders.

### PF7 bracket mount with ISO profile cylinder



P.127

### BKC-1 clamp mount with round cylinder

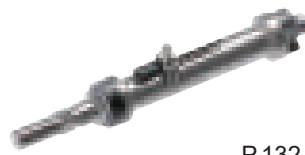

P.132

### C-slot cylinder



KT-07 P.94  
KT-16 P.99

### DT7 bracket mount with Tie-Rod cylinder

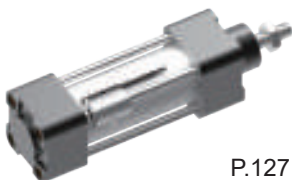

P.127

### PB bracket mount with T-slot cylinder



P.128

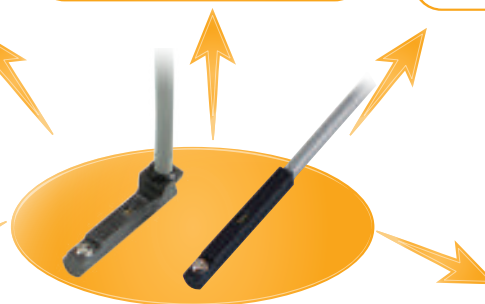

KT-07 & KT-16 Series

## New Structure

- **KT-65 & KT-75 Series**
- Set-screw near center position to prevent sensor from moving, combined with new set-screw design to provide solid stance when attached to the cylinder.

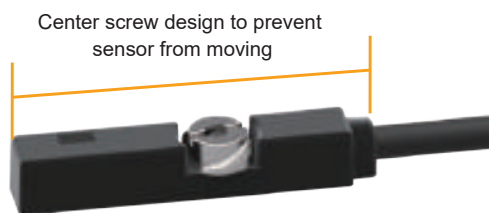

- Fits in most T-slot, replace all other T-slot sensors, reducing inventory items.

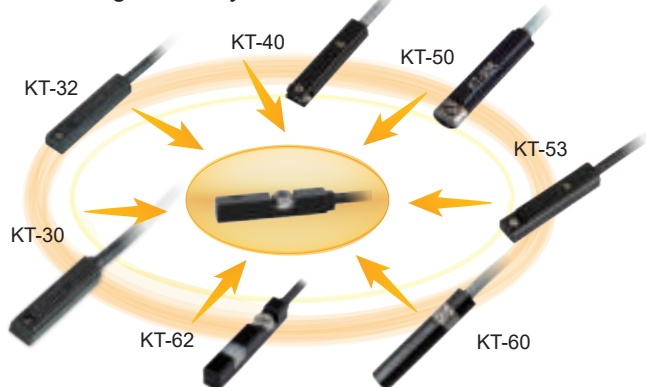

## Quick Installation

- Install sensor from top of cylinder, directly placed into T-slot to achieve quick installation.

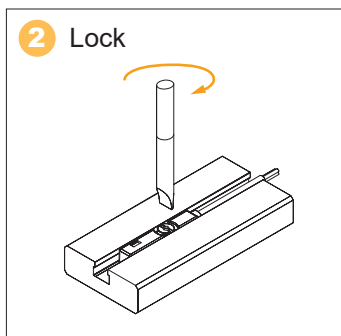
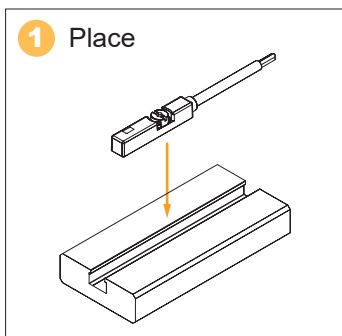

### ※ T-slot cylinder dimensions

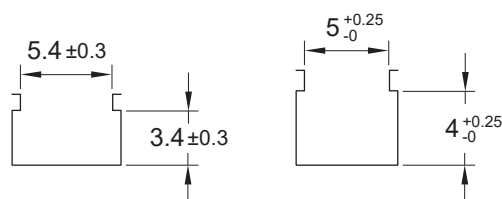

## Mounting Adapter for Other Cylinder Types

- Applied to many kind of cylinders.

PF bracket mount with ISO profile cylinder



FST clamp mount with Tie-Rod cylinder



BKT-1 clamp mount with round cylinder

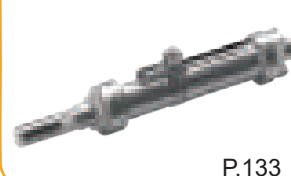

DT bracket mount with Tie-Rod cylinder



T-slot cylinder



KT-65 & KT-75 Series

# KT-05 SERIES



## Dimensions

KT-05R, KT-05D, KT-05DE, KT-05N, KT-05NE,  
KT-05P, KT-05PE /  
KT-05R-QD, KT-05D-QD, KT-05DE-QD,  
KT-05N-QD, KT-05NE-QD, KT-05P-QD, KT-05PE-QD

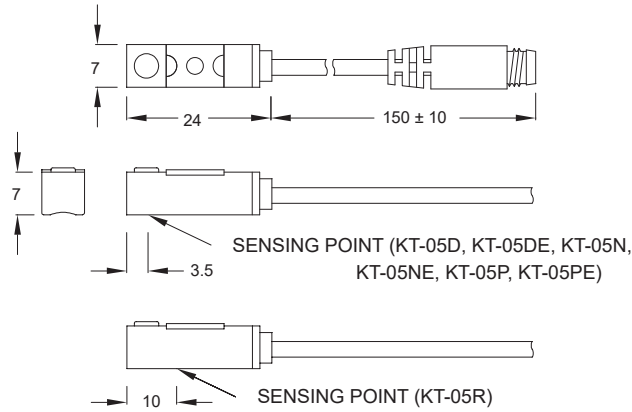

Unit : mm

## QD Pinout

### 3 wire QD wiring

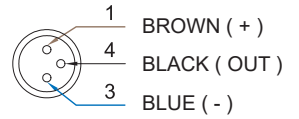

### 2 wire QD wiring

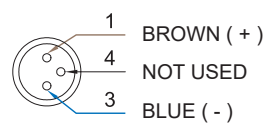

### 2 wire EQD wiring

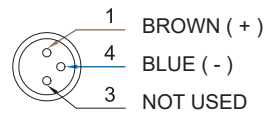

## Specifications

MODEL	KT-05R	KT-05D	KT-05DE	KT-05N	KT-05NE	KT-05P	KT-05PE
<b>Connect Diagram</b>							
<b>Characteristics</b>	2-Wire type			3-Wire type			
<b>Wiring Method</b>	2-Wire type			3-Wire type			
<b>Switching Logic</b>	SPST, Normally Open	-		Solid State Output, Normally Open			
<b>Sensor Type</b>	Reed Switch	-		NPN Current Sinking		PNP Current Sourcing	
<b>Operating Voltage</b>	5 ~ 240 V DC / AC	10 ~ 28 V DC		5 ~ 30 V DC			
<b>Switching Current</b>	100 mA max.	50 mA max.		200 mA max.			
<b>Contact Rating *1</b>	10 W max.	1.5 W max.		6 W max.			
<b>Current Consumption</b>	-			8 mA @ 24 V DC max.	6 mA @ 24 V DC max.	8 mA @ 24 V DC max.	6 mA @ 24 V DC max.
<b>Voltage Drop</b>	3.5 V max.		3.7 V max.	1 V @ 200 mA max.	0.5 V @ 200 mA max.	1 V @ 200 mA max.	0.5 V @ 200 mA max.
<b>Leakage Current</b>	-	0.8 mA max.	0.1 mA (40 uA) max.	0.01 mA max.			
<b>Indicator</b>	Red LED					Green LED	
<b>Cable</b>	Ø2.8, 2C, PVC			Ø2.8, 3C, PVC			
<b>Operating Frequency</b>	200 Hz	1000 Hz max.					
<b>Magnet Requirement *2</b>	55 Gauss	80 Gauss	40 ~ 1000 Gauss	80 Gauss	40 ~ 1000 Gauss	80 Gauss	40 ~ 1000 Gauss
<b>Temperature Range</b>	-10 ~ 70 °C						
<b>Shock *3</b>	30 G	50 G					
<b>Vibration *4</b>	9 G						
<b>Enclosure Classification</b>	IEC 60529 IP67						
<b>Protection Circuit *5</b>	1	2, 4	3, 4	2, 3, 4	3, 4	2, 3, 4	3, 4

### NOTE:

\*1 : WARNING : Never exceed rating ( Watt = Voltage x Amperage ).  
Permanent damage to sensor will occur.

\*2 : Measuring standard target : ø15.5 × ø8 × 5t ( Anisotropy rubber magnet )

\*3 : Sin wave / X , Y , Z 3 directions / 3 times each direction / 11 ms each time.

\*4 : Double amplitude 1.5 mm / 10 Hz ~ 55 Hz ~ 10 Hz ( Sweep 1 min ) / X , Y , Z 3 directions / 1 hour each time.

\*5 : 1 = None / 2 = Short-circuit / 3 = Power Source Reverse polarity / 4 = Surge Suppression

## Clamps

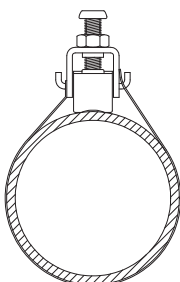

### BK Series

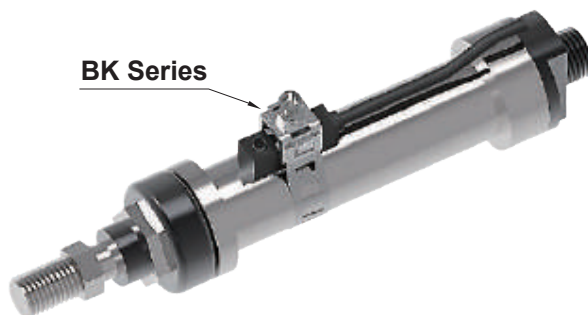

# KT-06 SERIES



## Dimensions

KT-06R, KT-062R, KT-06D, KT-06DE, KT-06N, KT-06NE, KT-06P, KT-06PE / KT-06R-QD, KT-062R-QD, KT-06D-QD, KT-06DE-QD, KT-06N-QD, KT-06NE-QD, KT-06P-QD, KT-06PE-QD

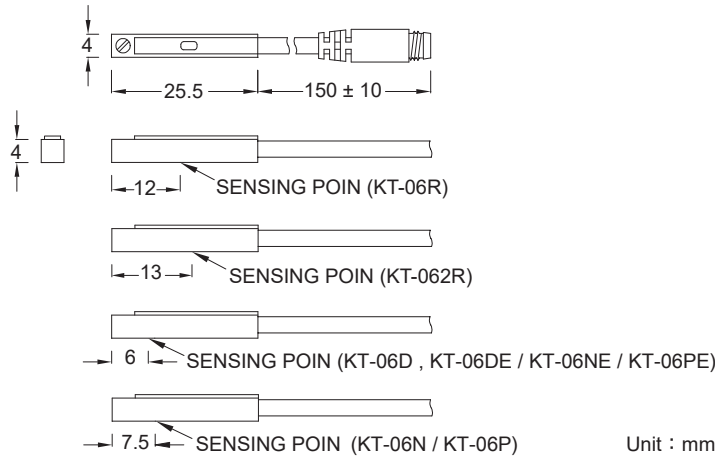

Unit : mm

## QD Pinout

### 3 wire QD wiring

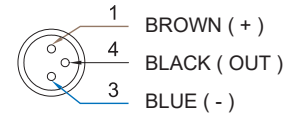

### 2 wire QD wiring

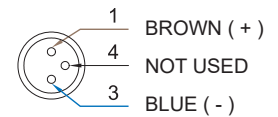

### 2 wire EQD wiring

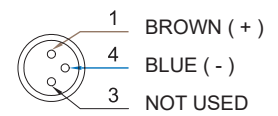

## Specifications

MODEL	KT-06R	KT-062R	KT-06D	KT-06DE	KT-06N	KT-06NE	KT-06P	KT-06PE
Connect Diagram								
Characteristics								
Wiring Method	2-Wire Type				3-Wire Type			
Switching Logic	SPST, Normally Open			Solid State Output, Normally Open				
Sensor Type	Reed Switch		-		NPN Current Sinking		PNP Current Sourcing	
Operating Voltage	5 ~ 120 V DC / AC	5 ~ 240 V DC / AC	10 ~ 28 V DC	5 ~ 30 V DC				
Switching Current	100 mA max.		4 ~ 40 mA max.	50 mA max.	200 mA max.			
Contact Rating *1	10 W max.		1.1 W max.	1.5 W max.	6 W max.			
Current Consumption	-		-		8 mA @ 24 VDC max.	6 mA @ 24 VDC max.	8 mA @ 24 VDC max.	6 mA @ 24 VDC max.
Voltage Drop	3.5 V max.			3.7 V max.	1 V @ 200 mA max.	0.5 V @ 200 mA max.	1 V @ 200 mA max.	0.5 V @ 200 mA max.
Leakage Current	-		1 mA max.	0.1 mA (40 uA) max.	0.01 mA max.			
Indicator	Red LED	Green LED	Red LED				Green LED	
Cable	Ø2.8, 2C, PUR				Ø2.8, 3C, PUR			
Operating Frequency	200 Hz		1000 Hz max.					
Magnet Requirement *2	70 Gauss		40 Gauss	40 ~ 1000 Gauss	40 Gauss	40 ~ 1000 Gauss	40 Gauss	40 ~ 1000 Gauss
Temperature Range	-10 ~ 70 °C							
Shock *3	30 G		50 G					
Vibration *4	9 G							
Enclosure Classification	IEC 60529 IP67							
Protection Circuit *5	1		4	3, 4	2, 3, 4	3, 4	2, 3, 4	3, 4

### NOTE:

\*1 : WARNING : Never exceed rating ( Watt = Voltage x Amperage ). Permanent damage to sensor will occur.

\*2 : Measuring standard target : ø15.5 × ø8 × 5t ( Anisotropy rubber magnet )

\*3 : Sin wave / X , Y , Z 3 directions / 3 times each direction / 11 ms each time.

\*4 : Double amplitude 1.5 mm / 10 Hz ~ 55 Hz ~ 10 Hz ( Sweep 1 min ) / X , Y , Z 3 directions / 1 hour each time.

\*5 : 1 = None / 2 = Short-circuit / 3 = Power Source Reverse polarity / 4 = Surge Suppression

## Groove Dimensions

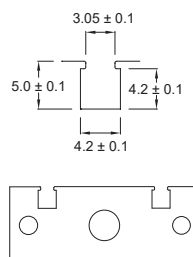

Unit : mm

# KT-07 SERIES



## Dimensions

KT-07R, KT-072R, KT-07D, KT-07DE, KT-07N, KT-07NE,  
KT-07P, KT-07PE /  
KT-07R-QD, KT-072R-QD, KT-07D-QD, KT-07DE-QD,  
KT-07N-QD, KT-07NE-QD, KT-07P-QD, KT-07PE-QD

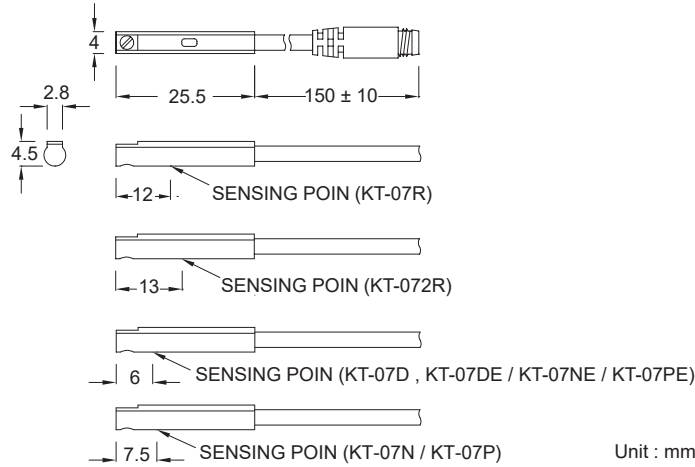

Unit : mm

## QD Pinout

### 3 wire QD wiring

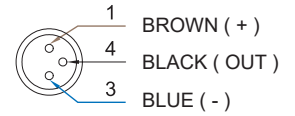

### 2 wire QD wiring

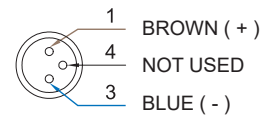

### 2 wire EQD wiring

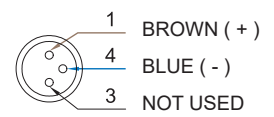

## Specifications

MODEL	KT-07R	KT-072R	KT-07D	KT-07DE	KT-07N	KT-07NE	KT-07P	KT-07PE
<b>Connect Diagram</b>								
<b>Characteristics</b>	Reed Switch		-		NPN Current Sinking		PNP Current Sourcing	
<b>Wiring Method</b>	2-Wire Type				3-Wire Type			
<b>Switching Logic</b>	SPST, Normally Open				Solid State Output, Normally Open			
<b>Operating Voltage</b>	5 ~ 120 V DC / AC	5 ~ 240 V DC / AC	10 ~ 28 V DC		5 ~ 30 V DC			
<b>Switching Current</b>	100 mA max.		4 ~ 40 mA max.	50 mA max.	200 mA max.			
<b>Contact Rating *1</b>	10 W max.		1.1 W max.	1.5 W max.	6 W max.			
<b>Current Consumption</b>	-				8 mA @ 24 V DC max.	6 mA @ 24 V DC max.	8 mA @ 24 V DC max.	6 mA @ 24 V DC max.
<b>Voltage Drop</b>	3.5 V max.			3.7 V max.	1 V @ 200 mA max.	0.5 V @ 200 mA max.	1 V @ 200 mA max.	0.5 V @ 200 mA max.
<b>Leakage Current</b>	-		1 mA max.	0.1 mA (40 uA) max.	0.01 mA max.			
<b>Indicator</b>	Red LED	Green LED	Red LED				Green LED	
<b>Cable</b>	Ø2.8, 2C, PUR				Ø2.8, 3C, PUR			
<b>Operating Frequency</b>	200 Hz		1000 Hz max.					
<b>Magnet Requirement *2</b>	70 Gauss		40 Gauss	40 ~ 1000 Gauss	40 Gauss	40 ~ 1000 Gauss	40 Gauss	40 ~ 1000 Gauss
<b>Temperature Range</b>	-10 ~ 70 °C							
<b>Shock *3</b>	30 G		50 G					
<b>Vibration *4</b>	9 G							
<b>Enclosure Classification</b>	IEC 60529 IP67							
<b>Protection Circuit *5</b>	1		4	3, 4	2, 3, 4	3, 4	2, 3, 4	3, 4

### NOTE:

\*1 : WARNING : Never exceed rating ( Watt = Voltage x Amperage ).  
Permanent damage to sensor will occur.

\*2 : Measuring standard target : ø15.5 × ø8 × 5t ( Anisotropy rubber magnet )

\*3 : Sin wave / X , Y , Z 3 directions / 3 times each direction / 11 ms each time.

\*4 : Double amplitude 1.5 mm / 10 Hz ~ 55 Hz ~ 10 Hz ( Sweep 1 min ) / X , Y , Z 3 directions / 1 hour each time.

\*5 : 1 = None / 2 = Short-circuit / 3 = Power Source Reverse polarity / 4 = Surge Suppression

## Groove Dimensions

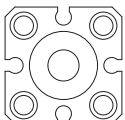
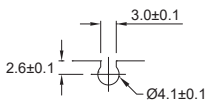

## Bracket

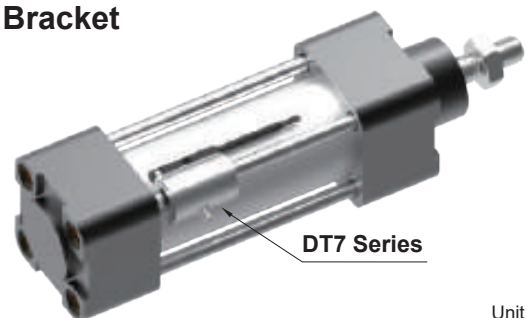

DT7 Series

Unit : mm

# KT-09 SERIES



## Dimensions

KT-09R, KT-09N, KT-09P /  
KT-09R-QD, KT-09N-QD, KT-09P-QD

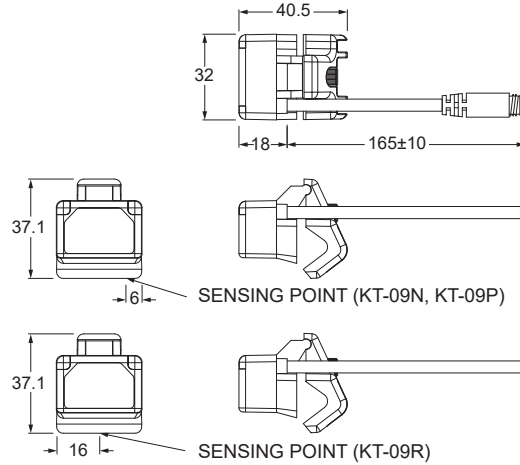

## QD Pinout

- 3 wire QD wiring
  - 1 BROWN (+)
  - 4 BLACK (OUT)
  - 3 BLUE (-)
- 2 wire QD wiring
  - 1 BROWN (+)
  - 4 NOT USED
  - 3 BLUE (-)
- 2 wire EQD wiring
  - 1 BROWN (+)
  - 4 BLUE (-)
  - 3 NOT USED

Unit : mm

## Specifications

MODEL	KT-09R	KT-09N	KT-09P
<b>Connect Diagram</b>			
<b>Characteristics</b>			
<b>Wiring Method</b>	2-Wire Type	3-Wire Type	
<b>Switching Logic</b>	SPST, Normally Open	Solid State Output, Normally Open	
<b>Sensor Type</b>	Reed Switch	NPN Current Sinking	PNP Current Sourcing
<b>Operating Voltage</b>	5 ~ 240 V DC / AC	5 ~ 30 V DC	
<b>Switching Current</b>	1 Amp. max.		
<b>Contact Rating *1</b>	30 W max.		
<b>Current Consumption</b>	-	42 mA @ 24 V DC max.	30 mA @ 24 V DC max.
<b>Voltage Drop</b>	3.5 V max.	1.5 V @ 0.5 A max.	
<b>Leakage Current</b>	-	0.01 mA max.	
<b>Indicator</b>	Red LED	Power : Green LED , Output : Red LED	
<b>Cable</b>	ø4.5, 2C, PVC	ø4.5, 3C, PVC	
<b>Operating Frequency</b>	200 Hz	1000 Hz	
<b>Magnet Requirement *2</b>	80 Gauss	40 Gauss	
<b>Temperature Range</b>	-10 ~ 70 °C		
<b>Shock *3</b>	30 G	50G	
<b>Vibration *4</b>	9 G		
<b>Enclosure Classification</b>	IEC 60529 IP67		
<b>Protection Circuit *5</b>	4	3, 4	

**NOTE:**

\*1 : WARNING : Never exceed rating ( Watt = Voltage x Amperage ).  
Permanent damage to sensor will occur.

\*2 : Measuring standard target : ø15.5 × ø8 × 5t ( Anisotropy rubber magnet )

\*3 : Sin wave / X , Y , Z 3 directions / 3 times each direction / 11 ms each time.

\*4 : Double amplitude 1.5 mm / 10 Hz ~ 55 Hz ~ 10 Hz ( Sweep 1 min ) / X , Y , Z 3 directions / 1 hour each time.

\*5 : 1 = None / 2 = Short-circuit / 3 = Power Source Reverse polarity / 4 = Surge Suppression

## Clamps

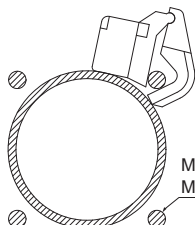

Unit : mm

# KT-11 SERIES



## Dimensions

KT-11R, KT-11D, KT-11DE, KT-11N, KT-11NE, KT-11P, KT-11PE /  
KT-11R-QD, KT-11D-QD, KT-11DE-QD, KT-11N-QD, KT-11NE-QD,  
KT-11P-QD, KT-11PE-QD

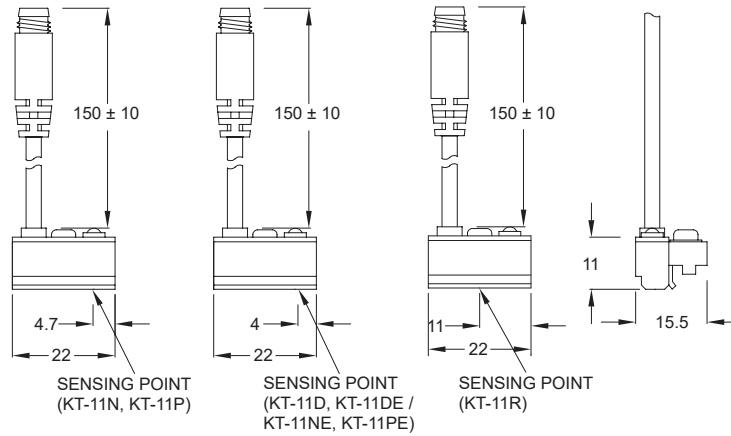

## QD Pinout

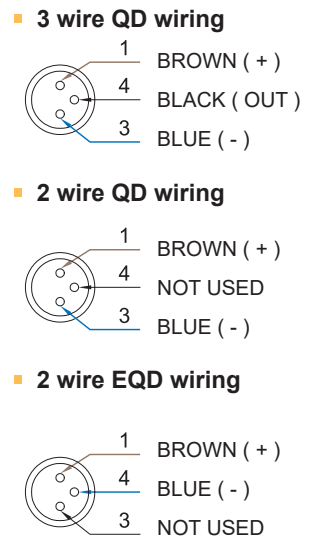

Unit : mm

## Specifications

MODEL	KT-11R	KT-11D	KT-11DE	KT-11N	KT-11NE	KT-11P	KT-11PE
<b>Connect Diagram</b>							
<b>Characteristics</b>	2-Wire type			3-Wire type			
<b>Wiring Method</b>	2-Wire type			3-Wire type			
<b>Switching Logic</b>	SPST, Normally Open	-		Solid State Output, Normally Open			
<b>Sensor Type</b>	Reed Switch	-		NPN Current Sinking		PNP Current Sourcing	
<b>Operating Voltage</b>	5 ~ 240 V DC / AC	10 ~ 28 V DC	5 ~ 30 V DC				
<b>Switching Current</b>	100 mA max.	4 ~ 40 mA max.	50 mA max.	200 mA max.			
<b>Contact Rating *1</b>	10 W max.	1.1 W max.	1.5 W max.	6 W max.			
<b>Current Consumption</b>	-			22 mA @ 24 V DC max.	6 mA @ 24 V DC max.	20 mA @ 24 V DC max.	6 mA @ 24 V DC max.
<b>Voltage Drop</b>	3.5 V max.		3.7 V max.	0.5 V @ 200 mA max.			
<b>Leakage Current</b>	-	1 mA max.	0.1 mA (40 uA) max.	0.01 mA max.			
<b>Indicator</b>	Red LED	Green LED		Red LED		Green LED	
<b>Cable</b>	ø3.3, 2C, PVC			ø3.3, 3C, PVC			
<b>Operating Frequency</b>	200 Hz	1000 Hz max.					
<b>Magnet Requirement *2</b>	70 Gauss	60 Gauss	40 ~ 1000 Gauss	60 Gauss	40 ~ 1000 Gauss	60 Gauss	40 ~ 1000 Gauss
<b>Temperature Range</b>	-10 ~ 70 °C						
<b>Shock *3</b>	30 G	50 G					
<b>Vibration *4</b>	9 G						
<b>Enclosure Classification</b>	IEC 60529 IP67						
<b>Protection Circuit *5</b>	1	4	3, 4				

### NOTE:

\*1 : WARNING : Never exceed rating ( Watt = Voltage x Amperage ).  
Permanent damage to sensor will occur.

\*2 : Measuring standard target : ø15.5 × ø8 × 5t ( Anisotropy rubber magnet )

\*3 : Sin wave / X , Y , Z 3 directions / 3 times each direction / 11 ms each time.

\*4 : Double amplitude 1.5 mm / 10 Hz ~ 55 Hz ~ 10 Hz ( Sweep 1 min ) / X , Y , Z 3 directions / 1 hour each time.

\*5 : 1 = None / 2 = Short-circuit / 3 = Power Source Reverse polarity / 4 = Surge Suppression

## Groove Dimensions

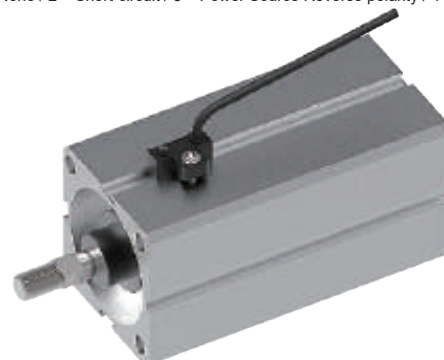
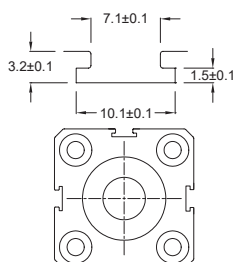

Unit : mm

# KT-13 SERIES



## Dimensions

KT-13R, KT-13DE, KT-13NE, KT-13PE /  
KT-13R-QD, KT-13DE-QD, KT-13NE-QD, KT-13PE-QD

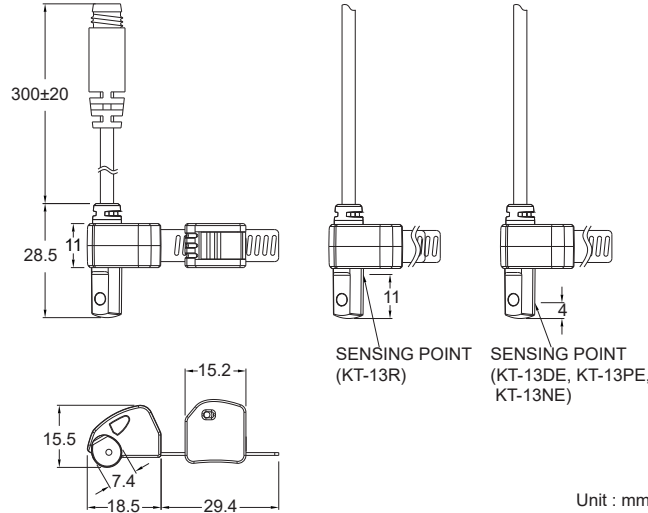

Unit : mm

## QD Pinout

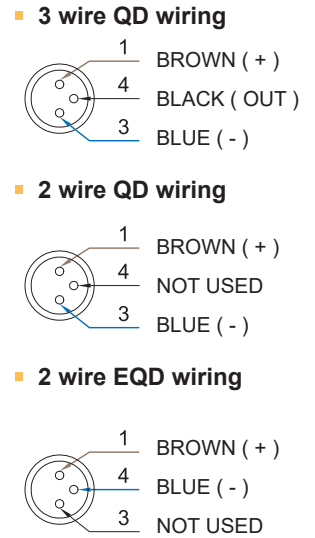

## Specifications

MODEL	KT-13R	KT-13DE	KT-13NE	KT-13PE
<b>Connect Diagram</b>				
<b>Characteristics</b>				
<b>Wiring Method</b>	2-Wire Type		3-Wire Type	
<b>Switching Logic</b>	SPST, Normally Open		Solid State Output, Normally Open	
<b>Sensor Type</b>	Reed Switch	-	NPN Current Sinking	PNP Current Sourcing
<b>Operating Voltage</b>	5 ~ 240 V DC / AC		5 ~ 30 V DC	
<b>Switching Current</b>	100 mA max.	50 mA max.	200 mA max.	
<b>Contact Rating *1</b>	10 W max.	1.5 W max.	6 W max.	
<b>Current Consumption</b>	-		6 mA @ 24 V DC max.	
<b>Voltage Drop</b>	3.5 V max.	3.7 V max.	0.5 V @ 200 mA max.	
<b>Leakage Current</b>	-	0.1 mA ( 40 uA ) max.	0.01 mA max.	
<b>Indicator</b>	Red LED			Green LED
<b>Cable</b>	ø3.3, 2C, PVC		ø3.3, 3C, PVC	
<b>Operating Frequency</b>	200 Hz	1000 Hz max.		
<b>Magnet Requirement *2</b>	55 Gauss	40 ~ 1000 Gauss		
<b>Temperature Range</b>	-10 ~ 70 °C			
<b>Shock *3</b>	30 G	50 G		
<b>Vibration *4</b>	9 G			
<b>Enclosure Classification</b>	IEC 60529 IP67			
<b>Protection Circuit *5</b>	1	3, 4		

### NOTE:

\*1 : WARNING : Never exceed rating ( Watt = Voltage x Amperage ).  
Permanent damage to sensor will occur.

\*2 : Measuring standard target : ø15.5 × ø8 × 5t ( Anisotropy rubber magnet )

\*3 : Sin wave / X , Y , Z 3 directions / 3 times each direction / 11 ms each time.

\*4 : Double amplitude 1.5 mm / 10 Hz ~ 55 Hz ~ 10 Hz ( Sweep 1 min ) / X , Y , Z 3 directions / 1 hour each time.

\*5 : 1 = None / 2 = Short-circuit / 3 = Power Source Reverse polarity / 4 = Surge Suppression

## Clamps

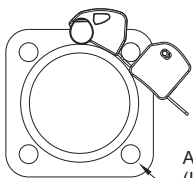

Applicable rod diameter Ø6 ~ Ø16  
(Using ISO Tie-Rod cylinder range Ø32 ~ Ø200)



Hex key Size : 2 mm

Unit : mm

# KT-15 SERIES



## Dimensions

KT-15R, KT-15N, KT-15P /  
KT-15R-QD, KT-15N-QD, KT-15P-QD

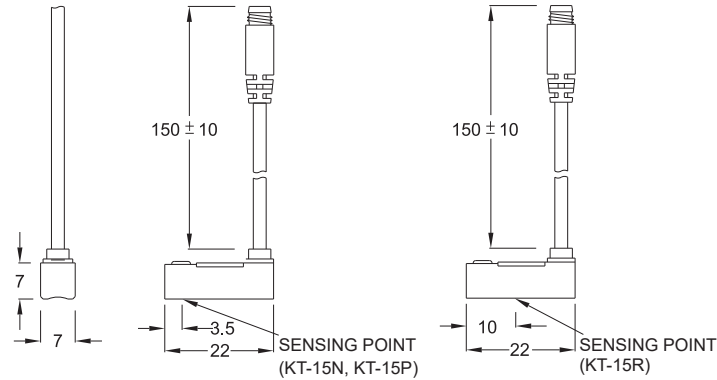

Unit : mm

## QD Pinout

### 3 wire QD wiring

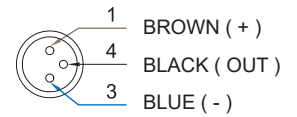

### 2 wire QD wiring

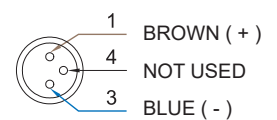

### 2 wire EQD wiring

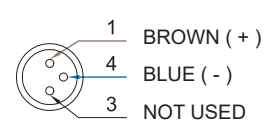

## Specifications

MODEL	KT-15R	KT-15N	KT-15P
<b>Connect Diagram</b>			
<b>Characteristics</b>			
<b>Wiring Method</b>	2-Wire Type	3-Wire Type	
<b>Switching Logic</b>	SPST, Normally Open	Solid State Output, Normally Open	
<b>Sensor Type</b>	Reed Switch	NPN Current Sinking	PNP Current Sourcing
<b>Operating Voltage</b>	5 ~ 240 V DC / AC	5 ~ 30 V DC	
<b>Switching Current</b>	100 mA max.	200 mA max.	
<b>Contact Rating *1</b>	10 W max.	6 W max.	
<b>Current Consumption</b>	-	20 mA @ 24 V DC max.	
<b>Voltage Drop</b>	3.5 V max.	0.5 V max.	
<b>Leakage Current</b>	-	0.01 mA max.	
<b>Indicator</b>	Red LED		Green LED
<b>Cable</b>	ø2.8, 2C, PVC	ø2.8, 3C, PVC	
<b>Operating Frequency</b>	200 Hz	1000 Hz	
<b>Magnet Requirement *2</b>	50 Gauss	40 Gauss	
<b>Temperature Range</b>	-10 ~ 70 °C		
<b>Shock *3</b>	30 G	50 G	
<b>Vibration *4</b>	9 G		
<b>Enclosure Classification</b>	IEC 60529 IP67		
<b>Protection Circuit *5</b>	1	3, 4	

### NOTE:

\*1 : WARNING : Never exceed rating ( Watt = Voltage x Amperage ).  
Permanent damage to sensor will occur.

\*2 : Measuring standard target : ø15.5 × ø8 × 5t ( Anisotropy rubber magnet )

\*3 : Sin wave / X , Y , Z 3 directions / 3 times each direction / 11 ms each time.

\*4 : Double amplitude 1.5 mm / 10 Hz ~ 55 Hz ~ 10 Hz ( Sweep 1 min ) / X , Y , Z 3 directions / 1 hour each time.

\*5 : 1 = None / 2 = Short-circuit / 3 = Power Source Reverse polarity / 4 = Surge Suppression

## Clamps

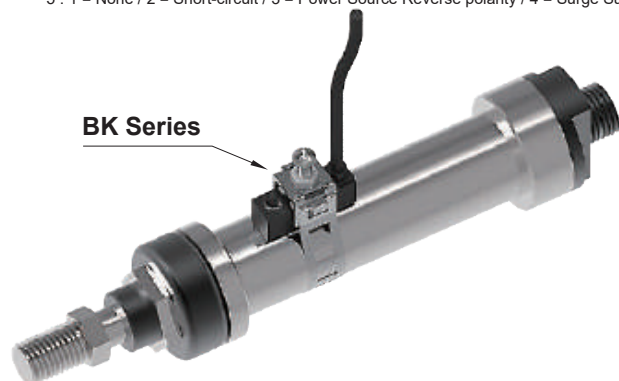
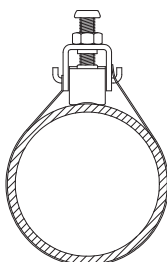

# KT-16 SERIES



### Dimensions

KT-16R, KT-16N, KT-16P /  
KT-16R-QD, KT-16N-QD, KT-16P-QD

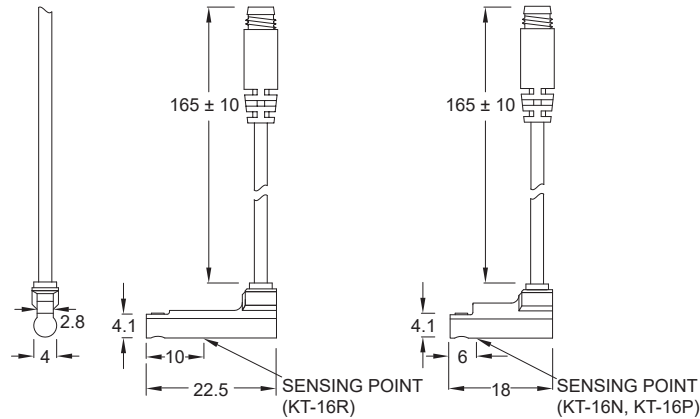

Unit : mm

### QD Pinout

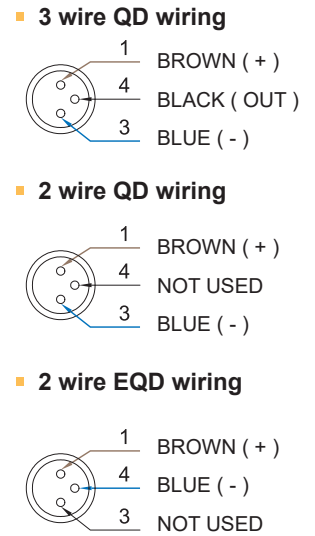

### Specifications

MODEL	KT-16R	KT-16N	KT-16P
<b>Connect Diagram</b>			
<b>Characteristics</b>			
<b>Wiring Method</b>	2-Wire Type	3-Wire Type	
<b>Switching Logic</b>	SPST, Normally Open	Solid State Output, Normally Open	
<b>Sensor Type</b>	Reed Switch	NPN Current Sinking	PNP Current Sourcing
<b>Operating Voltage</b>	5 ~ 120 V DC / AC	5 ~ 30 V DC	
<b>Switching Current</b>	100 mA max.	50 mA max.	
<b>Contact Rating *1</b>	6 W max.	1.5 W max.	
<b>Current Consumption</b>	-	7 mA @ 24 V DC max.	9 mA @ 24 V DC max.
<b>Voltage Drop</b>	3.5 V max.	1.5 V @ 50 mA max.	
<b>Leakage Current</b>	-	0.01 mA max.	
<b>Indicator</b>	Red LED		Green LED
<b>Cable</b>	ø2.8, 2C, PUR	ø2.8, 3C, PUR	
<b>Operating Frequency</b>	200 Hz	1000 Hz	
<b>Magnet Requirement *2</b>	70 Gauss	40 Gauss	
<b>Temperature Range</b>	-10 ~ 70 °C		
<b>Shock *3</b>	30 G	50 G	
<b>Vibration *4</b>	9 G		
<b>Enclosure Classification</b>	IEC 60529 IP67		
<b>Protection Circuit *5</b>	1	3, 4	

**NOTE:**

\*1 : WARNING : Never exceed rating ( Watt = Voltage x Amperage ).  
Permanent damage to sensor will occur.

\*2 : Measuring standard target : ø15.5 × ø8 × 5t ( Anisotropy rubber magnet )

\*3 : Sin wave / X , Y , Z 3 directions / 3 times each direction / 11 ms each time.

\*4 : Double amplitude 1.5 mm / 10 Hz ~ 55 Hz ~ 10 Hz ( Sweep 1 min ) / X , Y , Z 3 directions / 1 hour each time.

\*5 : 1 = None / 2 = Short-circuit / 3 = Power Source Reverse polarity / 4 = Surge Suppression

### Groove Dimensions

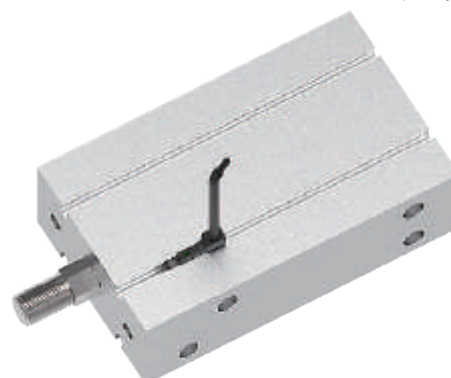
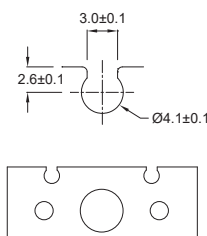

Unit : mm

# KT-20 SERIES



## Dimensions

KT-20R, KT-20DE, KT-20N, KT-20NE, KT-20P, KT-20PE /  
KT-20R-QD, KT-20DE-QD, KT-20N-QD, KT-20NE-QD,  
KT-20P-QD, KT-20PE-QD

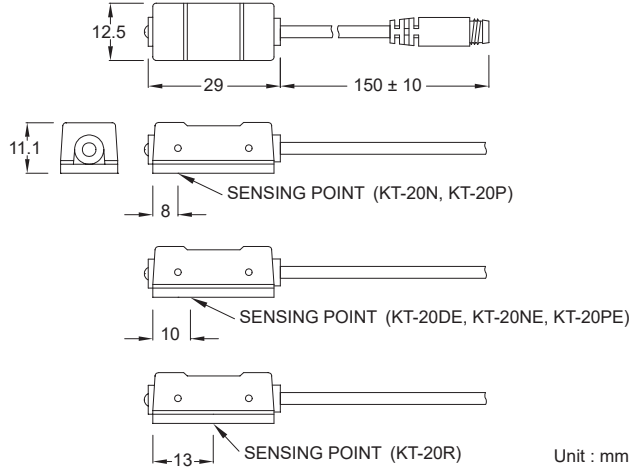

Unit : mm

## QD Pinout

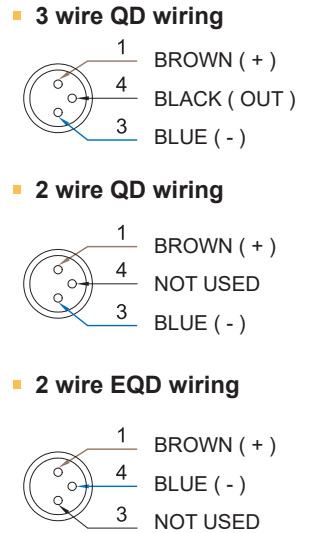

## Specifications

MODEL	KT-20R	KT-20DE	KT-20N	KT-20NE	KT-20P	KT-20PE
<b>Connect Diagram</b>						
<b>Characteristics</b>						
<b>Wiring Method</b>	2-Wire type		3-Wire type			
<b>Switching Logic</b>	SPST, Normally Open		Solid State Output, Normally Open			
<b>Sensor Type</b>	Reed Switch	-	NPN Current Sinking		PNP Current Sourcing	
<b>Operating Voltage</b>	5 ~ 240 V DC / AC		5 ~ 30 V DC			
<b>Switching Current</b>	100 mA max.	50 mA max.	200 mA max.			
<b>Contact Rating *1</b>	10 W max.	1.5 W max.	6 W max.			
<b>Current Consumption</b>	-		15 mA @ 24 V DC max.	6 mA @ 24 V DC max.	15 mA @ 24 V DC max.	6 mA @ 24 V DC max.
<b>Voltage Drop</b>	3.5 V max.	3.7 V max.	1.5 V max.	0.5 V max.	1.5 V max.	0.5 V max.
<b>Leakage Current</b>	-	0.1 mA (40 uA) max.	0.01 mA max.			
<b>Indicator</b>	Green LED		Red LED		Green LED	
<b>Cable</b>	ø4, 2C, PVC		ø4, 3C, PVC			
<b>Operating Frequency</b>	200 Hz		1000 Hz max.			
<b>Magnet Requirement *2</b>	80 Gauss	50 ~ 1000 Gauss	70 Gauss	50 ~ 1000 Gauss	70 Gauss	50 ~ 1000 Gauss
<b>Temperature Range</b>	-10 ~ 70 °C					
<b>Shock *3</b>	30 G		50 G			
<b>Vibration *4</b>	9 G					
<b>Enclosure Classification</b>	IEC 60529 IP67					
<b>Protection Circuit *5</b>	1	3, 4	2, 3, 4	3, 4	2, 3, 4	3, 4

**NOTE:**

\*1 : WARNING : Never exceed rating ( Watt = Voltage x Amperage ).  
Permanent damage to sensor will occur.

\*2 : Measuring standard target : ø15.5 × ø8 × 5t ( Anisotropy rubber magnet )

\*3 : Sin wave / X , Y , Z 3 directions / 3 times each direction / 11 ms each time.

\*4 : Double amplitude 1.5 mm / 10 Hz ~ 55 Hz ~ 10 Hz ( Sweep 1 min ) / X , Y , Z 3 directions / 1 hour each time.

\*5 : 1 = None / 2 = Short-circuit / 3 = Power Source Reverse polarity / 4 = Surge Suppression

## Clamps / Bracket

KT-20 & KT-21 series can be applied to many kind of cylinders

PH Series

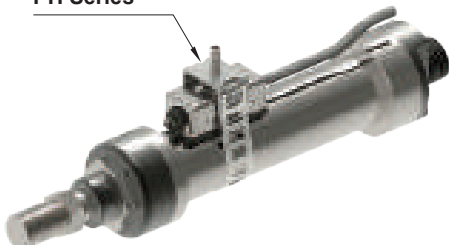

PI Series

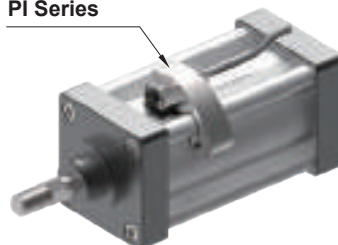

# KT-21 SERIES



### Dimensions

KT-21R, KT-21DE, KT-21N, KT-21NE, KT-21P, KT-21PE /  
KT-21R-QD, KT-21DE-QD, KT-21N-QD, KT-21NE-QD,  
KT-21P-QD, KT-21PE-QD

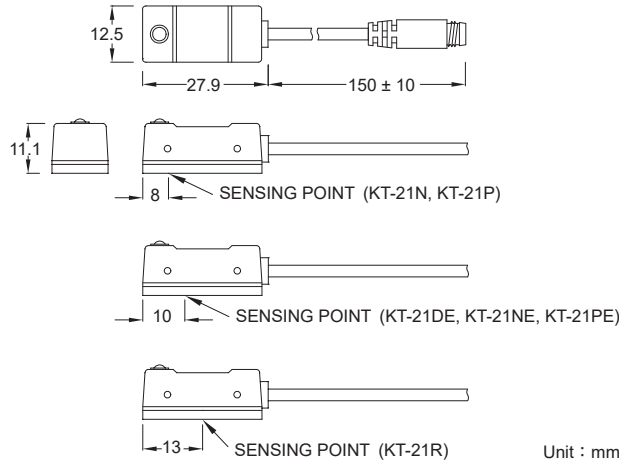

Unit : mm

### QD Pinout

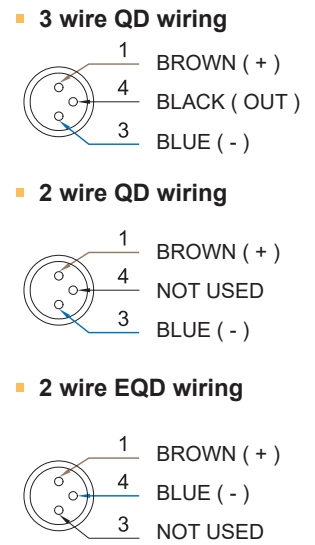

### Specifications

MODEL	KT-21R	KT-21DE	KT-21N	KT-21NE	KT-21P	KT-21PE
Connect Diagram						
Characteristics						
Wiring Method	2-Wire type		3-Wire type			
Switching Logic	SPST, Normally Open		Solid State Output, Normally Open			
Sensor Type	Reed Switch	-	NPN Current Sinking		PNP Current Sourcing	
Operating Voltage	5 ~ 240 V DC / AC		5 ~ 30 V DC			
Switching Current	100 mA max.	50 mA max.	200 mA max.			
Contact Rating *1	10 W max.	1.5 W max.	6 W max.			
Current Consumption	-		15 mA @ 24 V DC max.	6 mA @ 24 V DC max.	15 mA @ 24 V DC max.	6 mA @ 24 V DC max.
Voltage Drop	3.5 V max.	3.7 V max.	1.5 V max.	0.5 V max.	1.5 V max.	0.5 V max.
Leakage Current	-	0.1 mA (40 uA) max.	0.01 mA max.			
Indicator	Green LED		Red LED		Green LED	
Cable	ø4, 2C, PVC		ø4, 3C, PVC			
Operating Frequency	200 Hz		1000 Hz max.			
Magnet Requirement *2	80 Gauss	50 ~ 1000 Gauss	70 Gauss	50 ~ 1000 Gauss	70 Gauss	50 ~ 1000 Gauss
Temperature Range	-10 ~ 70 °C					
Shock *3	30 G		50 G			
Vibration *4	9 G					
Enclosure Classification	IEC 60529 IP67					
Protection Circuit *5	1	3, 4	2, 3, 4	3, 4	2, 3, 4	3, 4

**NOTE:**

\*1 : WARNING : Never exceed rating ( Watt = Voltage x Amperage ). Permanent damage to sensor will occur.

\*2 : Measuring standard target : ø15.5 × ø8 × 5t ( Anisotropy rubber magnet )

\*3 : Sin wave / X , Y , Z 3 directions / 3 times each direction / 11 ms each time.

\*4 : Double amplitude 1.5 mm / 10 Hz ~ 55 Hz ~ 10 Hz ( Sweep 1 min ) / X , Y , Z 3 directions / 1 hour each time.

\*5 : 1 = None / 2 = Short-circuit / 3 = Power Source Reverse polarity / 4 = Surge Suppression

### Clamps / Bracket

KT-20 & KT-21 series can be applied to many kind of cylinders

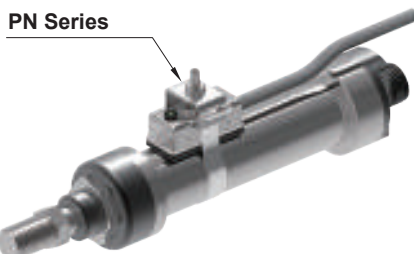

# KT-31 SERIES



High Temp. Resistant  
Max 140°C

## Dimensions

M8 Connector  
option is not available

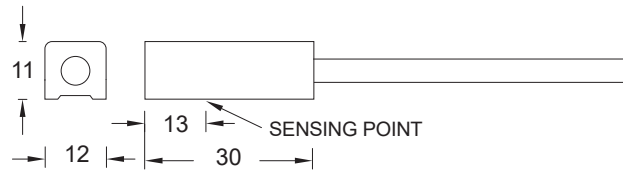

Unit : mm

## Specifications

MODEL	KT-31R
Connect Diagram	
Characteristics	
Wiring Method	2-Wire Type
Switching Logic	SPST, Normally Open
Sensor Type	Reed Switch
Operating Voltage	5 ~ 240 V DC / AC
Switching Current	500 mA max.
Contact Rating *1	10 W max.
Current Consumption	-
Voltage Drop	0.5 V max.
Leakage Current	-
Indicator	-
Cable	Ø 3, 2C, Teflon
Operating Frequency	200 Hz
Magnet Requirement *2	40 Gauss
Temperature Range	-10 ~ 140 °C
Shock *3	30 G
Vibration *4	9 G
Enclosure Classification	IEC 60529 IP67
Protection Circuit *5	1

**NOTE:**

\*1 : WARNING : Never exceed rating ( Watt = Voltage x Amperage ).  
Permanent damage to sensor will occur.

\*2 : Measuring standard target : ø15.5 × ø8 × 5t ( Anisotropy rubber magnet )

\*3 : Sin wave / X , Y , Z 3 directions / 3 times each direction / 11 ms each time.

\*4 : Double amplitude 1.5 mm / 10 Hz ~ 55 Hz ~ 10 Hz ( Sweep 1 min ) / X , Y , Z 3 directions / 1 hour each time.

\*5 : 1 = None / 2 = Short-circuit / 3 = Power Source Reverse polarity / 4 = Surge Suppression

## Bracket

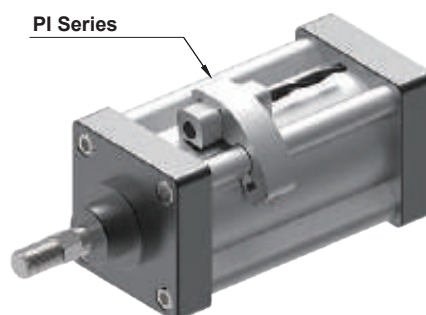

## Dimensions

KT-32R, KT-32N, KT-32P, KT-32RP /  
KT-32R-QD, KT-32N-QD, KT-32P-QD, KT-32RP-QD

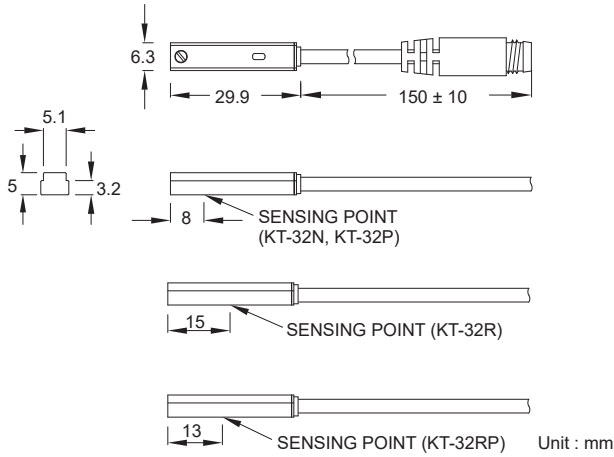

## QD Pinout

### 3 wire QD wiring

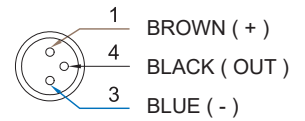

### 2 wire QD wiring

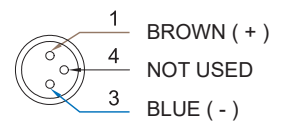

### 2 wire EQD wiring

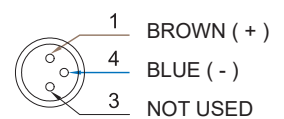

## Specifications

MODEL	KT-32R	KT-32N	KT-32P	KT-32RP
<b>Connect Diagram</b>				
<b>Characteristics</b>				
<b>Wiring Method</b>	2-Wire Type	3-Wire Type		
<b>Switching Logic</b>	SPST, Normally Open	Solid State Output, Normally Open		SPST, Normally Open
<b>Sensor Type</b>	Reed Switch	NPN Current Sinking	PNP Current Sourcing	Reed Switch
<b>Operating Voltage</b>	5 ~ 240 V DC / AC	10 ~ 30 V DC		10 ~ 30 V DC / AC
<b>Switching Current</b>		100 mA max.		500 mA max.
<b>Contact Rating *1</b>	10 W max.	3 W max.		10 W max.
<b>Current Consumption</b>	-	17 mA @ 24 V DC max.	8 mA @ 24 V DC max.	10 mA @ 24 V DC max.
<b>Voltage Drop</b>	3.5 V max.	1.5 V max.		0.1 V @ 100 mA max.
<b>Leakage Current</b>	-	0.01 mA max.		-
<b>Indicator</b>	Red LED		Yellow LED	
<b>Cable</b>	ø3.3, 2C, PVC		ø3.2, 3C, PVC	
<b>Operating Frequency</b>	200 Hz	1000 Hz		200 Hz
<b>Magnet Requirement *2</b>	70 Gauss	60 Gauss		
<b>Temperature Range</b>	-10 ~ 70 °C			
<b>Shock *3</b>	30 G	50 G		30 G
<b>Vibration *4</b>	9 G			
<b>Enclosure Classification</b>	IEC 60529 IP67			
<b>Protection Circuit *5</b>	1	2, 3, 4		1

**NOTE:**

\*1 : WARNING : Never exceed rating ( Watt = Voltage x Amperage ).  
Permanent damage to sensor will occur.

\*2 : Measuring standard target : ø15.5 × ø8 × 5t ( Anisotropy rubber magnet )

\*3 : Sin wave / X , Y , Z 3 directions / 3 times each direction / 11 ms each time.

\*4 : Double amplitude 1.5 mm / 10 Hz ~ 55 Hz ~ 10 Hz ( Sweep 1 min ) / X , Y , Z 3 directions / 1 hour each time.

\*5 : 1 = None / 2 = Short-circuit / 3 = Power Source Reverse polarity / 4 = Surge Suppression

## Groove Dimensions

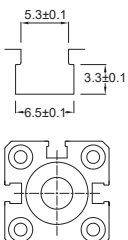

## Bracket

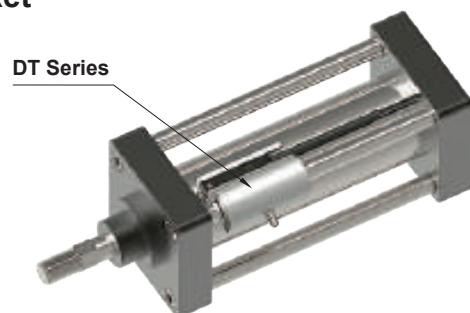

Unit : mm

# KT-32-EX SERIES



**Explosion Proof**

## Dimensions

KT-32R-EX, KT-32N-EX, KT-32P-EX, KT-32RP-EX

**M8 Connector option is not available**

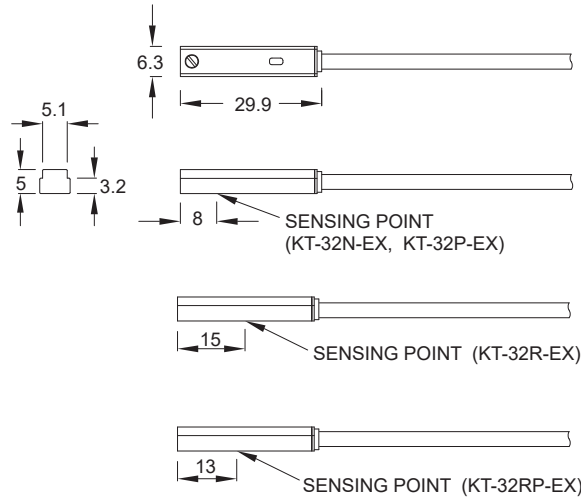

## Specifications

Unit : mm

MODEL	KT-32R-EX	KT-32N-EX	KT-32P-EX	KT-32RP-EX
<b>Connect Diagram</b>				
<b>Characteristics</b>				
<b>Wiring Method</b>	2-Wire Type	3-Wire Type		
<b>Switching Logic</b>	SPST, Normally Open	Solid State Output, Normally Open		SPST, Normally Open
<b>Sensor Type</b>	Reed Switch	NPN Current Sinking	PNP Current Sourcing	Reed Switch
<b>Operating Voltage</b>	5 ~ 30 V DC / AC	10 ~ 30 V DC		10 ~ 30 V DC / AC
<b>Switching Current</b>		100 mA max.		500 mA max.
<b>Contact Rating *1</b>	10 W max.	3 W max.		10 W max.
<b>Current Consumption</b>	-	17 mA @ 24 V DC max.	8 mA @ 24 V DC max.	10 mA @ 24 V DC max.
<b>Voltage Drop</b>	3.5 V max.	1.5 V max.		0.1 V @ 100 mA max.
<b>Leakage Current</b>	-	0.01 mA max.		-
<b>Indicator</b>	Red LED		Yellow LED	
<b>Cable</b>	ø3.3, 2C, PVC	ø3.2, 3C, PVC		
<b>Operating Frequency</b>	200 Hz	1000 Hz		200 Hz
<b>Magnet Requirement *2</b>	70 Gauss	60 Gauss		
<b>Temperature Range</b>	-10 ~ 70 °C			
<b>Shock *3</b>	30 G	50 G		30 G
<b>Vibration *4</b>	9 G			
<b>Enclosure Classification</b>	IEC 60529 IP67			
<b>Protection Circuit *5</b>	1	2, 3, 4		1
<b>CE ATEX APPROVAL Baseefa14ATEX0118</b>	II 3GD Ex ic IIB T4 Gc ( -10 °C ≤ Ta ≤ +70 °C ) Ex ic IIIC T135°C Dc ( -10 °C ≤ Ta ≤ +70 °C )			

**NOTE:**

\*1 : WARNING : Never exceed rating ( Watt = Voltage x Amperage ). Permanent damage to sensor will occur.

\*2 : Measuring standard target : ø15.5 × ø8 × 5t ( Anisotropy rubber magnet )

\*3 : Sin wave / X , Y , Z 3 directions / 3 times each direction / 11 ms each time.

\*4 : Double amplitude 1.5 mm / 10 Hz ~ 55 Hz ~ 10 Hz ( Sweep 1 min ) / X , Y , Z 3 directions / 1 hour each time.

\*5 : 1 = None / 2 = Short-circuit / 3 = Power Source Reverse polarity / 4 = Surge Suppression

## Groove Dimensions

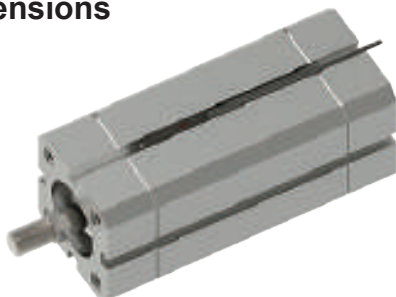
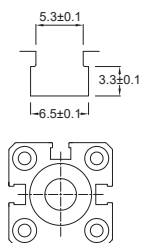

## Bracket

DT Series

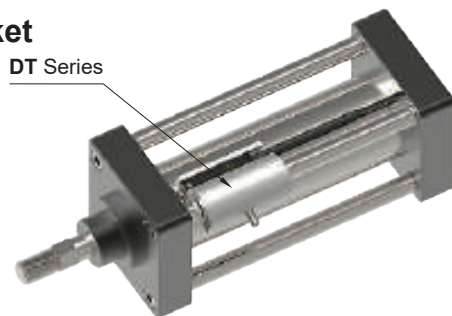

Unit : mm

# KT-33 SERIES



### Dimensions



KT-33R, KT-33D, KT-33N, KT-33P /  
KT-33R-QD, KT-33D-QD, KT-33N-QD, KT-33P-QD

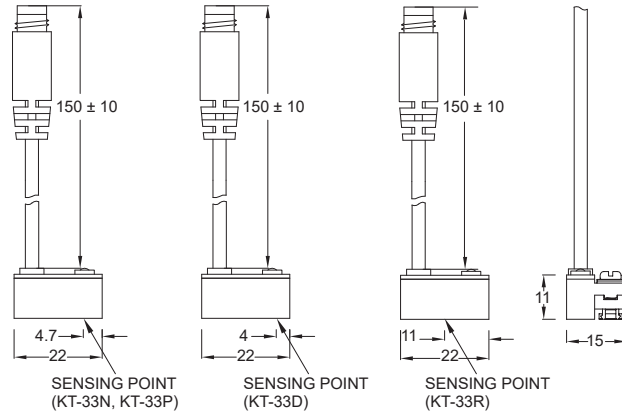

Unit : mm

### QD Pinout

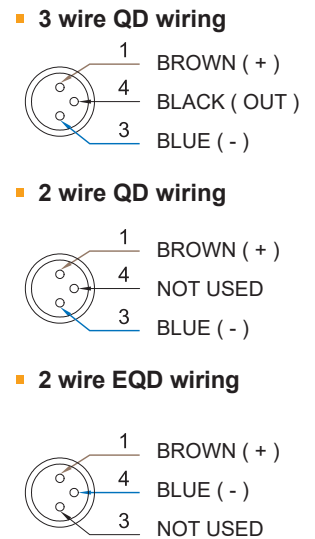

### Specifications

MODEL	KT-33R	KT-33D	KT-33N	KT-33P
<b>Connect Diagram</b>				
<b>Characteristics</b>				
<b>Wiring Method</b>	2-Wire Type		3-Wire Type	
<b>Switching Logic</b>	SPST, Normally Open		Solid State Output, Normally Open	
<b>Sensor Type</b>	Reed Switch	-	NPN Current Sinking	PNP Current Sourcing
<b>Operating Voltage</b>	5 ~ 240 V DC / AC		10 ~ 28 V DC	
<b>Switching Current</b>	100 mA max.		4 ~ 40 mA max.	
<b>Contact Rating *1</b>	10 W max.		1.5 W max.	
<b>Current Consumption</b>	-		22 mA @ 24 V DC max.	20 mA @ 24 V DC max.
<b>Voltage Drop</b>	3.5 V max.		0.5 V max.	
<b>Leakage Current</b>	-		1 mA max.	0.01 mA max.
<b>Indicator</b>	Red LED	Green LED	Red LED	Green LED
<b>Cable</b>	ø3.3, 2C, PVC		ø3.3, 3C, PVC	
<b>Operating Frequency</b>	200 Hz		1000 Hz	
<b>Magnet Requirement *2</b>	80 Gauss		70 Gauss	
<b>Temperature Range</b>	-10 ~ 70 °C			
<b>Shock *3</b>	30 G		50 G	
<b>Vibration *4</b>	9 G			
<b>Enclosure Classification</b>	IEC 60529 IP67			
<b>Protection Circuit *5</b>	1	4	3, 4	

**NOTE:**

\*1 : WARNING : Never exceed rating ( Watt = Voltage x Amperage ).  
Permanent damage to sensor will occur.

\*2 : Measuring standard target : ø15.5 × ø8 × 5t ( Anisotropy rubber magnet )

\*3 : Sin wave / X, Y, Z 3 directions / 3 times each direction / 11 ms each time.

\*4 : Double amplitude 1.5 mm / 10 Hz ~ 55 Hz ~ 10 Hz ( Sweep 1 min ) / X, Y, Z 3 directions / 1 hour each time.

\*5 : 1 = None / 2 = Short-circuit / 3 = Power Source Reverse polarity / 4 = Surge Suppression

### Groove Dimensions

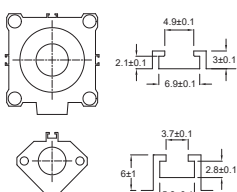

Unit : mm

# KT-36 SERIES



Compact Size

## Dimensions

KT-36D, KT-36DE, KT-36N, KT-36NE, KT-36P, KT-36PE, /  
KT-36D-QD, KT-36DE-QD, KT-36N-QD, KT-36NE-QD,  
KT-36P-QD, KT-36PE-QD

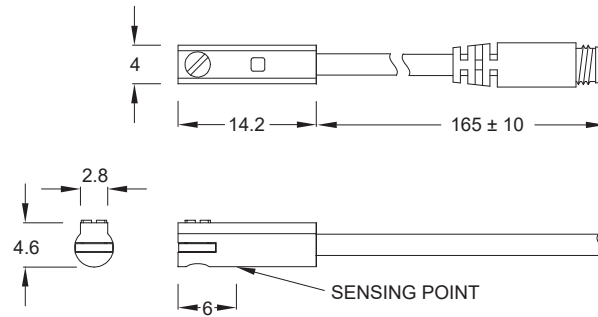

Unit : mm

## QD Pinout

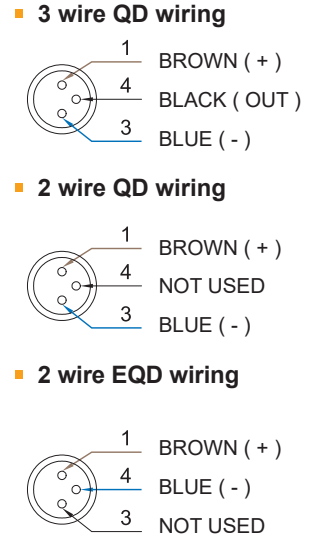

## Specifications

MODEL	KT-36D	KT-36DE	KT-36N	KT-36NE	KT-36P	KT-36PE
Connect Diagram						
Characteristics						
Wiring Method	2-Wire type		3-Wire type			
Switching Logic	Solid State Output, Normally Open					
Sensor Type	-		NPN Current Sinking		PNP Current Sourcing	
Operating Voltage	10 ~ 28 V DC	5 ~ 30 V DC	4.5 ~ 28 V DC	5 ~ 30 V DC	4.5 ~ 28 V DC	5 ~ 30 V DC
Switching Current	4 ~ 20 mA max.		50 mA max.			
Contact Rating *1	0.6 W max.		1.5 W max.			
Current Consumption	-		10 mA @ 24 V DC max.			
Voltage Drop	3.5 V max.		0.5 V @ 50 mA max.			
Leakage Current	0.8 mA max.	0.1 mA (40 uA) max.	0.01 mA max.			
Indicator	Red LED					
Cable	ø2.6, 2C, PVC		ø2.6, 3C, PVC			
Operating Frequency	1000 Hz max.					
Magnet Requirement *2	40 Gauss	40 ~ 1000 Gauss	40 Gauss	40 ~ 1000 Gauss	40 Gauss	40 ~ 1000 Gauss
Temperature Range	-10 ~ 70 °C					
Shock *3	50 G					
Vibration *4	9 G					
Enclosure Classification	IEC 60529 IP67					
Protection Circuit *5	4		3, 4			

### NOTE:

\*1 : WARNING : Never exceed rating ( Watt = Voltage x Amperage ).  
Permanent damage to sensor will occur.

\*2 : Measuring standard target : ø15.5 × ø8 × 5t ( Anisotropy rubber magnet )

\*3 : Sin wave / X , Y , Z 3 directions / 3 times each direction / 11 ms each time.

\*4 : Double amplitude 1.5 mm / 10 Hz ~ 55 Hz ~ 10 Hz ( Sweep 1 min ) / X , Y , Z 3 directions / 1 hour each time.

\*5 : 1 = None / 2 = Short-circuit / 3 = Power Source Reverse polarity / 4 = Surge Suppression

## Groove Dimensions

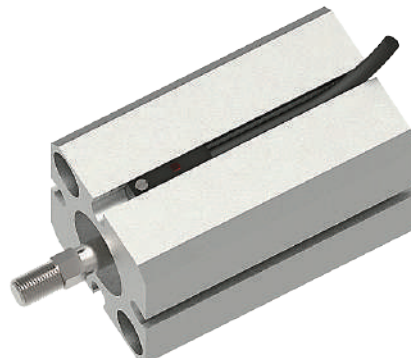
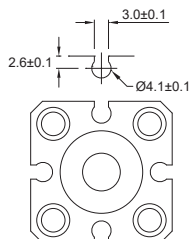

Unit : mm

# KT-37 SERIES



## Compact Size



## Dimensions

KT-37D, KT-37DE, KT-37N, KT-37NE, KT-37P, KT-37PE, /  
KT-37D-QD, KT-37DE-QD, KT-37N-QD, KT-37NE-QD,  
KT-37P-QD, KT-37PE-QD

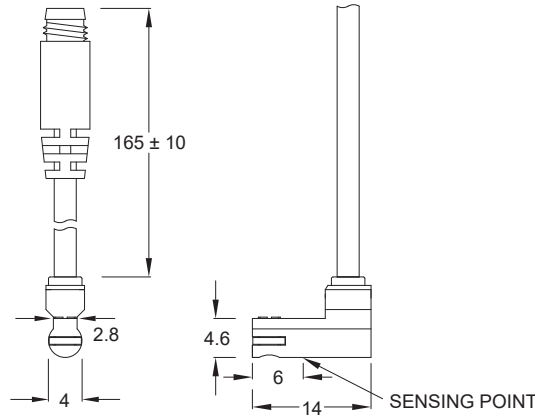

Unit : mm

## QD Pinout

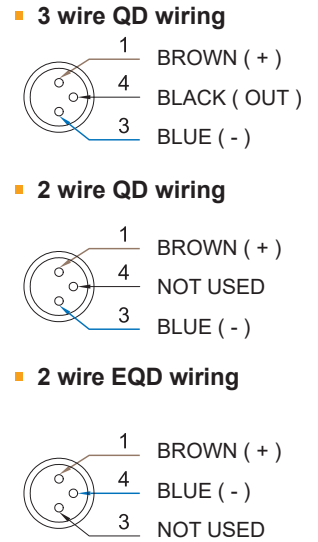

## Specifications

MODEL	KT-37D	KT-37DE	KT-37N	KT-37NE	KT-37P	KT-37PE
Connect Diagram						
Characteristics	-		NPN Current Sinking		PNP Current Sourcing	
Wiring Method	2-Wire type		3-Wire type			
Switching Logic	Solid State Output, Normally Open					
Sensor Type	-		NPN Current Sinking		PNP Current Sourcing	
Operating Voltage	10 ~ 28 V DC	5 ~ 30 V DC	4.5 ~ 28 V DC	5 ~ 30 V DC	4.5 ~ 28 V DC	5 ~ 30 V DC
Switching Current	4 ~ 20 mA max.	50 mA max.				
Contact Rating *1	0.6 W max.	1.5 W max.				
Current Consumption	-		10 mA @ 24 V DC max.			
Voltage Drop	3.5 V max.		0.5 V @ 50 mA max.			
Leakage Current	0.8 mA max.	0.1 mA (40 uA) max.	0.01 mA max.			
Indicator	Red LED					
Cable	ø2.6, 2C, PVC		ø2.6, 3C, PVC			
Operating Frequency	1000 Hz max.					
Magnet Requirement *2	40 Gauss	40 ~ 1000 Gauss	40 Gauss	40 ~ 1000 Gauss	40 Gauss	40 ~ 1000 Gauss
Temperature Range	-10 ~ 70 °C					
Shock *3	50 G					
Vibration *4	9 G					
Enclosure Classification	IEC 60529 IP67					
Protection Circuit *5	4		3, 4			

### NOTE:

\*1 : WARNING : Never exceed rating ( Watt = Voltage x Amperage ).  
Permanent damage to sensor will occur.

\*2 : Measuring standard target : ø15.5 × ø8 × 5t ( Anisotropy rubber magnet )

\*3 : Sin wave / X , Y , Z 3 directions / 3 times each direction / 11 ms each time.

\*4 : Double amplitude 1.5 mm / 10 Hz ~ 55 Hz ~ 10 Hz ( Sweep 1 min ) / X , Y , Z 3 directions / 1 hour each time.

\*5 : 1 = None / 2 = Short-circuit / 3 = Power Source Reverse polarity / 4 = Surge Suppression

## Groove Dimensions

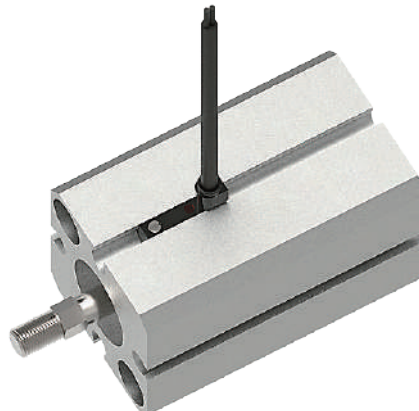
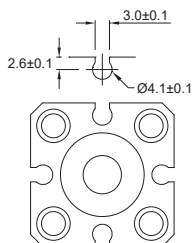

Unit : mm

# KT-38 SERIES



Compact Size



## Dimensions

KT-38D, KT-38N, KT-38P /  
KT-38D-QD, KT-38N-QD, KT-38P-QD

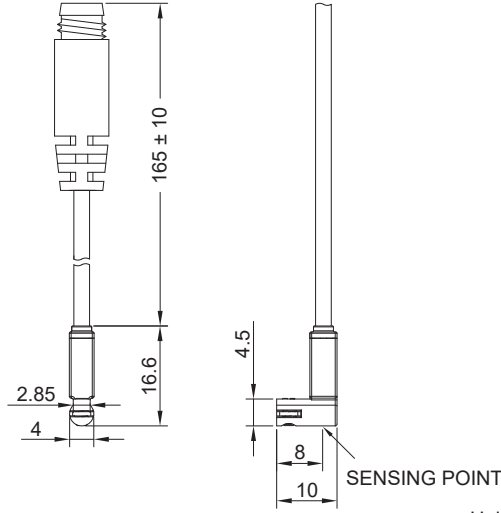

Unit : mm

## QD Pinout

### 3 wire QD wiring

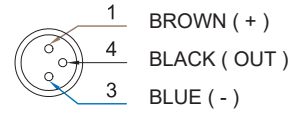

### 2 wire QD wiring

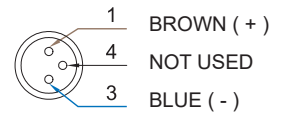

### 2 wire EQD wiring

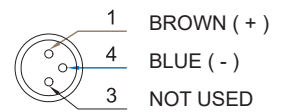

## Specifications

MODEL	KT-38D	KT-38N	KT-38P
Connect Diagram			
Characteristics			
Wiring Method	2-Wire Type	3-Wire Type	
Switching Logic	Solid State Output, Normally Open		
Sensor Type	-	NPN Current Sinking	PNP Current Sourcing
Operating Voltage	10 ~ 28 V DC	5 ~ 28 V DC	
Switching Current	4 ~ 20 mA max.	50 mA max.	
Contact Rating *1	0.6 W max.	1.5 W max.	
Current Consumption	-	10 mA @ 24 V DC max.	
Voltage Drop	3.5 V max.	0.5 V @ 50 mA max.	
Leakage Current	0.8 mA max.	0.01 mA max.	
Indicator	Red LED		
Cable	ø2.6, 2C, PVC	ø2.6, 3C, PVC	
Operating Frequency	1000 Hz		
Magnet Requirement *2	40 Gauss		
Temperature Range	-10 ~ 70 °C		
Shock *3	50 G		
Vibration *4	9 G		
Enclosure Classification	IEC 60529 IP67		
Protection Circuit *5	4	3, 4	

### NOTE:

\*1 : WARNING : Never exceed rating ( Watt = Voltage x Amperage ).  
Permanent damage to sensor will occur.

\*2 : Measuring standard target : ø15.5 × ø8 × 5t ( Anisotropy rubber magnet )

\*3 : Sin wave / X , Y , Z 3 directions / 3 times each direction / 11 ms each time.

\*4 : Double amplitude 1.5 mm / 10 Hz ~ 55 Hz ~ 10 Hz ( Sweep 1 min ) / X , Y , Z 3 directions / 1 hour each time.

\*5 : 1 = None / 2 = Short-circuit / 3 = Power Source Reverse polarity / 4 = Surge Suppression

## Groove Dimensions

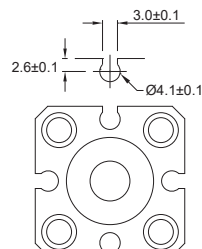

Unit : mm

# KT-40 SERIES



## Dimensions

KT-40R, KT-40N, KT-40P, KT-40RP /  
KT-40R-QD, KT-40N-QD, KT-40P-QD, KT-40RP-QD

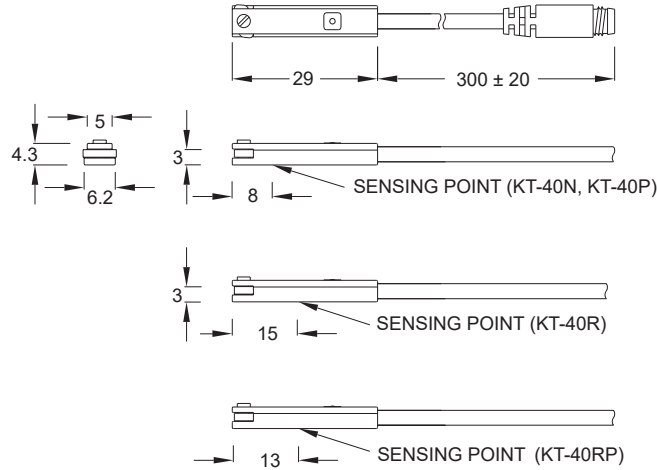

## QD Pinout

### 3 wire QD wiring

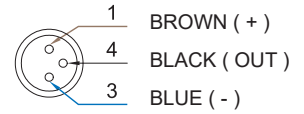

### 2 wire QD wiring

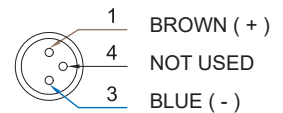

### 2 wire EQD wiring

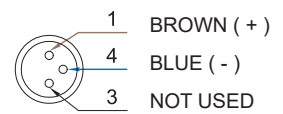

Unit : mm

## Specifications

MODEL	KT-40R	KT-40N	KT-40P	KT-40RP
Connect Diagram				
Characteristics				
Wiring Method	2-Wire Type	3-Wire Type		
Switching Logic	SPST, Normally Open	Solid State Output, Normally Open		SPST, Normally Open
Sensor Type	Reed Switch	NPN Current Sinking	PNP Current Sourcing	Reed Switch
Operating Voltage	5 ~ 120 V DC / AC	10 ~ 30 V DC		10 ~ 30 V DC / AC
Switching Current		100 mA max.		500 mA max.
Contact Rating *1	10 W max.	3 W max.		10 W max.
Current Consumption	-	8 mA @ 24 V DC max.		10 mA @ 24 V DC max.
Voltage Drop	3.5 V max.	1.5 V max.		0.1 V @ 100 mA max.
Leakage Current	-	0.01 mA max.		-
Indicator	Red LED		Yellow LED	
Cable	ø3, 2C, PUR	ø3, 3C, PUR		
Operating Frequency	200 Hz	1000 Hz		200 Hz
Magnet Requirement *2	50 Gauss	45 Gauss		
Temperature Range	-10 ~ 70 °C			
Shock *3	30 G	50 G		30 G
Vibration *4	9 G			
Enclosure Classification	IEC 60529 IP67			
Protection Circuit *5	1	2, 3, 4		1

### NOTE:

\*1 : WARNING : Never exceed rating ( Watt = Voltage x Amperage ).  
Permanent damage to sensor will occur.

\*2 : Measuring standard target : ø15.5 × ø8 × 5t ( Anisotropy rubber magnet )

\*3 : Sin wave / X , Y , Z 3 directions / 3 times each direction / 11 ms each time.

\*4 : Double amplitude 1.5 mm / 10 Hz ~ 55 Hz ~ 10 Hz ( Sweep 1 min ) / X , Y , Z 3 directions / 1 hour each time.

\*5 : 1 = None / 2 = Short-circuit / 3 = Power Source Reverse polarity / 4 = Surge Suppression

## Groove Dimensions

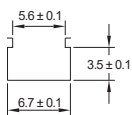

## Clamp / Bracket

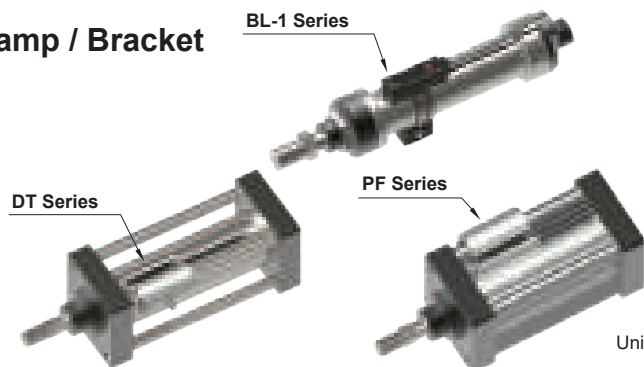

Unit : mm

# KT-47 SERIES



## Dimensions

KT-47R, KT-47N, KT-47P /  
KT-47R-QD, KT-47N-QD, KT-47P-QD

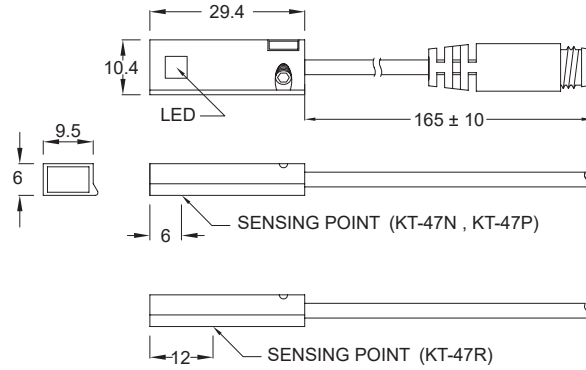

Unit : mm

## QD Pinout

### 3 wire QD wiring

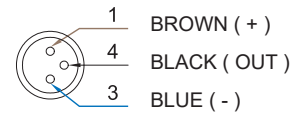

### 2 wire QD wiring

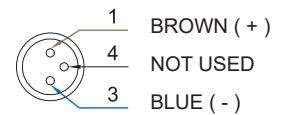

### 2 wire EQD wiring

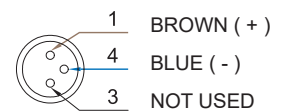

## Specifications

MODEL	KT-47R	KT-47N	KT-47P
Connect Diagram			
Characteristics			
Wiring Method	2-Wire Type	3-Wire Type	
Switching Logic	SPST, Normally Open	Solid State Output, Normally Open	
Sensor Type	Reed Switch	NPN Current Sinking	PNP Current Sourcing
Operating Voltage	5 ~ 240 V DC / AC	5 ~ 30 V DC	
Switching Current	500 mA max.	200 mA max.	
Contact Rating *1	10 W max.	6 W max.	
Current Consumption	-	22 mA @ 24 V DC max.	20 mA @ 24 V DC max.
Voltage Drop	3.0 V max.	2.0 V max.	2.5 V max.
Leakage Current	-	0.01 mA max.	
Indicator	Yellow LED		
Cable	ø2.8, 2C, PVC	ø2.8, 3C, PUR	
Operating Frequency	200 Hz	1000 Hz	
Magnet Requirement *2	50 Gauss		
Temperature Range	-10 ~ 70 °C		
Shock *3	30 G	50 G	
Vibration *4	9 G		
Enclosure Classification	IEC 60529 IP67		
Protection Circuit *5	1	2, 3, 4	

### NOTE:

\*1 : WARNING : Never exceed rating ( Watt = Voltage x Amperage ).

Permanent damage to sensor will occur.

\*2 : Measuring standard target : ø15.5 × ø8 × 5t ( Anisotropy rubber magnet )

\*3 : Sin wave / X , Y , Z 3 directions / 3 times each direction / 11 ms each time.

\*4 : Double amplitude 1.5 mm / 10 Hz ~ 55 Hz ~ 10 Hz ( Sweep 1 min ) / X , Y , Z 3 directions / 1 hour each time.

\*5 : 1 = None / 2 = Short-circuit / 3 = Power Source Reverse polarity / 4 = Surge Suppression

## Groove Dimensions

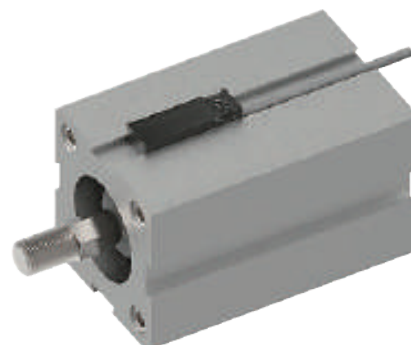
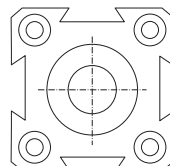
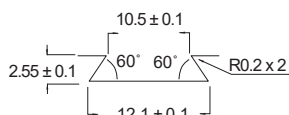

Unit : mm

# KT-48 SERIES



## Dimensions

KT-48R, KT-48DE, KT-48N, KT-48NE, KT-48P, KT-48PE /  
KT-48R-QD, KT-48DE-QD, KT-48N-QD, KT-48NE-QD,  
KT-48P-QD, KT-48PE-QD

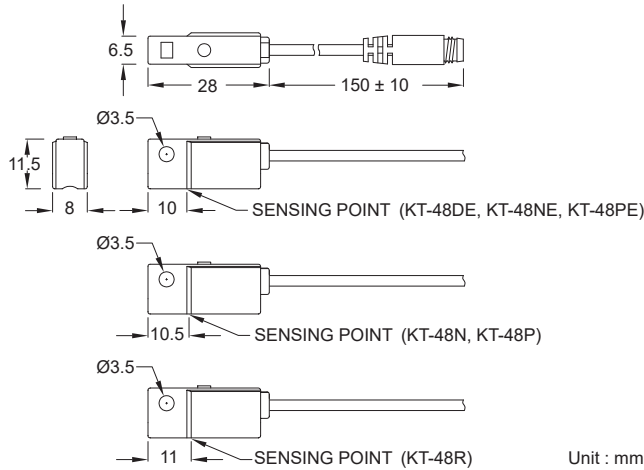

## QD Pinout

- 3 wire QD wiring
  - 1 BROWN (+)
  - 4 BLACK (OUT)
  - 3 BLUE (-)
- 2 wire QD wiring
  - 1 BROWN (+)
  - 4 NOT USED
  - 3 BLUE (-)
- 2 wire EQD wiring
  - 1 BROWN (+)
  - 4 BLUE (-)
  - 3 NOT USED

## Specifications

MODEL	KT-48R	KT-48DE	KT-48N	KT-48NE	KT-48P	KT-48PE
Connect Diagram						
Characteristics	2-Wire type		3-Wire type			
Wiring Method	2-Wire type		3-Wire type			
Switching Logic	SPST, Normally Open	Solid State Output, Normally Open				
Sensor Type	Reed Switch	-	NPN Current Sinking		PNP Current Sourcing	
Operating Voltage	5 ~ 240 V DC / AC	5 ~ 30 V DC	5 ~ 28 V DC	5 ~ 30 V DC	5 ~ 28 V DC	5 ~ 30 V DC
Switching Current	100 mA max.	50 mA max.		200 mA max.	50 mA max.	200 mA max.
Contact Rating *1	10 W max.	1.5 W max.		6 W max.	1.5 W max.	6 W max.
Current Consumption	-	10 mA @ 24 V DC max.		6 mA @ 24 V DC max.	10 mA @ 24 V DC max.	6 mA @ 24 V DC max.
Voltage Drop	3.5 V max.	3.7 V max.	1.5 V @ 50 mA max.	0.5 V @ 200 mA max.	1.5 V @ 50 mA max.	0.5 V @ 200 mA max.
Leakage Current	-	0.1 mA (40 uA) max.	0.01 mA max.			
Indicator	Red LED			Green LED		
Cable	ø 3.3, 2C, PVC			ø 3.3, 3C, PVC		
Operating Frequency	200 Hz			1000 Hz max.		
Magnet Requirement *2	110 Gauss	40 ~ 1000 Gauss	75 Gauss	40 ~ 1000 Gauss	75 Gauss	40 ~ 1000 Gauss
Temperature Range	-10 ~ 70 °C					
Shock *3	30 G			50 G		
Vibration *4	9 G					
Enclosure Classification	IEC 60529 IP67					
Protection Circuit *5	1	3, 4				

### NOTE:

\*1 : WARNING : Never exceed rating ( Watt = Voltage x Amperage ).  
Permanent damage to sensor will occur.

\*2 : Measuring standard target : ø15.5 × ø8 × 5t ( Anisotropy rubber magnet )

\*3 : Sin wave / X , Y , Z 3 directions / 3 times each direction / 11 ms each time.

\*4 : Double amplitude 1.5 mm / 10 Hz ~ 55 Hz ~ 10 Hz ( Sweep 1 min ) / X , Y , Z 3 directions / 1 hour each time.

\*5 : 1 = None / 2 = Short-circuit / 3 = Power Source Reverse polarity / 4 = Surge Suppression

## Clamp

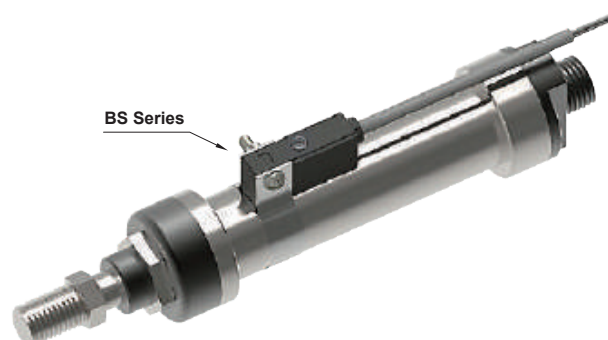
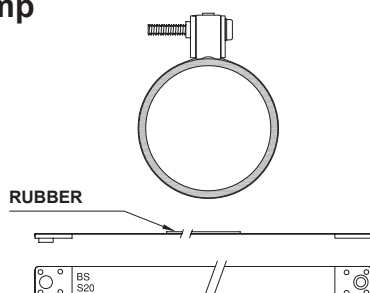

# KT-50 SERIES



Patented



## Dimensions

KT-50R, KT-50D, KT-50N, KT-50P, KT-50RP, /  
KT-50R-QD, KT-50D-QD, KT-50N-QD, KT-50P-QD,  
KT-50RP-QD

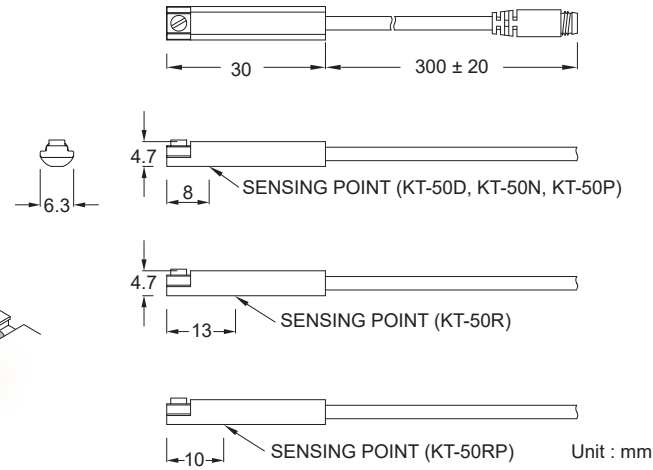

## QD Pinout

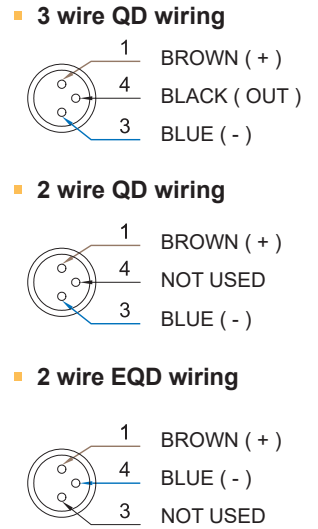

## Specifications

MODEL	KT-50R	KT-50D	KT-50N	KT-50P	KT-50RP
<b>Connect Diagram</b>					
<b>Characteristics</b>	2-Wire Type		3-Wire Type		
<b>Wiring Method</b>	2-Wire Type		3-Wire Type		
<b>Switching Logic</b>	SPST, Normally Open	Solid State Output, Normally Open			SPST, Normally Open
<b>Sensor Type</b>	Reed Switch	-	NPN Current Sinking	PNP Current Sourcing	Reed Switch
<b>Operating Voltage</b>	5 ~ 240 V DC / AC	10 ~ 28 V DC	10 ~ 30 V DC		10 ~ 30 V DC / AC
<b>Switching Current</b>	100 mA max.	50 mA max.	200 mA max.		500 mA max.
<b>Contact Rating *1</b>	10 W max.	1.5 W max.	6 W max.		10 W max.
<b>Current Consumption</b>	-		20 mA @ 24 V DC max.		5 mA @ 24 V DC max.
<b>Voltage Drop</b>	3.5 V max.		1.5 V max.		0.1 V @ 100 mA max.
<b>Leakage Current</b>	-	0.8 mA max.	0.05 mA max.		-
<b>Indicator</b>	Red LED			Yellow LED	
<b>Cable</b>	ø3, 2C, PUR			ø3, 3C, PUR	
<b>Operating Frequency</b>	200 Hz		1000 Hz		200 Hz
<b>Magnet Requirement *2</b>			70 Gauss		
<b>Temperature Range</b>			-10 ~ 70 °C		
<b>Shock *3</b>	30 G		50 G		30 G
<b>Vibration *4</b>			9 G		
<b>Enclosure Classification</b>	IEC 60529 IP67				
<b>Protection Circuit *5</b>	1	2, 4	2, 3, 4		1

**NOTE:**

\*1 : WARNING : Never exceed rating ( Watt = Voltage x Amperage ).  
Permanent damage to sensor will occur.

\*2 : Measuring standard target : ø15.5 × ø8 × 5t ( Anisotropy rubber magnet )

\*3 : Sin wave / X , Y , Z 3 directions / 3 times each direction / 11 ms each time.

\*4 : Double amplitude 1.5 mm / 10 Hz ~ 55 Hz ~ 10 Hz ( Sweep 1 min ) / X , Y , Z 3 directions / 1 hour each time.

\*5 : 1 = None / 2 = Short-circuit / 3 = Power Source Reverse polarity / 4 = Surge Suppression

## Groove Dimensions | Clamp / Bracket

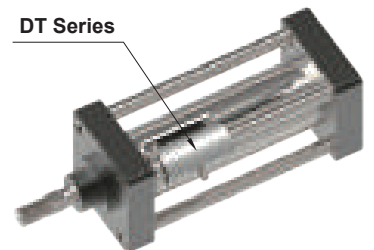
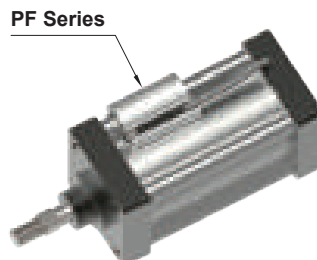
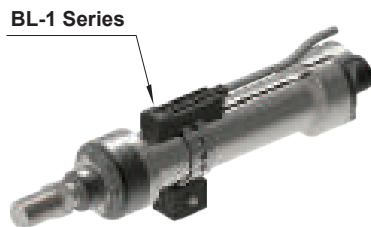
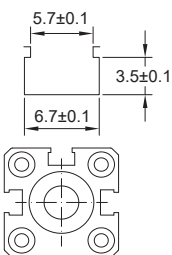

Unit : mm

# KT-53 SERIES



## Dimensions

KT-53R, KT-53D, KT-53N, KT-53P, KT-53RP /  
KT-53R-QD, KT-53D-QD, KT-53N-QD, KT-53P-QD,  
KT-53RP-QD

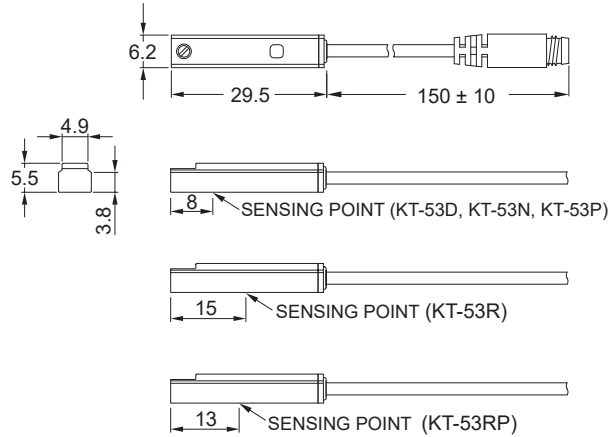

Unit : mm

## QD Pinout

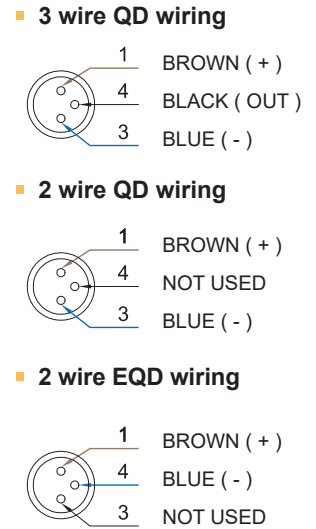

## Specifications

MODEL	KT-53R	KT-53D	KT-53N	KT-53P	KT-53RP
<b>Connect Diagram</b>					
<b>Characteristics</b>	2-Wire Type		3-Wire Type		
<b>Wiring Method</b>	2-Wire Type		3-Wire Type		
<b>Switching Logic</b>	SPST, Normally Open	Solid State Output, Normally Open			SPST, Normally Open
<b>Sensor Type</b>	Reed Switch	-	NPN Current Sinking	PNP Current Sourcing	Reed Switch
<b>Operating Voltage</b>	5 ~ 240 V DC / AC	10 ~ 28 V DC	10 ~ 30 V DC		10 ~ 30 V DC / AC
<b>Switching Current</b>	100 mA max.	50 mA max.	100 mA max.		500 mA max.
<b>Contact Rating *1</b>	10 W max.	1.5 W max.	3 W max.		10 W max.
<b>Current Consumption</b>	-	-	8 mA @ 24 V DC max.		10 mA @ 24 V DC max.
<b>Voltage Drop</b>	-	3.5 V max.	1.5 V max.		0.1 V @ 100 mA max.
<b>Leakage Current</b>	-	0.8 mA max.	0.01 mA max.		-
<b>Indicator</b>	Red LED			Yellow LED	
<b>Cable</b>	ø3, 2C, PUR			ø3, 3C, PUR	
<b>Operating Frequency</b>	200 Hz	-	1000 Hz		200 Hz
<b>Magnet Requirement *2</b>	70 Gauss	-	50 Gauss		70 Gauss
<b>Temperature Range</b>	-10 ~ 70 °C				
<b>Shock *3</b>	30 G	-	50 G		30 G
<b>Vibration *4</b>	9 G				
<b>Enclosure Classification</b>	IEC 60529 IP67				
<b>Protection Circuit *5</b>	1	2, 4	2, 3, 4		1

**NOTE:**

\*1 : WARNING : Never exceed rating ( Watt = Voltage x Amperage ).  
Permanent damage to sensor will occur.

\*2 : Measuring standard target : ø15.5 × ø8 × 5t ( Anisotropy rubber magnet )

\*3 : Sin wave / X , Y , Z 3 directions / 3 times each direction / 11 ms each time.

\*4 : Double amplitude 1.5 mm / 10 Hz ~ 55 Hz ~ 10 Hz ( Sweep 1 min ) / X , Y , Z 3 directions / 1 hour each time.

\*5 : 1 = None / 2 = Short-circuit / 3 = Power Source Reverse polarity / 4 = Surge Suppression

## Groove Dimensions

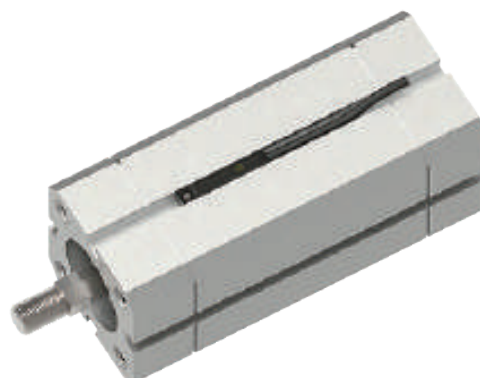
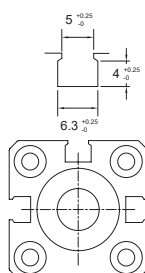

Unit : mm

# KT-58 SERIES



## Dimensions

KT-58R, KT-58N, KT-58P, KT-58RP / KT-58R-QD,  
KT-58N-QD, KT-58P-QD, KT-58RP-QD

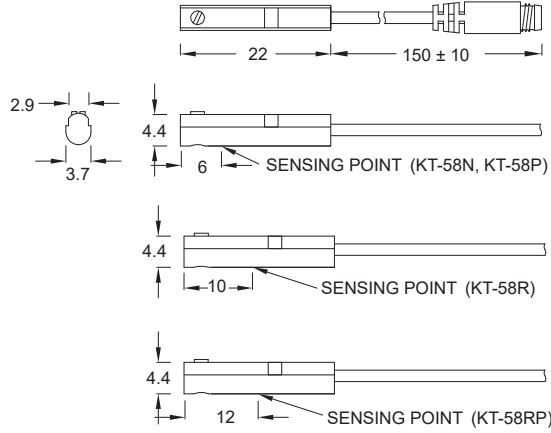

Unit : mm

## QD Pinout

### 3 wire QD wiring

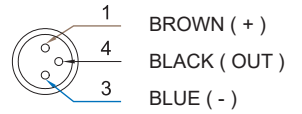

### 2 wire QD wiring

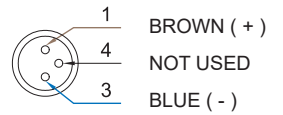

### 2 wire EQD wiring

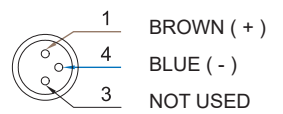

## Specifications

MODEL	KT-58R	KT-58N	KT-58P	KT-58RP
<b>Connect Diagram</b>				
<b>Characteristics</b>				
<b>Wiring Method</b>	2-Wire Type	3-Wire Type		
<b>Switching Logic</b>	SPST, Normally Open	Solid State Output, Normally Open		SPST, Normally Open
<b>Sensor Type</b>	Reed Switch	NPN Current Sinking	PNP Current Sourcing	Reed Switch
<b>Operating Voltage</b>	5 ~ 120 V DC / AC	10 ~ 30 V DC		10 ~ 30 V DC / AC
<b>Switching Current</b>	100 mA max.	200 mA max.		500 mA max.
<b>Contact Rating *1</b>	10 W max.	6 W max.		10 W max.
<b>Current Consumption</b>	-	10 mA @ 24 V DC max.		5 mA @ 24 V DC max.
<b>Voltage Drop</b>	3.5 V max.	0.5 V @ 50 mA max.		0.1 V @ 100 mA max.
<b>Leakage Current</b>	-	0.01 mA max.		-
<b>Indicator</b>	Red LED		Yellow LED	
<b>Cable</b>	ø2.5, 2C, PUR	ø2.5, 3C, PUR		
<b>Operating Frequency</b>	200 Hz	1000 Hz		200 Hz
<b>Magnet Requirement *2</b>	70 Gauss	40 Gauss		50 Gauss
<b>Temperature Range</b>	-10 ~ 70 °C			
<b>Shock *3</b>	30 G	50 G		30 G
<b>Vibration *4</b>	9 G			
<b>Enclosure Classification</b>	IEC 60529 IP67			
<b>Protection Circuit *5</b>	1	3, 4		1

### NOTE:

\*1 : WARNING : Never exceed rating ( Watt = Voltage x Amperage ).  
Permanent damage to sensor will occur.

\*2 : Measuring standard target : ø15.5 × ø8 × 5t ( Anisotropy rubber magnet )

\*3 : Sin wave / X , Y , Z 3 directions / 3 times each direction / 11 ms each time.

\*4 : Double amplitude 1.5 mm / 10 Hz ~ 55 Hz ~ 10 Hz ( Sweep 1 min ) / X , Y , Z 3 directions / 1 hour each time.

\*5 : 1 = None / 2 = Short-circuit / 3 = Power Source Reverse polarity / 4 = Surge Suppression

## Groove Dimensions

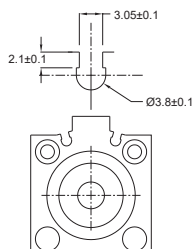

Unit : mm

# KT-59 SERIES



## Dimensions

KT-59R, KT-59N, KT-59P, KT-59RP /  
KT-59R-QD, KT-59N-QD, KT-59P-QD, KT-59RP-QD

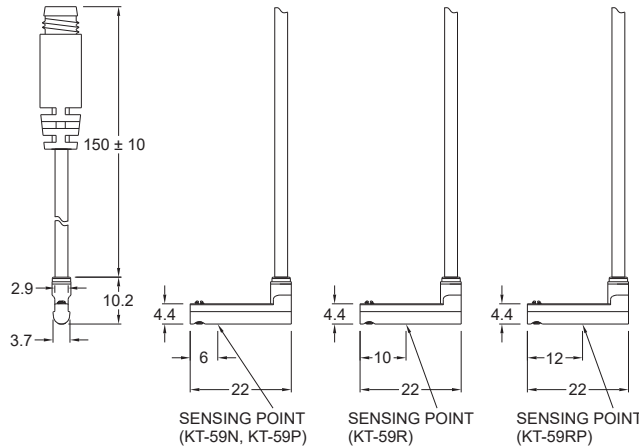

Unit : mm

## QD Pinout

### 3 wire QD wiring

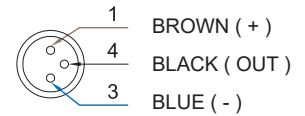

### 2 wire QD wiring

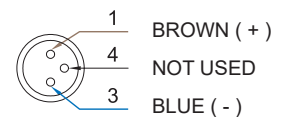

### 2 wire EQD wiring

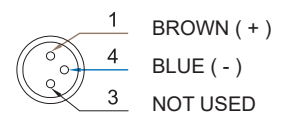

## Specifications

MODEL	KT-59R	KT-59N	KT-59P	KT-59RP
Connect Diagram				
Characteristics				
Wiring Method	2-Wire Type	3-Wire Type		
Switching Logic	SPST, Normally Open	Solid State Output, Normally Open		SPST, Normally Open
Sensor Type	Reed Switch	NPN Current Sinking	PNP Current Sourcing	Reed Switch
Operating Voltage	5 ~ 120 V DC / AC	10 ~ 30 V DC		10 ~ 30 V DC / AC
Switching Current	100 mA max.	200 mA max.		500 mA max.
Contact Rating *1	10 W max.	6 W max.		10 W max.
Current Consumption	-	10 mA @ 24 V DC max.		5 mA @ 24 V DC max.
Voltage Drop	3.5 V max.	0.5 V @ 50 mA max.		0.1 V @ 100 mA max.
Leakage Current	-	0.01 mA max.		-
Indicator	Red LED		Yellow LED	
Cable	ø2.5, 2C, PUR	ø2.5, 3C, PUR		
Operating Frequency	200 Hz	1000 Hz		200 Hz
Magnet Requirement *2	70 Gauss	40 Gauss		50 Gauss
Temperature Range	-10 ~ 70 °C			
Shock *3	30 G	50 G		30 G
Vibration *4	9 G			
Enclosure Classification	IEC 60529 IP67			
Protection Circuit *5	1	3, 4		1

### NOTE:

\*1 : WARNING : Never exceed rating ( Watt = Voltage x Amperage ).  
Permanent damage to sensor will occur.

\*2 : Measuring standard target : ø15.5 × ø8 × 5t ( Anisotropy rubber magnet )

\*3 : Sin wave / X , Y , Z 3 directions / 3 times each direction / 11 ms each time.

\*4 : Double amplitude 1.5 mm / 10 Hz ~ 55 Hz ~ 10 Hz ( Sweep 1 min ) / X , Y , Z 3 directions / 1 hour each time.

\*5 : 1 = None / 2 = Short-circuit / 3 = Power Source Reverse polarity / 4 = Surge Suppression

## Groove Dimensions

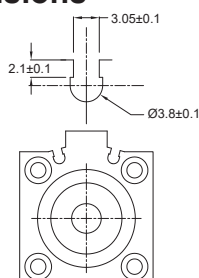

Unit : mm

# KT-65 SERIES



Patented

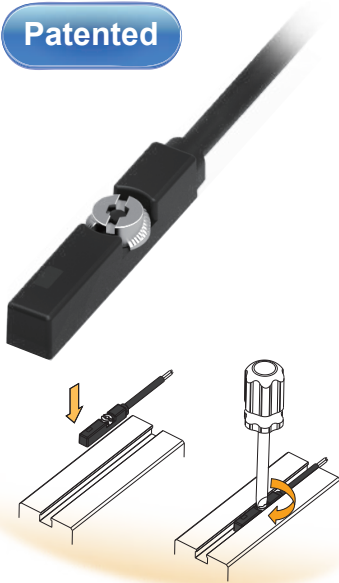

## Dimensions

KT-65D, KT-65DE, KT-65N, KT-65NE, KT-65P, KT-65PE /  
KT-65D-QD, KT-65DE-QD, KT-65N-QD, KT-65NE-QD,  
KT-65P-QD, KT-65PE-QD

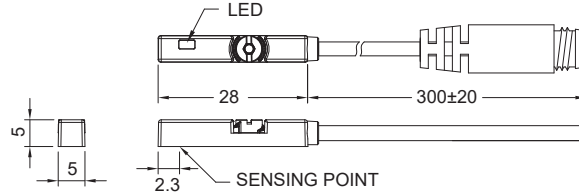

KT-65R, KT-65RP / KT-65R-QD, KT-65RP-QD

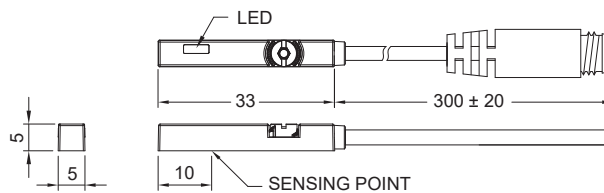

Unit : mm

## QD Pinout

### 3 wire QD wiring

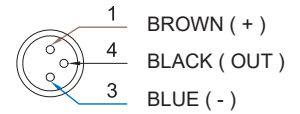

### 2 wire QD wiring

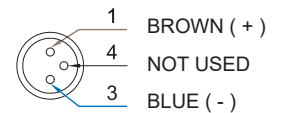

### 2 wire EQD wiring

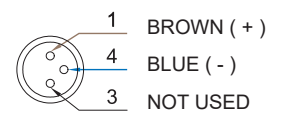

## Specifications

MODEL	KT-65R	KT-65D	KT-65DE	KT-65N	KT-65NE	KT-65P	KT-65PE	KT-65RP
<b>Connect Diagram</b>								
<b>Characteristics</b>	2-Wire Type		3-Wire Type					
<b>Wiring Method</b>	2-Wire Type		3-Wire Type					
<b>Switching Logic</b>	SPST, Normally Open	Solid State Output, Normally Open			SPST, Normally Open			
<b>Sensor Type</b>	Reed Switch	-		NPN Current Sinking		PNP Current Sourcing		Reed Switch
<b>Operating Voltage</b>	5 ~ 240 V DC / AC	10 ~ 28 V DC	5 ~ 30 V DC	10 ~ 28 V DC	5 ~ 30 V DC	10 ~ 28 V DC	5 ~ 30 V DC	10 ~ 30 V DC / AC
<b>Switching Current</b>	100 mA max.	50 mA max.		200 mA max.			500 mA max.	
<b>Contact Rating *1</b>	10 W max.	1.5 W max.		5.5 W max.	6 W max.	5.5 W max.	6 W max.	10 W max.
<b>Current Consumption</b>	-			10 mA @ 24 V DC max.	6 mA @ 24 V DC max.	10 mA @ 24 V DC max.	6 mA @ 24 V DC max.	10 mA @ 24 V DC max.
<b>Voltage Drop</b>	3.0 V max.	3.5 V max.	3.7 V max.	1.5 V max.	0.5 V @ 200 mA max.	1.5 V max.	0.5 V @ 200 mA max.	0.1 V @ 100 mA max.
<b>Leakage Current</b>	-	0.8 mA max.	0.1 mA (40 uA) max.	0.05 mA max.	0.01 mA max.	0.05 mA max.	0.01 mA max.	-
<b>Indicator</b>	Red LED					Yellow LED		
<b>Cable</b>	ø2.8, 2C, PUR			ø2.8, 3C, PUR				
<b>Operating Frequency</b>	200 Hz	1000 Hz max.			200 Hz			
<b>Magnet Requirement *2</b>	75 Gauss	50 Gauss	40 ~ 1000 Gauss	50 Gauss	40 ~ 1000 Gauss	50 Gauss	40 ~ 1000 Gauss	65 Gauss
<b>Temperature Range</b>	-10 ~ 70 °C							
<b>Shock *3</b>	30 G	50 G			30 G			
<b>Vibration *4</b>	9 G							
<b>Enclosure Classification</b>	IEC 60529 IP67							
<b>Protection Circuit *5</b>	1	2, 4	3, 4	2, 3, 4	3, 4	2, 3, 4	3, 4	1

**NOTE:**

\*1 : WARNING : Never exceed rating ( Watt = Voltage x Amperage ).  
Permanent damage to sensor will occur.

\*2 : Measuring standard target : ø15.5 × ø8 × 5t ( Anisotropy rubber magnet )

\*3 : Sin wave / X , Y , Z 3 directions / 3 times each direction / 11 ms each time.

\*4 : Double amplitude 1.5 mm / 10 Hz ~ 55 Hz ~ 10 Hz ( Sweep 1 min ) / X , Y , Z 3 directions / 1 hour each time.

\*5 : 1 = None / 2 = Short-circuit / 3 = Power Source Reverse polarity / 4 = Surge Suppression

## Groove Dimensions | Clamp / Bracket

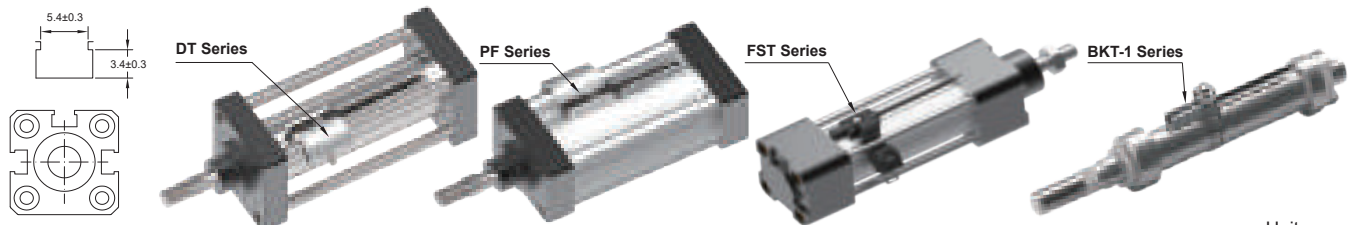

Unit : mm

# KT-65-EX SERIES



**Explosion Proof**

**Patented**

## Dimensions

KT-65N-EX, KT-65N-NC-EX, KT-65P-EX, KT-65P-NC-EX, KT-65D-EX

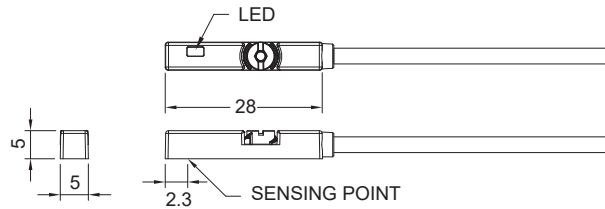

KT-65R-EX, KT-65RP-EX

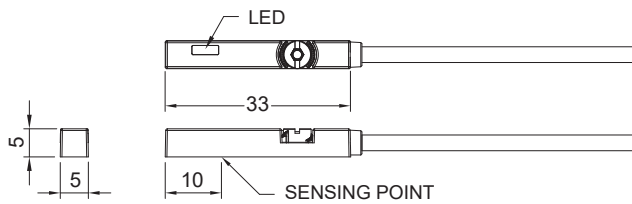

Unit : mm

**M8 Connector option is not available**

## Specifications

MODEL	KT-65R-EX	KT-65D-EX	KT-65N-EX	KT-65N-NC-EX	KT-65P-EX	KT-65P-NC-EX	KT-65RP-EX
<b>Connect Diagram</b>							
<b>Characteristics</b>	2-Wire Type		3-Wire Type				
<b>Wiring Method</b>	2-Wire Type		3-Wire Type				
<b>Switching Logic</b>	SPST, Normally Open	Solid State Output, Normally Open		Solid State Output, Normally Close	Solid State Output, Normally Open	Solid State Output, Normally Close	SPST, Normally Open
<b>Sensor Type</b>	Reed Switch	-	NPN Current Sinking		PNP Current Sourcing		Reed Switch
<b>Operating Voltage</b>	5 ~ 30 V DC / AC		10 ~ 28 V DC				10 ~ 30 V DC / AC
<b>Switching Current</b>	100 mA max.	50 mA max.	200 mA max.		500 mA max.		500 mA max.
<b>Contact Rating *1</b>	10 W max.	1.5 W max.	5.5 W max.		10 W max.		10 W max.
<b>Current Consumption</b>	-		10 mA @ 24 V DC max.				
<b>Voltage Drop</b>	3.0 V max.	3.5 V max.	1.5 V max.		0.1 V @ 100 mA max.		-
<b>Leakage Current</b>	-	0.8 mA max.	0.05 mA max.		-		
<b>Indicator</b>	Red LED				Yellow LED		
<b>Cable</b>	ø2.8, 2C, PUR		ø2.8, 3C, PUR				
<b>Operating Frequency</b>	200 Hz	1000 Hz		200 Hz		65 Gauss	
<b>Magnet Requirement *2</b>	65 Gauss	50 Gauss		30 G		9 G	
<b>Temperature Range</b>	-10 ~ 70 °C		IEC 60529 IP67				
<b>Shock *3</b>	30 G	50 G		30 G		1	
<b>Vibration *4</b>	9 G		1				
<b>Enclosure Classification</b>	1						
<b>Protection Circuit *5</b>	1	2	2, 3, 4		1		
<b>CE ATEX APPROVAL Baseefa14ATEX0118</b>	Ex ic IIB T4 Gc (-10 °C ≤ Ta ≤ +70 °C) Ex ic IIIC T135 °C Dc (-10 °C ≤ Ta ≤ +70 °C)						

**NOTE:**

\*1 : WARNING : Never exceed rating ( Watt = Voltage x Amperage ). Permanent damage to sensor will occur.

\*2 : Measuring standard target : ø15.5 × ø8 × 5t ( Anisotropy rubber magnet )

\*3 : Sin wave / X , Y , Z 3 directions / 3 times each direction / 11 ms each time.

\*4 : Double amplitude 1.5 mm / 10 Hz ~ 55 Hz ~ 10 Hz ( Sweep 1 min ) / X , Y , Z 3 directions / 1 hour each time.

\*5 : 1 = None / 2 = Short-circuit / 3 = Power Source Reverse polarity / 4 = Surge Suppression

## Groove Dimensions | Clamp / Bracket

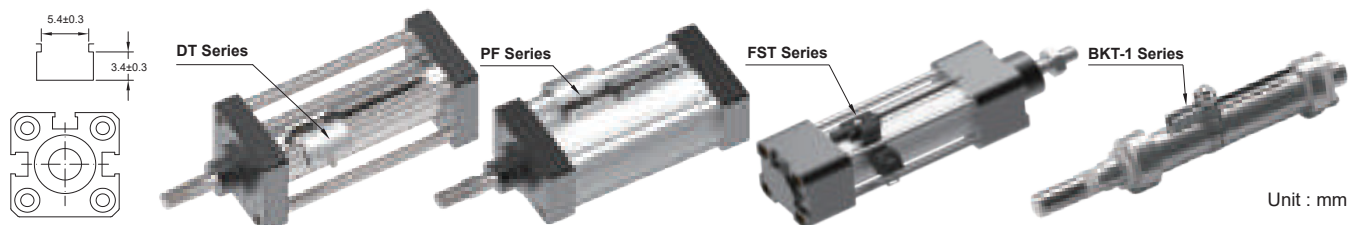

# KT-65-UL SERIES



Patented

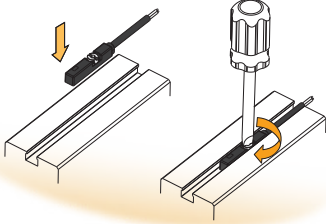

## Dimensions

KT-65N-UL, KT-65P-UL, KT-65D-UL

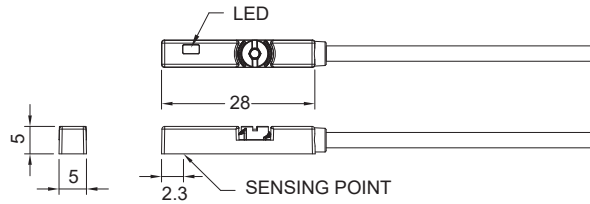

KT-65R-UL, KT-65RP-UL

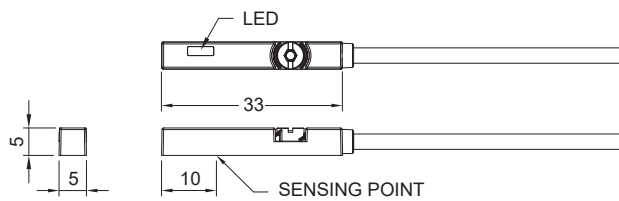

Unit : mm

M8 Connector option is not available

## Specifications

MODEL	KT-65R-UL	KT-65D-UL	KT-65N-UL	KT-65P-UL	KT-65RP-UL
Connect Diagram					
Characteristics					
Wiring Method	2-Wire Type		3-Wire Type		
Switching Logic	SPST, Normally Open		Solid State Output, Normally Open		SPST, Normally Open
Sensor Type	Reed Switch	-	NPN Current Sinking	PNP Current Sourcing	Reed Switch
Operating Voltage	5 ~ 30 V DC / AC		10 ~ 28 V DC		10 ~ 30 V DC / AC
Switching Current	60 mA max.	40 mA max.	100 mA max.		
Contact Rating *1	1.8 W max.	1.2 W max.	3 W max.		
Current Consumption	10 mA @ 24 V DC max.				
Voltage Drop	3.0 V max.	3.5 V max.	1.5 V max.		0.1 V @ 100 mA max.
Leakage Current	-	0.8 mA max.	0.05 mA max.		-
Indicator	Red LED			Yellow LED	
Cable	ø2.8, 2C, PUR		ø2.8, 3C, PUR		
Operating Frequency	200 Hz		1000 Hz		200 Hz
Magnet Requirement *2	75 Gauss		50 Gauss		65 Gauss
Temperature Range	-10 ~ 60 °C		-10 ~ 70 °C		
Shock *3	30 G		50 G		30 G
Vibration *4	9 G				
Enclosure Classification	IEC 60529 IP67				
Protection Circuit *5	1	2	2, 3, 4		1

**NOTE:**

\*1 : WARNING : Never exceed rating ( Watt = Voltage x Amperage ).  
Permanent damage to sensor will occur.

\*2 : Measuring standard target : ø15.5 × ø8 × 5t ( Anisotropy rubber magnet )

\*3 : Sin wave / X , Y , Z 3 directions / 3 times each direction / 11 ms each time.

\*4 : Double amplitude 1.5 mm / 10 Hz ~ 55 Hz ~ 10 Hz ( Sweep 1 min ) / X , Y , Z 3 directions / 1 hour each time.

\*5 : 1 = None / 2 = Short-circuit / 3 = Power Source Reverse polarity / 4 = Surge Suppression

## Groove Dimensions | Clamp / Bracket

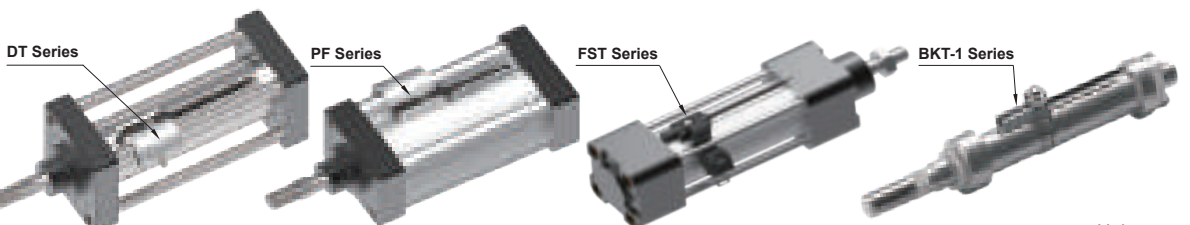
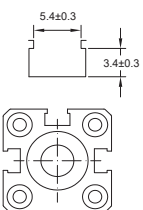

Unit : mm

# KT-71 SERIES



## Dimensions

KT-71D, KT-71N, KT-71P /  
KT-71D-QD, KT-71N-QD, KT-71P-QD

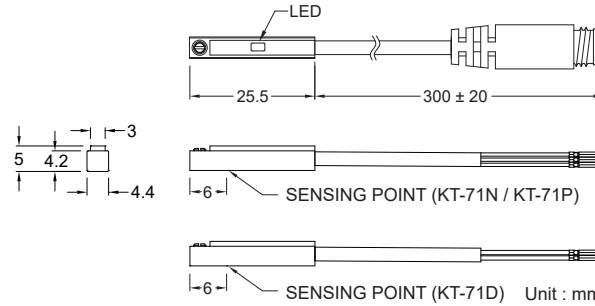

## SW Out

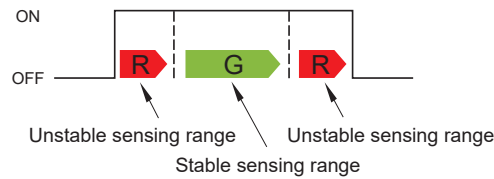

- Dual Color LED allow more precise positioning

## QD Pinout

- 3 wire QD wiring

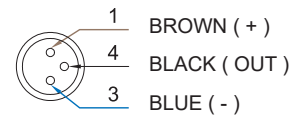

- 2 wire QD wiring

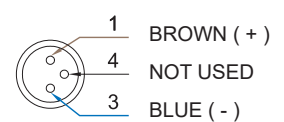

- 2 wire EQD wiring

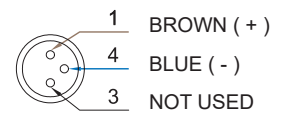

## Specifications

MODEL	KT-71D	KT-71N	KT-71P
<b>Connect Diagram</b>			
<b>Characteristics</b>			
<b>Wiring Method</b>	2-Wire Type	3-Wire Type	
<b>Switching Logic</b>	Solid State Output, Normally Open		
<b>Sensor Type</b>	-	NPN Current Sinking	PNP Current Sourcing
<b>Operating Voltage</b>	10 ~ 28 V DC		
<b>Switching Current</b>	80 mA max.		
<b>Contact Rating *1</b>	2 W max.		
<b>Current Consumption</b>	-	10 mA @ 24 V DC max.	
<b>Voltage Drop</b>	4 V max.	1.5 V max.	
<b>Leakage Current</b>	1 mA max.	0.05 mA max.	
<b>Indicator</b>	Red LED : unstable sensing range ; Green LED : stable sensing range		
<b>Cable</b>	ø2.8, 2C, PUR	ø2.8, 3C, PUR	
<b>Operating Frequency</b>	1000 Hz		
<b>Magnet Requirement *2</b>	85 Gauss		
<b>Temperature Range</b>	-10 ~ 60 °C		
<b>Shock *3</b>	50 G		
<b>Vibration *4</b>	9 G		
<b>Enclosure Classification</b>	IEC 60529 IP67		
<b>Protection Circuit *5</b>	2, 3, 4		

### NOTE:

\*1 : WARNING : Never exceed rating ( Watt = Voltage x Amperage ).  
Permanent damage to sensor will occur.

\*2 : Measuring standard target : ø15.5 × ø8 × 5t ( Anisotropy rubber magnet )

\*3 : Sin wave / X , Y , Z 3 directions / 3 times each direction / 11 ms each time.

\*4 : Double amplitude 1.5 mm / 10 Hz ~ 55 Hz ~ 10 Hz ( Sweep 1 min ) / X , Y , Z 3 directions / 1 hour each time.

\*5 : 1 = None / 2 = Short-circuit / 3 = Power Source Reverse polarity / 4 = Surge Suppression

## Groove Dimensions

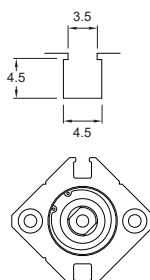

Unit : mm

# KT-75 SERIES



Patented



## Dimensions

KT-75D, KT-75N, KT-75P / KT-75D-QD, KT-75N-QD, KT-75P-QD

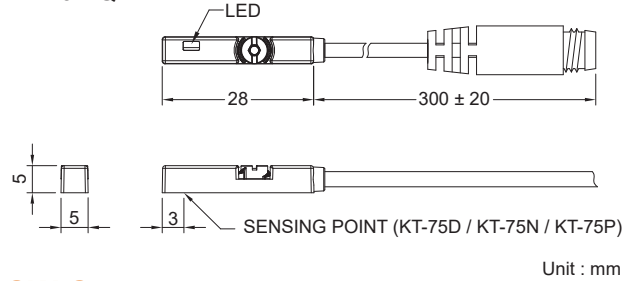

## SW Out

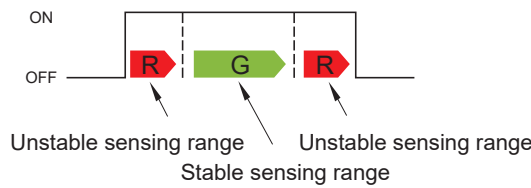

## QD Pinout

### 3 wire QD wiring

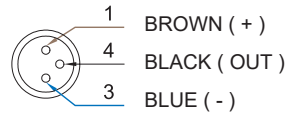

### 2 wire QD wiring

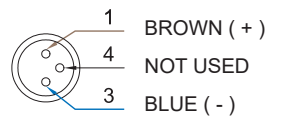

### 2 wire EQD wiring

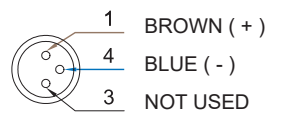

- Dual Color LED allow more precise positioning

## Specifications

MODEL	KT-75D	KT-75N	KT-75P
Connect Diagram			
Characteristics			
Wiring Method	2-Wire Type	3-Wire Type	
Switching Logic	Solid State Output, Normally Open		
Sensor Type	-	NPN Current Sinking	PNP Current Sourcing
Operating Voltage	10 ~ 28 V DC		
Switching Current	80 mA max.		
Contact Rating *1	2 W max.		
Current Consumption	-	10 mA @ 24 V DC max.	
Voltage Drop	4 V max.	1.5 V max.	
Leakage Current	1 mA max.	0.05 mA max.	
Indicator	Red LED : unstable sensing range ; Green LED : stable sensing range		
Cable	ø2.8, 2C, PUR	ø2.8, 3C, PUR	
Operating Frequency	1000 Hz		
Magnet Requirement *2	85 Gauss		
Temperature Range	-10 ~ 60 °C		
Shock *3	50 G		
Vibration *4	9 G		
Enclosure Classification	IEC 60529 IP67		
Protection Circuit *5	2, 3, 4		

### NOTE:

\*1 : WARNING : Never exceed rating ( Watt = Voltage x Amperage ).  
Permanent damage to sensor will occur.

\*2 : Measuring standard target : ø15.5 × ø8 × 5t ( Anisotropy rubber magnet )

\*3 : Sin wave / X , Y , Z 3 directions / 3 times each direction / 11 ms each time.

\*4 : Double amplitude 1.5 mm / 10 Hz ~ 55 Hz ~ 10 Hz ( Sweep 1 min ) / X , Y , Z 3 directions / 1 hour each time.

\*5 : 1 = None / 2 = Short-circuit / 3 = Power Source Reverse polarity / 4 = Surge Suppression

## Groove Dimensions

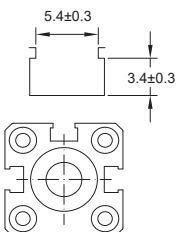

## Clamp

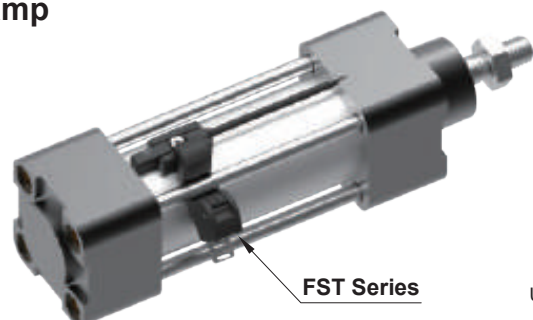

Unit : mm

# KT-77 SERIES



## Dimensions

KT-77D, KT-77N, KT-77P /  
KT-77D-QD, KT-77N-QD, KT-77P-QD

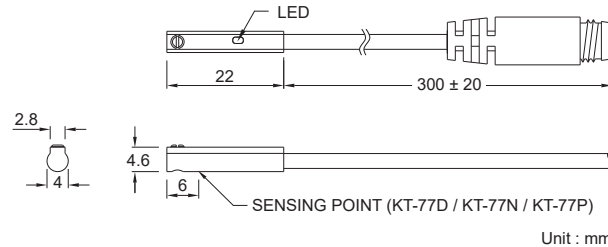

## SW Out

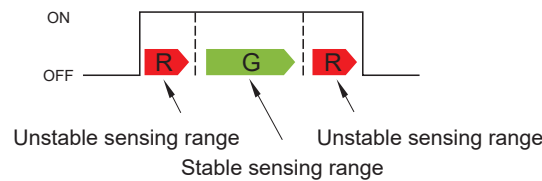

## QD Pinout

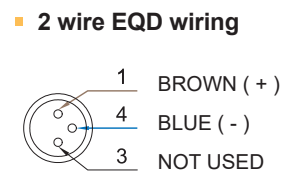
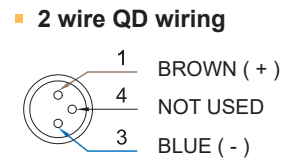
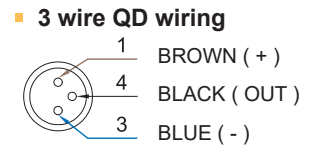

- Dual Color LED allow more precise positioning

## Specifications

MODEL	KT-77D	KT-77N	KT-77P
<b>Connect Diagram</b>			
<b>Characteristics</b>	Solid State Output, Normally Open		
<b>Wiring Method</b>	2-Wire Type	3-Wire Type	
<b>Switching Logic</b>	Solid State Output, Normally Open		
<b>Sensor Type</b>	-	NPN Current Sinking	PNP Current Sourcing
<b>Operating Voltage</b>	10 ~ 28 V DC		
<b>Switching Current</b>	80 mA max.		
<b>Contact Rating *1</b>	2 W max.		
<b>Current Consumption</b>	-	10 mA @ 24 V DC max.	
<b>Voltage Drop</b>	4 V max.	1.5 V max.	
<b>Leakage Current</b>	1 mA max.	0.05 mA max.	
<b>Indicator</b>	Red LED : unstable sensing range ; Green LED : stable sensing range		
<b>Cable</b>	ø2.8, 2C, PUR	ø2.8, 3C, PUR	
<b>Operating Frequency</b>	1000 Hz		
<b>Magnet Requirement *2</b>	85 Gauss		
<b>Temperature Range</b>	-10 ~ 60 °C		
<b>Shock *3</b>	50 G		
<b>Vibration *4</b>	9 G		
<b>Enclosure Classification</b>	IEC 60529 IP67		
<b>Protection Circuit *5</b>	2, 3, 4		

### NOTE:

\*1 : WARNING : Never exceed rating ( Watt = Voltage x Amperage ).  
Permanent damage to sensor will occur.

\*2 : Measuring standard target : ø15.5 × ø8 × 5t ( Anisotropy rubber magnet )

\*3 : Sin wave / X , Y , Z 3 directions / 3 times each direction / 11 ms each time.

\*4 : Double amplitude 1.5 mm / 10 Hz ~ 55 Hz ~ 10 Hz ( Sweep 1 min ) / X , Y , Z 3 directions / 1 hour each time.

\*5 : 1 = None / 2 = Short-circuit / 3 = Power Source Reverse polarity / 4 = Surge Suppression

## Groove Dimensions

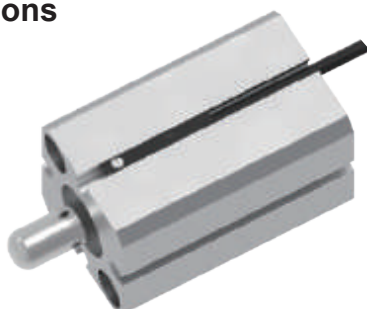
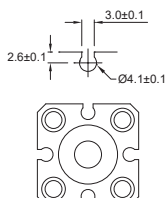

## Clamp



Unit : mm

# KT-1000D SERIES

## Weld-Field Immune Sensor



### Magnetic Field Resistant



- Dual Color LED allow more precise positioning

### Dimensions

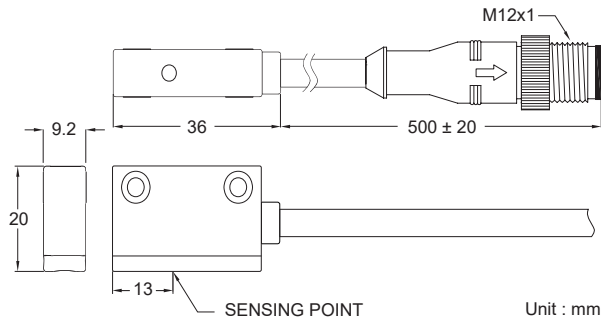

### SW Out

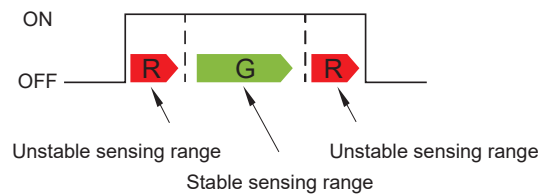

### QD Pinout

#### QD

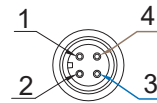

- 1 : N / C ( No connect )
- 2 : N / C ( No connect )
- 3 : BLUE
- 4 : BROWN

#### EQD

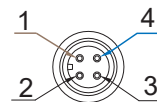

- 1 : BROWN
- 2 : N / C ( No connect )
- 3 : N / C ( No connect )
- 4 : BLUE

### Specifications

MODEL	KT-1000D
Connect Diagram	
Characteristics	
Wiring Method	2-Wire Type
Switching Logic	Solid State Output, Normally Open
Sensor Type	-
Operating Voltage	10 ~ 28 V DC
Switching Current	5 ~ 50 mA max.
Contact Rating *1	1.5 W max.
Current Consumption	-
Voltage Drop	5 V max.
Leakage Current	1 mA max.
Indicator	Red LED : unstable sensing range ; Green LED : stable sensing range
Cable	ø 5.4, 2C, PVC
Operating Time	50 ms max.
Magnetic Field Resistance *2	16000 A
Magnet Requirement *3	85 Gauss
Temperature Range	-10 ~ 60 °C
Shock *4	30 G
Vibration *5	9 G
Enclosure Classification	IEC 60529 IP67
Protection Circuit *6	3, 4

#### NOTE :

- \* 1 : WARNING : Never exceed rating ( Watt = Voltage × Amperage ). Permanent damage to sensor will occur.
- \* 2 : The operational distance can be 0 mm between KT-1000D and welding gun ( welding conductor or cable ) when the welding current less than 16000 A.
- \* 3 : Measuring standard target : ø15.5 × ø8 × 5t ( Anisotropy rubber magnet )
- \* 4 : Sin wave / X, Y, Z 3 directions / 3 times each direction / 11 ms each time.
- \* 5 : Double amplitude 1.5 mm / 10 Hz ~ 55 Hz ~ 10 Hz ( Sweep 1 min ) / X, Y, Z 3 directions / 1 hour each time.
- \* 6 : 1 = None / 2 = Short-circuit / 3 = Power Source Reverse polarity / 4 = Surge Suppression

### Ordering Information

KT - 1000D -

#### Cable Length / Connector

- Blank : With 3 meter cable
- QD : With M12 4Pin male connector

### Application Mounting

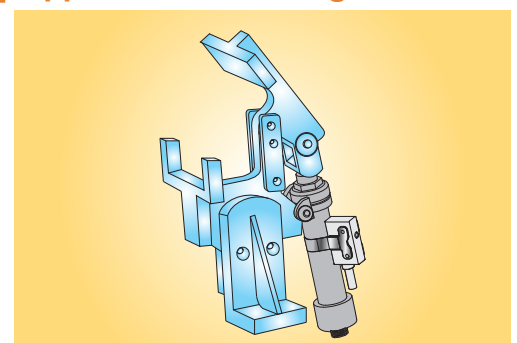

- KT-1000D detects the position of the cylinder piston and it is especially suitable for clamp cylinder.

## BP Clamp

Clamp is designed for mounting KT-1000D on round cylinder.

### How To Mount

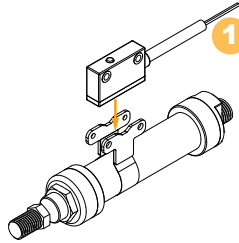

#### 1 Step 1

Wrap the band around cylinder, and place sensor on cylinder.

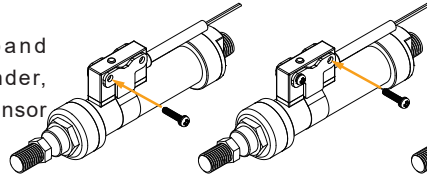

#### 2 Step 2

Insert screw into clamp. Adjust sensor to the sensing position and tighten.

**B P - 4 0 4 5**

#### Cylinder I.D.

- 40 : Ø40 round cylinder
- 50 : Ø50 round cylinder
- 63 : Ø63 round cylinder

#### Cylinder O.D.

- 45 : Ø45 round cylinder
- 47 : Ø47 round cylinder
- ⋮
- 72 : Ø72 round cylinder

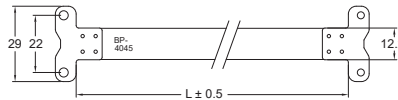

### Cylinder Chart

MODEL	"L"	I.D.	O.D.
BP-4045	154	Ø40	Ø45
BP-4047	161	Ø40	Ø47
BP-5055	188	Ø50	Ø55
BP-5058	197	Ø50	Ø58
BP-6368	228	Ø63	Ø68
BP-6372	240	Ø63	Ø72

Unit : mm

## PMB Bracket

Bracket is designed for mounting KT-1000D on round cylinder.

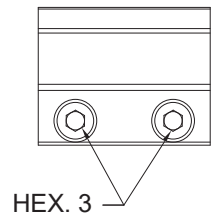
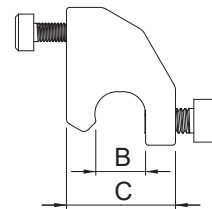
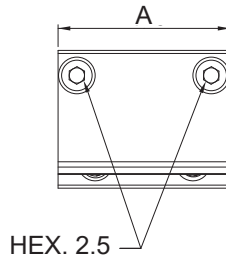
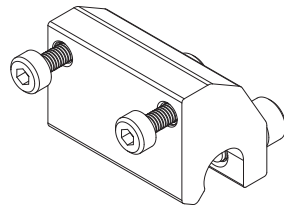
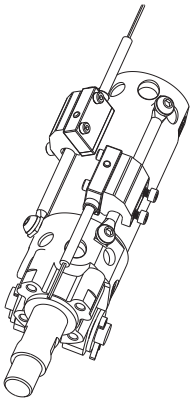

MODEL	DIM.	A	B	C
PMB-040		28.15	8.15	17.85

Unit : mm

## Application Environment



- KT-1000D can be applied in the strong magnetic field environment such as automotive manufacturing or areas near welding machine.
- When KT-1000D detects the magnetic AC field ( 50 or 60 Hz ) it will keep the status of output and will not be effected.

## Weld-Field Immune

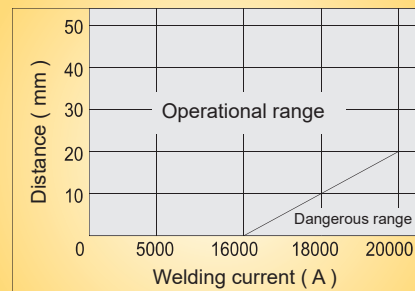

- The operational distance can be 0 mm between KT-1000D and welding gun ( welding conductor or cable ) when the welding current less than 16000 A.

# KT-1001D SERIES

## Weld-Field Immune Sensor



Magnetic Field Resistant

### Dimensions

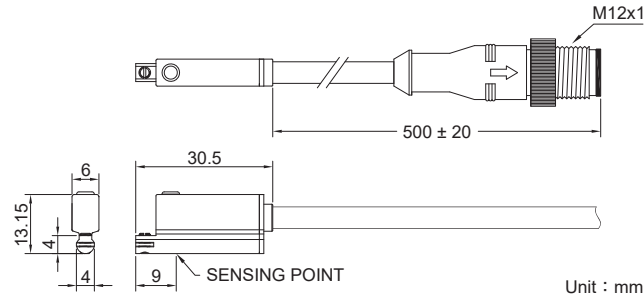

### QD Pinout

#### QD

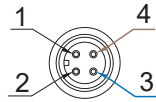

- 1 : N / C ( No connect )
- 2 : N / C ( No connect )
- 3 : BLUE
- 4 : BROWN

#### EQD

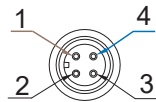

- 1 : BROWN
- 2 : N / C ( No connect )
- 3 : N / C ( No connect )
- 4 : BLUE

### SW Out

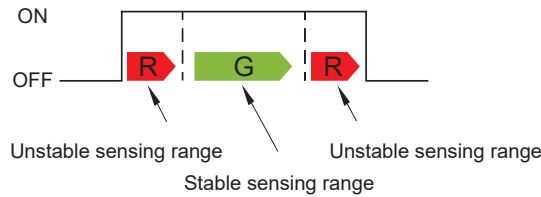

- Dual Color LED allow more precise positioning

### Specifications

MODEL	KT-1001D
Connect Diagram	
Characteristics	
Wiring Method	2-Wire Type
Switching Logic	Solid State Output, Normally Open
Sensor Type	-
Operating Voltage	10 ~ 28 V DC
Switching Current	5 ~ 50 mA max.
Contact Rating *1	1.5 W max.
Current Consumption	-
Voltage Drop	5V max.
Leakage Current	1mA max.
Indicator	Red LED : unstable sensing range ; Green LED : stable sensing range
Cable	ø 4.8, 2C, PVC
Operating Time	50 ms max.
Magnetic Field Resistance *2	16000 A
Magnet Requirement *3	85 Gauss
Temperature Range	-10 ~ 60 °C
Shock *4	50 G
Vibration *5	9 G
Enclosure Classification	IEC 60529 IP67
Protection Circuit *6	3, 4

#### NOTE :

\* 1 : WARNING : Never exceed rating ( Watt = Voltage × Amperage ). Permanent damage to sensor will occur.

\* 2 : The operational distance can be 0 mm between KT-1001D and welding gun ( welding conductor or cable ) when the welding current less than 16000 A.

\* 3 : Measuring standard target : ø15.5 × ø8 × 5t ( Anisotropy rubber magnet )

\* 4 : Sin wave / X , Y , Z 3 directions / 3 times each direction / 11 ms each time.

\* 5 : Double amplitude 1.5 mm / 10 Hz ~ 55 Hz ~ 10 Hz ( Sweep 1 min ) / X , Y , Z 3 directions / 1 hour each time.

\* 6 : 1 = None / 2 = Short-circuit / 3 = Power Source Reverse polarity / 4 = Surge Suppression

### Ordering Information

KT - 1001D -

#### Cable Length / Connector

- Blank: With 3 meter cable
- QD: With M12 4Pin male connector

### Groove Dimensions

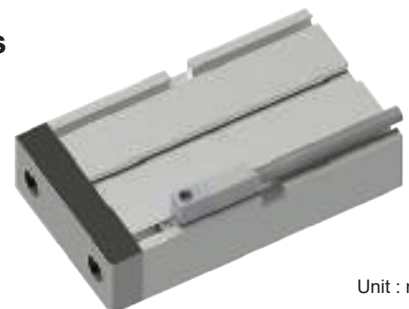
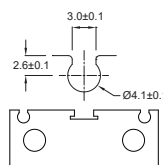

Unit : mm

## PM Series

Bracket is designed for mounting KT-20 & KT-21 & KT-31 series sensor on Tie-Rod cylinder.

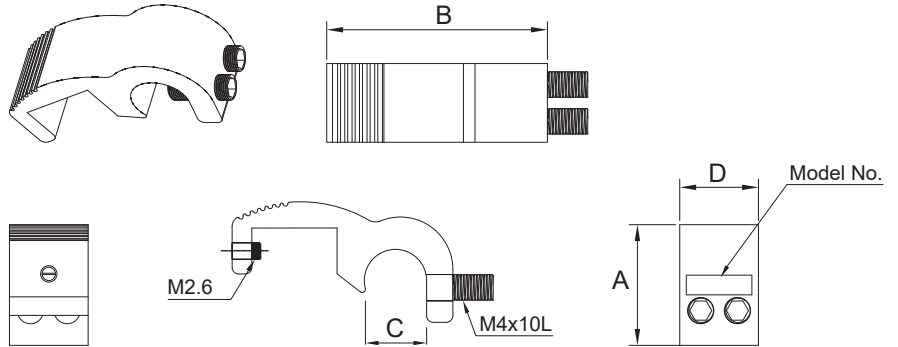
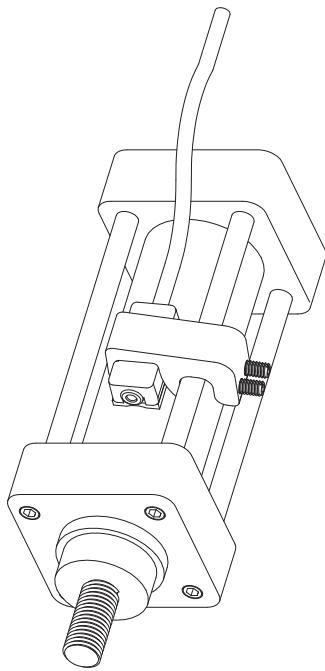

MODEL	DIM.	A	B	C	D
PM-6		19.1	31.8	7.3	12
PM-8		18.4	33.7	9.3	12
PM-10		16.7	35.9	11.2	12
PM-12		20	35.5	11.5	12
PM-14		24	38.0	13.5	12
PM-16		24	40.0	15.5	12

Unit : mm

## PI Series

Bracket is designed for mounting KT-20 & KT-21 & KT-31 series sensor on ISO profile cylinder.

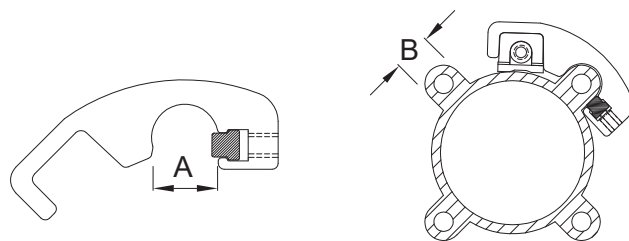
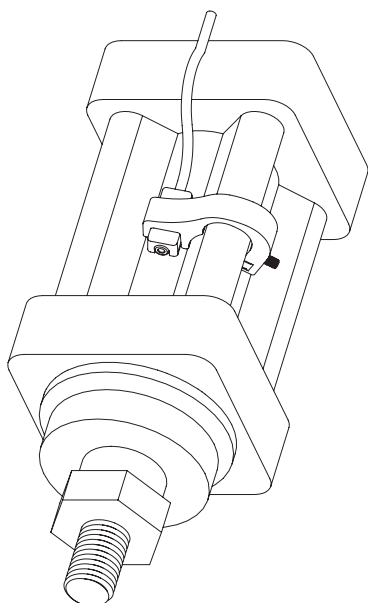

MODEL	DIM.	A	B	Remark
PI-1		10.9	10.4	Ø 32 ~ Ø 40
PI-2		14.10	13.5	Ø 50 ~ Ø 63
PI-3		15.45	15	Ø 80
PI-4		16.3	16	Ø 100
PI-5		19.8	18.7	Ø 125
PI-6		26.5	25.7	Ø 150

Unit : mm

## PF Series

Bracket is designed for mounting KT-32 & KT-40 & KT-50 & KT-65 & KT-75 series sensor on ISO profile cylinder.

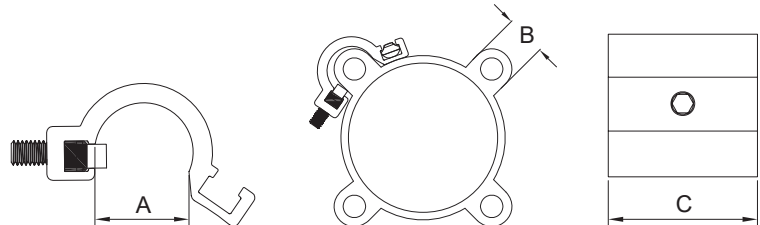
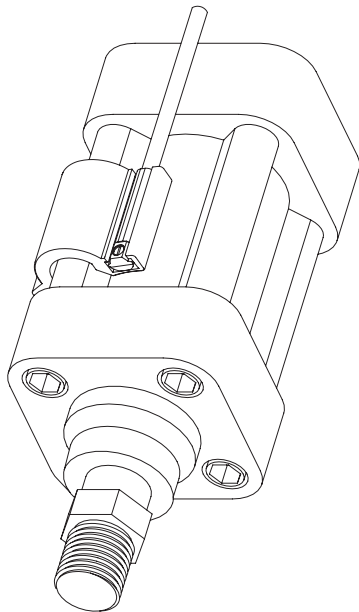

MODEL	DIM.	A	B	C	Remark
PF-1		12.1	10.4	25	Ø 32 ~ Ø 40
PF-2		15.9	13.5	25	Ø 50 ~ Ø 63
PF-3		16.3	15	25	Ø 80
PF-4		17.9	16	25	Ø 100
PF-5		19.7	18.7	25	Ø 125

Unit : mm

## DT Series

Bracket is designed for mounting KT-32 & KT-40 & KT-50 & KT-65 & KT-75 series sensor on Tie-Rod cylinder.

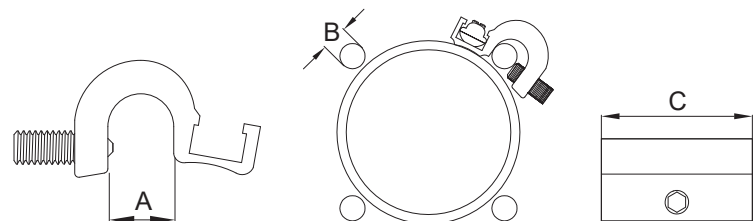
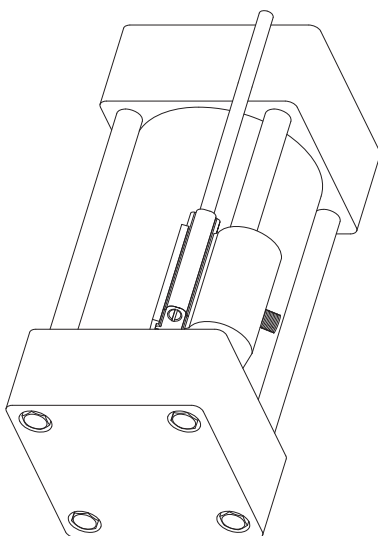

MODEL	DIM.	A	B	C
DT-1		7.9	Ø 4 ~ Ø 6	25
DT-2		10.4	Ø 8 ~ Ø 10	25
DT-3		15.1	Ø 12 ~ Ø 14	25
DT-4		20.6	Ø 16	25
DT-5		24.9	Ø 20 ~ Ø 24	30

Unit : mm

# BRACKET SERIES



## PF7 Series

Bracket is designed for mounting KT-07 & KT-16 & KT-36 & KT-37 & KT-38 & KT-77 series sensor on ISO profile cylinder.

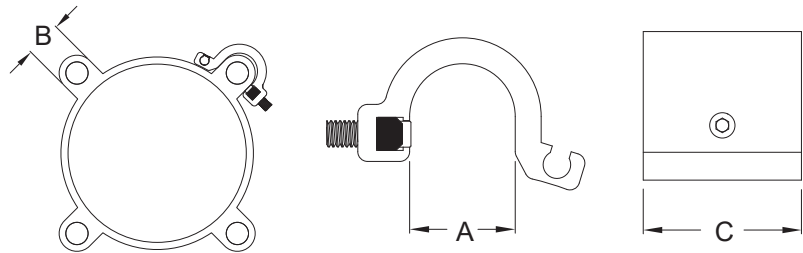
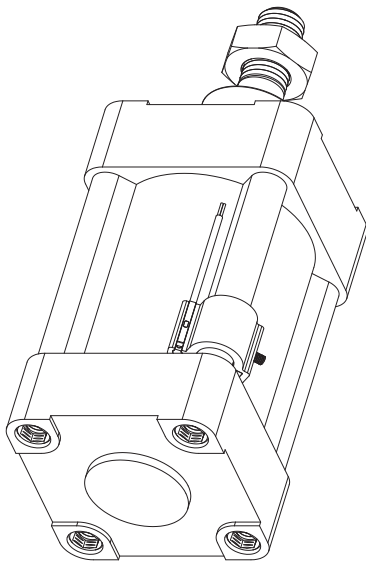

MODEL	DIM.	A	B	C	Remark
PF7-1		12.1	10.4	25	Ø 32 ~ Ø 40
PF7-2		15.9	13.5	25	Ø 50 ~ Ø 63
PF7-3		16.3	15	25	Ø 80
PF7-4		17.9	16	25	Ø 100
PF7-5		19.7	18.7	25	Ø 125
PF7-6		27.6	25.7	25	Ø 160

Unit : mm

## DT7 Series

Bracket is designed for mounting KT-07 & KT-16 & KT-36 & KT-37 & KT-38 & KT-77 series sensor on Tie-Rod cylinder.

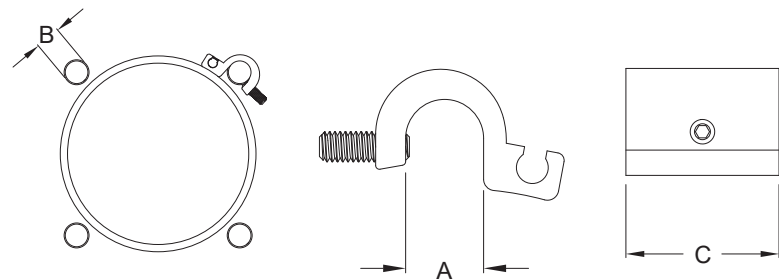
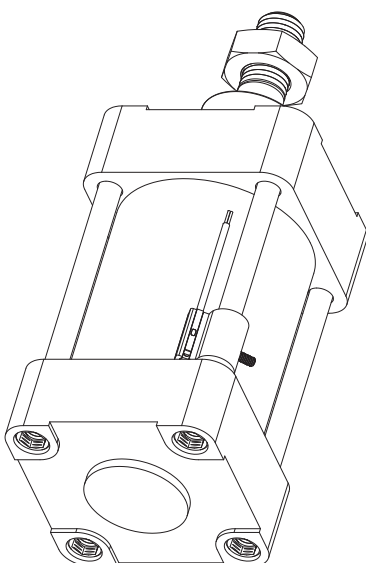

MODEL	DIM.	A	B	C
DT7-1		7.9	Ø 4 ~ Ø 6	25
DT7-2		10.4	Ø 8 ~ Ø 10	25
DT7-3		15.1	Ø 12 ~ Ø 14	25
DT7-4		20.6	Ø 16	25

Unit : mm

## PB Series

PB-01 & PB-03 bracket is designed for mounting KT-07 & KT-16 & KT-1001D series sensor on T-slot cylinder. PB-12 bracket is designed for mounting KT-07 & KT-16 & KT-36 & KT-37 & KT-38 & KT-77 & KT-1001D series sensor on T-slot cylinder.

### ■ PB-01 & PB-03

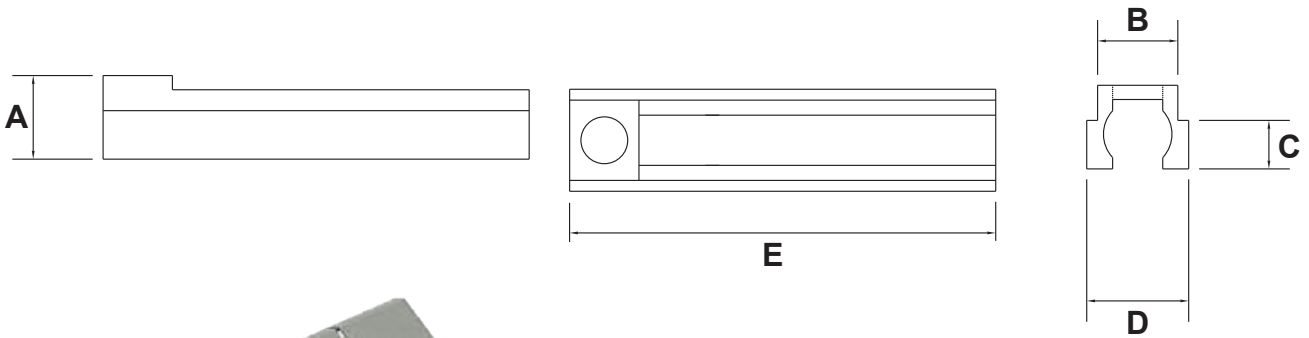

MODEL	DIM.	A	B	C	D	E	Groove Dimensions
PB-01		5.0	4.8	2.9	6.1	25.5	
PB-03		5.0	4.8	3.8	6.1	25.5	

Unit : mm

### ■ PB-12

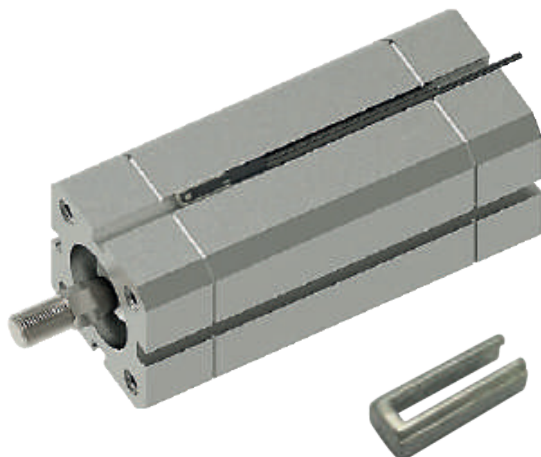
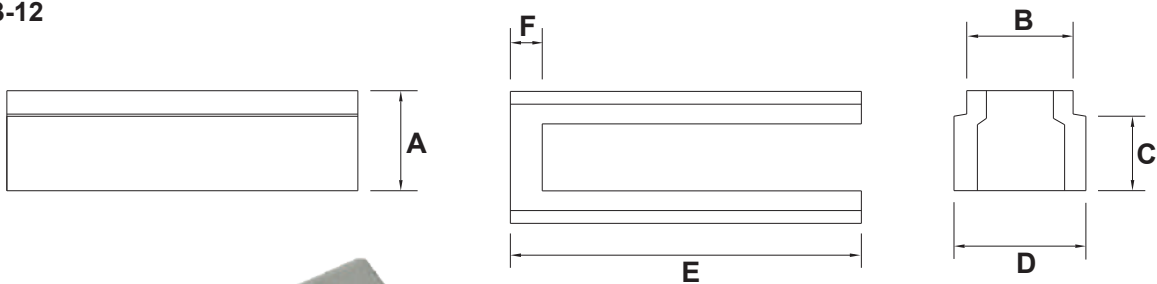

MODEL	DIM.	A	B	C	D	E	F	Groove Dimensions
PB-12		4.7	5.0	3.5	6.2	16.5	1.5	

Unit : mm

# CLAMP SERIES



## PN Series

Clamp is designed for mounting KT-20 & KT-21 series sensor on round cylinder.

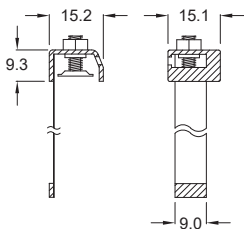

### 1 Step 1

Loosen screw & nut.

### 2 Step 2

Wrap the band around the cylinder & put the apex through the fastening hole.

### 3 Step 3

Pull up mounting head & place sensor under the mounting head.

### 4 Step 4

Swivel set screw to tighten band and fixing sensor. Finally swivel nut for steadying.

## How To Mount

### Cylinder Chart

Model	Bore Size	Barrel Material	Model	Bore Size	Barrel Material
PN-A16	Ø16	Aluminum	PN-S10	Ø10	Stainless
PN-A20	Ø20	Aluminum	PN-S12	Ø12	Stainless
PN-A25	Ø25	Aluminum	PN-S16	Ø16	Stainless
PN-A30	Ø30	Aluminum	PN-S20	Ø20	Stainless
PN-A32	Ø32	Aluminum	PN-S25	Ø25	Stainless
PN-A40	Ø40	Aluminum	PN-S32	Ø32	Stainless
PN-A50	Ø50	Aluminum	PN-S40	Ø40	Stainless
PN-A63	Ø63	Aluminum			

Unit : mm

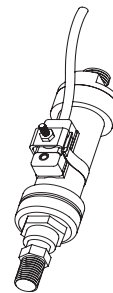

PN - S 2 0

### Barrel Material

S : Stainless steel  
A : Aluminum alloy

### Bore Size

10 : Ø10 round cylinder  
12 : Ø12 round cylinder  
...  
40 : Ø40 round cylinder

## PH Series

Clamp is designed for mounting KT-20 & KT-21 series sensor on round cylinder.

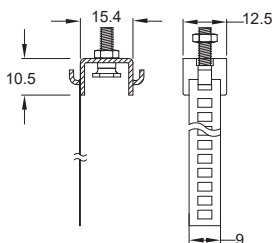

### 1 Step 1

Loosen screw & nut.

### 2 Step 2

Place sensor & wrap the band around the cylinder. Position the hook with the nearest hole on the band and mark the hole with a permanent marker.

### 3 Step 3

Remove mounting assembly. Cut the band at the nearest edge of next hole. (the one that's further away from the mounting head).

### 4 Step 4

Re-place the sensor & mounting assembly. Wrap the band & put the chosen hole on hook. Position the switch and tighten. Finally swivel nut for steadying.

## How To Mount

PH - 1

### Band No.

1 : For Ø6 ~ Ø63 round cylinder use.  
2 : For Ø6 ~ Ø125 round cylinder use.

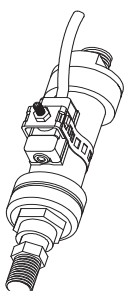

# CLAMP SERIES



## BK Series

Clamp is designed for mounting KT-05 & KT-15 series sensor on round cylinder.

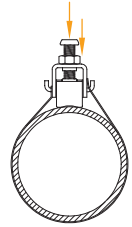
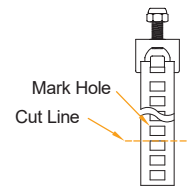
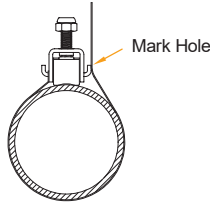
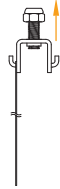
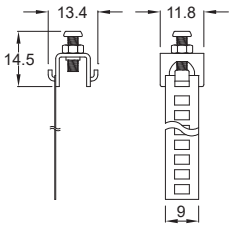

### How To Mount

#### 1 Step 1

Loosen screw & nut.

#### 2 Step 2

Place sensor & wrap the band around the cylinder.  
Position the hook with the nearest hole on the band and mark the hole with a permanent marker.

#### 3 Step 3

Remove mounting assembly.  
Cut the band at the nearest edge of next hole. (the one that's further away from the mounting head).

#### 4 Step 4

Re-place the sensor & mounting assembly.  
Wrap the band & put the chosen hole on hook.  
Position the switch and tighten.  
Finally swivel nut for steadying.

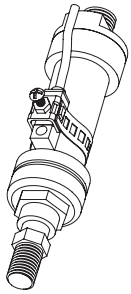

B K - **8 1**

#### Band No.

- 81 : For  $\varnothing 6 \sim \varnothing 32$  round cylinder use.
- 82 : For  $\varnothing 6 \sim \varnothing 63$  round cylinder use.

## BS Series

Clamp is designed for mounting KT-48 series sensor on round cylinder.

### How To Mount

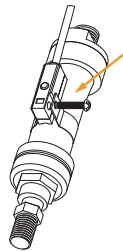
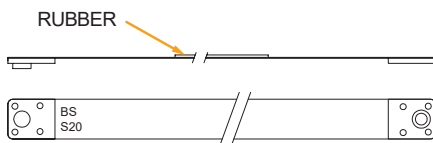

Wrap the band around cylinder barrel and re-insert screw head into clamp.

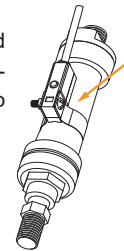

Position the switch and tighten.

B S - **S 2 5**

#### Barrel Material

- S : Stainless steel
- A : aluminum alloy

#### Bore Size

- 6 :  $\varnothing 6$  round cylinder
- 8 :  $\varnothing 8$  round cylinder
- ...
- 40 :  $\varnothing 40$  round cylinder

#### Cylinder Chart

Model	Bore Size	Barrel Material	O.D. (mm)	Model	Bore Size	Barrel Material	O.D. (mm)
BS-A20	$\varnothing 20$	Aluminum	25	BS-S6	$\varnothing 6$	Stainless	8.5
BS-A25	$\varnothing 25$	Aluminum	30	BS-S8	$\varnothing 8$	Stainless	10
BS-A30	$\varnothing 30$	Aluminum	35	BS-S10	$\varnothing 10$	Stainless	11
BS-A32	$\varnothing 32$	Aluminum	37	BS-S12	$\varnothing 12$	Stainless	13.2
BS-A40	$\varnothing 40$	Aluminum	45	BS-S16	$\varnothing 16$	Stainless	17
BS-A50	$\varnothing 50$	Aluminum	55	BS-S20	$\varnothing 20$	Stainless	21.6
BS-A63	$\varnothing 63$	Aluminum	70	BS-S25	$\varnothing 25$	Stainless	26.5
BS-A80	$\varnothing 80$	Aluminum	87.7	BS-S32	$\varnothing 32$	Stainless	33.6
				BS-S40	$\varnothing 40$	Stainless	42

Unit : mm

## BL-1 Series

Clamp is designed for mounting KT-40 & KT-50 series sensor on round cylinder.

### Cylinder Chart

Bore Size	Barrel Material	O.D. (mm)	Recommended mounting hole	Bore Size	Barrel Material	O.D. (mm)	Recommended mounting hole
Ø10	Stainless	11	10	Ø30	Aluminum	35	26
Ø12	Stainless	13.2	11	Ø32	Stainless	33.6	24
Ø16	Stainless	17	14	Ø32	Aluminum	37	27
Ø20	Stainless	21.6	16	Ø40	Stainless	42	30
Ø20	Aluminum	25	19	Ø40	Aluminum	45	32
Ø25	Stainless	26.5	20	Ø50	Aluminum	55	40
Ø25	Aluminum	30	22	Ø63	Aluminum	70	50



### How To Mount

**Example :** Use with Ø40 stainless body cylinder.

#### 1 Step 1

Refer to the cylinder chart, make marking next to the 30th hole. ( On the 31st hole, see below )

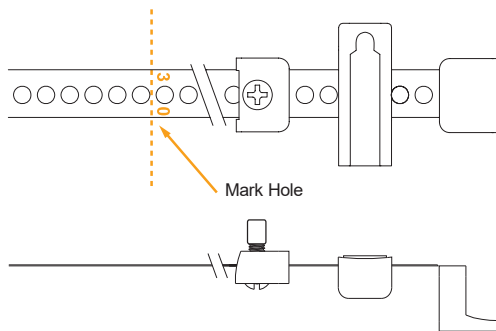

#### 2 Step 2

Cut off excessive mounting band.

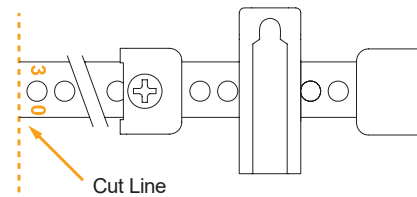

#### 3 Step 3

Insert screw through screw fixture and the appropriate hole.

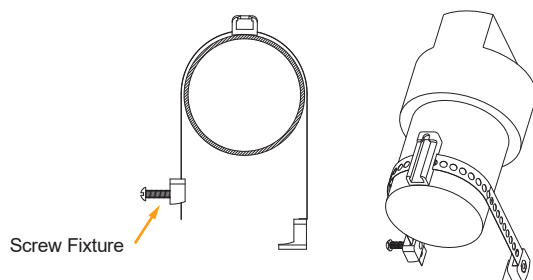

#### 4 Step 4

Wrap the mounting band around the cylinder barrel and tighten the screw 3 ~ 5 turns.

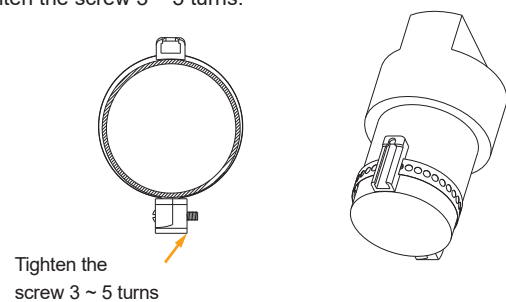

#### 5 Step 5

Mount the sensor in the BL-1 series bracket and tighten.

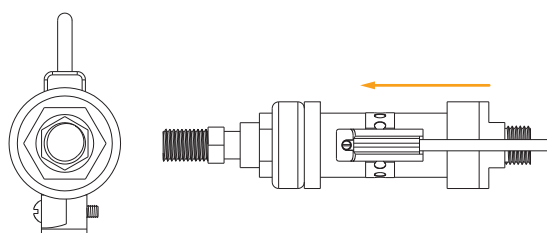

#### 6 Step 6

Adjust sensor to the sensing position and tighten.

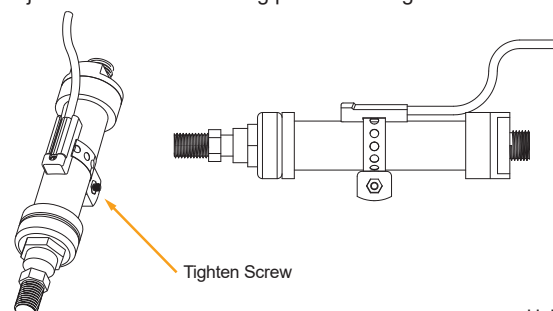

Unit : mm

## BKC-1

BKC-1 is designed for mounting KT-07 & KT-77 series sensor on round cylinder.



### How To Mount

**Example :** Use with  $\text{Ø}32$  stainless body cylinder.

Refer to the clamp marking "Stainless steel 32", and cut off the excessive portion.

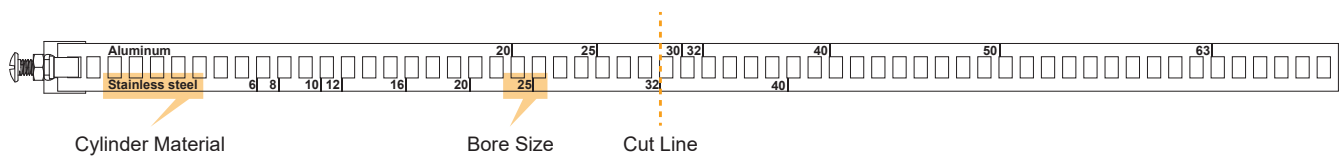

### Installation Steps

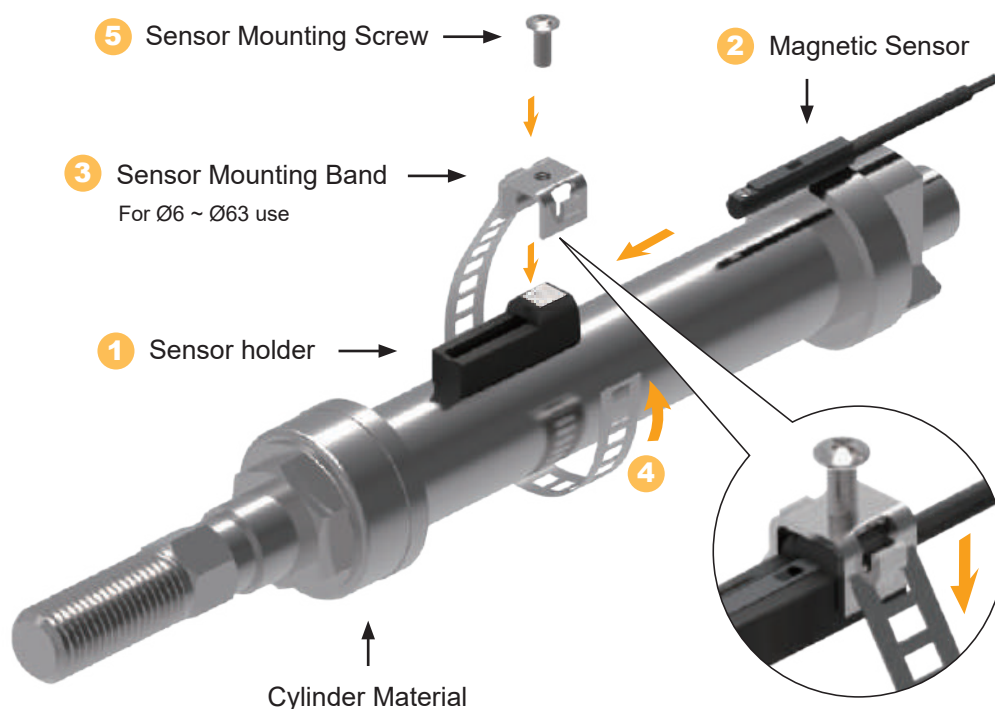

Unit : mm

# CLAMP SERIES



## BKT-1

BKT-1 is designed for mounting KT-65 & KT-75 series sensor on round cylinder.



### How To Mount

**Example :** Use with Ø32 stainless body cylinder.

Refer to the clamp marking "Stainless steel 32", and cut off the excessive portion.

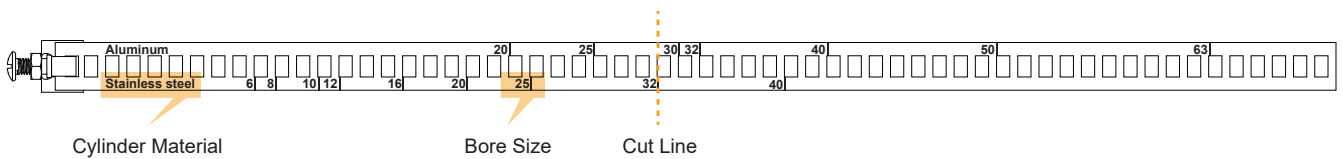

### Installation Steps

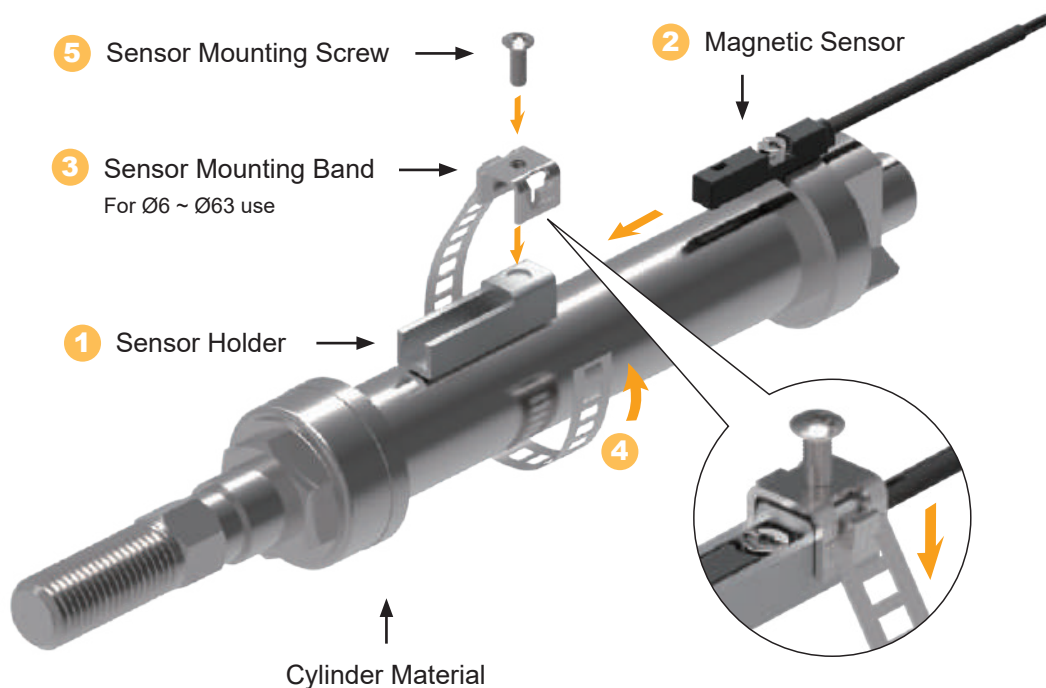

Unit : mm

## FST

FST is designed for KT-32 & KT-40 & KT-50 & KT-65 & KT-75 series sensor on Tie-Rod cylinder.

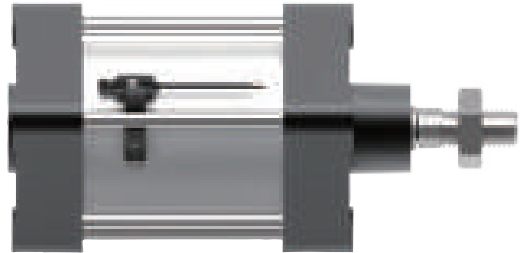

### How to mount

#### 1 Step 1

Fix sensor on bracket with 2mm hexagon wrench or flathead screwdriver.

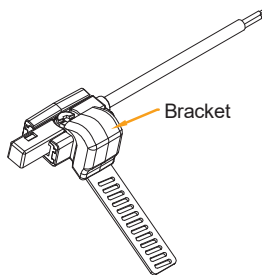

#### 2 Step 2

Insert the band between cylinder tube and Tie-Rod.

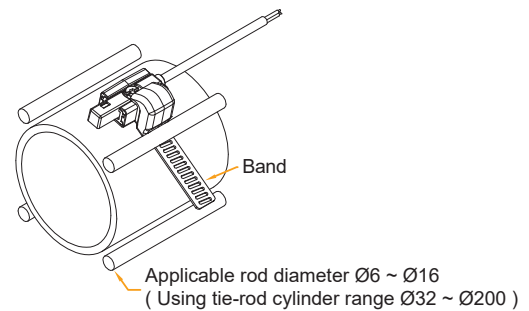

#### 3 Step 3

Slide the retaining bracket onto the band.

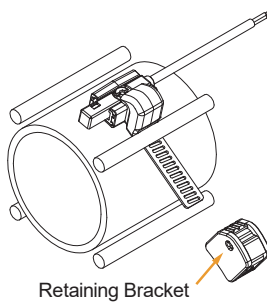

#### 4 Step 4

Adjust by moving bracket to most ideal sensing position and tighten screw. ( Torque : 5 ~ 7 kgs ).

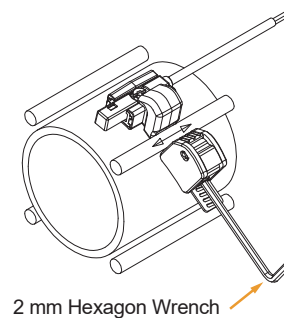

### How to dismantle

#### 1 Step 1

Use 2 mm hexagon wrench to release the screw for 2 ~ 3 turns.

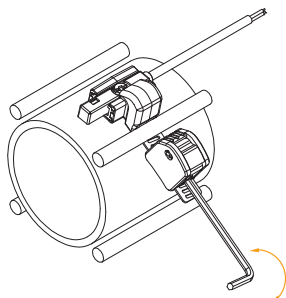

#### 2 Step 2

Use 2 mm hexagon wrench to lift up the screw cap to remove the retaining bracket.

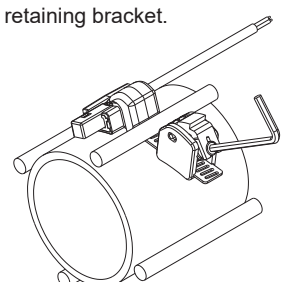

## Anisotropic Rubber Magnet

MODEL	DIM.	A / $\begin{smallmatrix} +0.00 \\ -0.80 \end{smallmatrix}$	B / $\begin{smallmatrix} +0.80 \\ -0.00 \end{smallmatrix}$	C / $\pm 0.2$
ME - 16 - 8 × 4		15.50	8.00	4.00
ME - 20 - 9 × 4		19.50	9.00	4.00
ME - 25 - 13 × 4		24.50	13.00	4.00
ME - 30 - 21 × 4		29.50	21.00	4.00
ME - 32 - 21 × 4		31.50	21.00	4.00
ME - 40 - 22 × 4		39.50	22.00	4.00
ME - 50 - 32 × 4		49.50	32.00	4.00
ME - 63 - 42 × 4		62.50	42.00	4.00
ME - 80 - 58 × 4		79.50	58.00	4.00
ME - 100 - 78 × 4		99.50	78.00	4.00
ME - 125 - 79 × 4		124.50	79.00	4.00
ME - 125 - 108 × 4		124.50	108.00	4.00
ME - 150 - 125 × 4		149.50	125.00	4.00
ME - 200 - 176 × 4		195.50	176.00	4.00

MODEL	DIM.	A / $\begin{smallmatrix} +0.00 \\ -0.80 \end{smallmatrix}$	B / $\begin{smallmatrix} +0.80 \\ -0.00 \end{smallmatrix}$	C / $\pm 0.2$
ME - 16 - 8 × 5		15.50	8.00	5.00
ME - 20 - 9 × 5		19.50	9.00	5.00
ME - 25 - 13 × 5		24.50	13.00	5.00
ME - 30 - 21 × 5		29.50	21.00	5.00
ME - 32 - 21 × 5		31.50	21.00	5.00
ME - 40 - 22 × 5		39.50	22.00	5.00
ME - 50 - 32 × 5		49.50	32.00	5.00
ME - 63 - 42 × 5		62.50	42.00	5.00
ME - 80 - 58 × 5		79.50	58.00	5.00
ME - 100 - 78 × 5		99.50	78.00	5.00

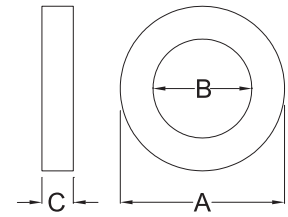

Unit : mm

## Magnetic Property

- Residual flux density ( Br ) : 2300 - 2500 gauss
- Coercive force ( iHC ) : 3000 - 3800 Oe  
( bHC ) : 2000 - 2300 Oe
- Maximum energy product : 1.3 - 1.5 Mg.Oe

## Physical Property

- Resistant power : 20 - 50 kgf / cm<sup>2</sup>
- Lengthen : 5 -20 %
- Hardness ( Shore D ) : 30 - 50
- Specific gravity : 3.5 - 3.7 g / cm<sup>3</sup>
- Temperature range : -20 °C ~ +70 °C

## Anisotropic Plastic Magnet

MODEL	DIM.	A / $\begin{smallmatrix} +0.00 \\ -0.30 \end{smallmatrix}$	B / $\begin{smallmatrix} +0.30 \\ -0.00 \end{smallmatrix}$	C / $\pm 0.2$
PME - 20 - 9 × 4		19.50	9.00	4.00
PME - 25 - 13 × 4		24.50	13.00	4.00
PME - 30 - 21 × 4		29.50	21.00	4.00
PME - 32 - 21 × 4		31.50	21.00	4.00
PME - 40 - 22 × 4		39.50	22.00	4.00
PME - 50 - 32 × 4		49.50	32.00	4.00
PME - 63 - 42 × 4		62.50	42.00	4.00
PME - 80 - 58 × 4		79.50	58.00	4.00
PME - 100 - 78 × 4		99.50	78.00	4.00

MODEL	DIM.	A / $\begin{smallmatrix} +0.00 \\ -0.30 \end{smallmatrix}$	B / $\begin{smallmatrix} +0.30 \\ -0.00 \end{smallmatrix}$	C / $\pm 0.2$
PME - 12 - 6 × 5		11.50	6.00	5.00
PME - 16 - 8 × 5		15.50	8.00	5.00
PME - 20 - 9 × 5		19.50	9.00	5.00
PME - 25 - 13 × 5		24.50	13.00	5.00
PME - 30 - 21 × 5		29.50	21.00	5.00
PME - 32 - 21 × 5		31.50	21.00	5.00
PME - 40 - 22 × 5		39.50	22.00	5.00
PME - 50 - 32 × 5		49.50	32.00	5.00
PME - 63 - 42 × 5		62.50	42.00	5.00
PME - 80 - 58 × 5		79.50	58.00	5.00
PME - 100 - 78 × 5		99.50	78.00	5.00

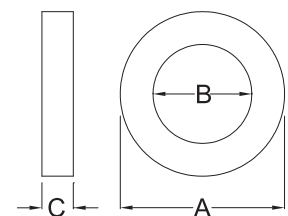

Unit : mm

## Magnetic Property

- Residual flux density ( Br ) : 2500 - 3000 gauss
- Coercive force ( iHC ) : 2700 - 3100 Oe  
( bHC ) : 2400 - 2500 Oe
- Maximum energy product : 1.8 Mg.Oe

## Physical Property

- Resistant power : 80 kgf / cm<sup>2</sup>
- Lengthen : 6.7 %
- Hardness ( Shore D ) : 120
- Specific gravity : 3.2 g / cm<sup>3</sup>
- Temperature range : -20 °C ~ +100 °C

**M8 □ R Series**



P.137

**KM8 □ R Series**



P.138

**M8 □ QD Series**



P.139

**M8 □ SW Series**



P.140

**M12 □ R Series**



P.141

**M12 □ QD Series**



P.142

## Ordering Information

**M 8 3 R - P U R - 2 M**



### Cable Length

2M : 2 Meters  
5M : 5 Meters

### Type of Connector

R : Female, Straight cable socket  
RL : Female, Angle cable socket

### Cable Material

PVC : ø4.5 PVC cable  
PUR : ø4.5 PUR cable

### Connector Series

M83 : M8 3Pin connector  
M84 : M8 4Pin connector

## Specifications

MODEL	M83R - □ M83RL - □	M84R - □ M84RL - □
Female Pinout		
Characteristics		
Conductor Colors	1 : Brown 3 : Blue 4 : Black	1 : Brown 2 : White 3 : Blue 4 : Black
Number Of Contacts	3	4
Rated Voltage	60 V AC / DC	
Rated Current	3 A	
Contact Material	Gold plated brass	
Contact Bearer Material	PA	
Housing Material	PP	
Housing Color	Black	
Cable Material	PVC	PUR
Cable Color	Gray	Black
Cable Conductor	24 AWG	
Circuit	-	
Led Color	-	
Protection Class ( IEC60529 )	IP 67	
Temperature Range	-20 ~ 80 °C	

## Dimensions

### ▪ M83R / M84R

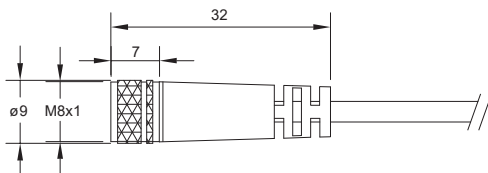

### ▪ M83RL / M84RL

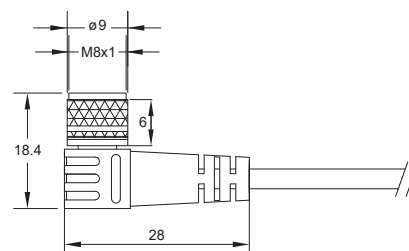

Unit : mm

## Ordering Information

**K M 8 3 R - P U R - 2 M**



### Cable Length

2M : 2 Meters  
5M : 5 Meters

### Type of Connector

R : Female, Straight cable socket  
RL : Female, Angle cable socket

### Cable material

PVC :  $\phi$ 4.5 PVC cable  
PUR :  $\phi$ 4.5 PUR cable

### Connector Series

KM83 : M8 3Pin connector  
KM84 : M8 4Pin connector

## Specifications

MODEL	KM83R - <input type="checkbox"/> KM83RL - <input type="checkbox"/>		KM84R - <input type="checkbox"/> KM84RL - <input type="checkbox"/>	
Female Pinout				
Characteristics				
Conductor Colors	1 : Brown 3 : Blue 4 : Black		1 : Brown 2 : White 3 : Blue 4 : Black	
Number Of Contacts	3		4	
Rated Voltage	60 V AC / DC			
Rated Current	3 A			
Contact Material	Gold plated brass			
Contact Bearer Material	PC + ABS			
Housing Material	TPV			
Housing Color	Black			
Cable Material	PVC	PUR	PVC	PUR
Cable Color	Gray	Black	Gray	Black
Cable Conductor	24 AWG			
Circuit	-			
Led Color	-			
Protection Class ( IEC60529 )	IP 67			
Temperature Range	-20 ~ 80 °C			

## Dimensions

### ■ KM83R / KM84R

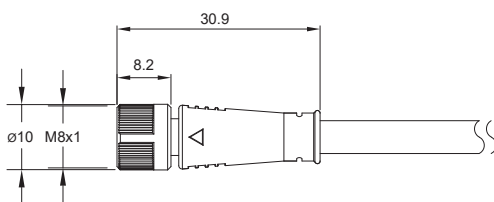

### ■ KM83RL / KM84RL

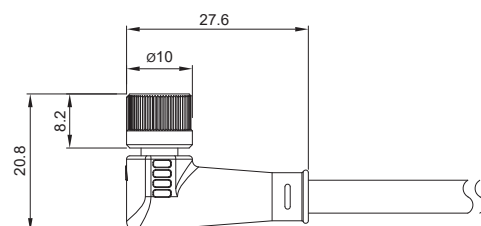

Unit : mm

## Ordering Information

**M 8 3 Q D - P U R - 2 M**



## Cable length

2M : 2 Meters  
5M : 5 Meters

## Type of Connector

QD : Male, Straight cable plug

## Cable Material

PVC : ø4.5 PVC cable  
PUR : ø4.5 PUR cable

## Connector Series

M83 : M8 3Pin connector  
M84 : M8 4Pin connector

## Specifications

MODEL	M83QD - □	M84QD - □		
Male Pinout				
Characteristics				
Conductor Colors	1 : Brown 3 : Blue 4 : Black	1 : Brown 2 : White 3 : Blue 4 : Black		
Number Of Contacts	3	4		
Rated Voltage	60 V AC / DC			
Rated Current	3 A			
Contact Material	Gold plated brass			
Contact Bearer Material	PA			
Housing Material	PP			
Housing Color	Black			
Cable Material	PVC	PUR	PVC	PUR
Cable Color	Gray	Black	Gray	Black
Cable Conductor	24 AWG			
Circuit	-			
Led Color	-			
Protection Class ( IEC60529 )	IP 67			
Temperature Range	-20 ~ 80 °C			

## Dimensions

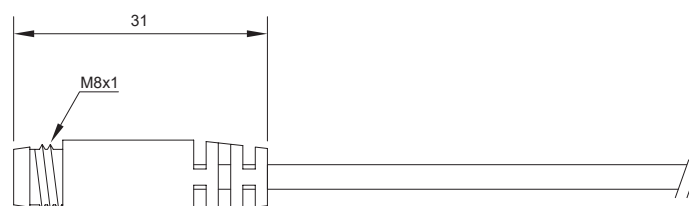

Unit : mm

## Ordering Information

**M 8 3 S W - P U R - 2 M**



### Cable Length

2M : 2 Meters  
5M : 5 Meters

### Type of Connector

SW : Male, swivel lock nut,  
Straight cable plug  
SWL : Male, swivel lock nut,  
Angle cable plug

### Cable Material

PVC :  $\varnothing$ 4.5 PVC cable  
PUR :  $\varnothing$ 4.5 PUR cable

### Connector Series

M83 : M8 3Pin connector  
M84 : M8 4Pin connector

## Specifications

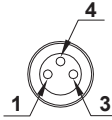
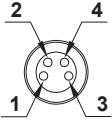
MODEL	M83SW - <input type="checkbox"/> M83SWL - <input type="checkbox"/>	M84SW - <input type="checkbox"/> M84SWL - <input type="checkbox"/>		
Male Pinout				
Characteristics				
Conductor Colors	1 : Brown 3 : Blue 4 : Black	1 : Brown 2 : White 3 : Blue 4 : Black		
Number Of Contacts	3	4		
Rated Voltage	60 V AC / DC			
Rated Current	3 A			
Contact Material	Gold plated brass			
Contact Bearer Material	PU			
Housing Material	PU			
Housing Color	Black			
Cable Material	PVC	PUR	PVC	PUR
Cable Color	Gray	Black	Gray	Black
Cable Conductor	24 AWG			
Circuit	-			
Led Color	-			
Protection Class ( IEC60529 )	IP 67			
Temperature Range	-20 ~ 80 °C			

## Dimensions

### M83SW / M84SW

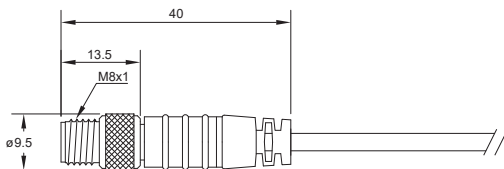

### M83SWL / M84SWL

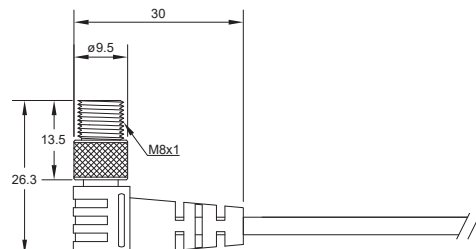

Unit : mm

# M12 □ R SERIES



## Ordering Information

**M 1 2 3 R - P U R - 2 M**



### Cable Length

2M : 2 Meters  
5M : 5 Meters

### Type of Connector

R : Female, Straight cable socket  
RL : Female, Angle cable socket

### Cable Material

PVC : ø5 PVC cable  
PUR : ø5 PUR cable

### Connector Series

M123 : M12 3Pin connector  
M124 : M12 4Pin connector  
M125 : M12 5Pin connector

## Specifications

MODEL	M123R - □ M123RL - □	M124R - □ M124RL - □	M125R - □ M125RL - □			
Female Pinout						
Characteristics						
Conductor Colors	1 : Brown 2 : N / C ( NO connect ) 3 : Blue 4 : Black 5 : N / C ( NO connect )	1 : Brown 2 : White 3 : Blue 4 : Black 5 : N / C ( NO connect )	1 : Brown 2 : White 3 : Blue 4 : Black 5 : Gray			
Number Of Contacts	3	4	5			
Rated Voltage	250 V AC / DC		60 V AC / DC			
Rated Current	4 A					
Contact Material	Gold plated brass					
Contact Bearer Material	PU					
Housing Material	PU					
Housing Color	Black					
Cable Material	PVC	PUR	PVC	PUR	PVC	PUR
Cable Color	Black					
Cable Conductor	22 AWG					
Circuit	-					
Led Color	-					
Protection Class ( IEC60529 )	IP 67					
Temperature Range	-20 ~ 80 °C					

## Dimensions

### M123R / M124R / M125R

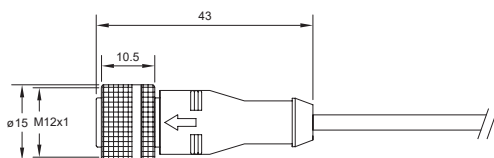

### M123RL / M124RL / M125RL

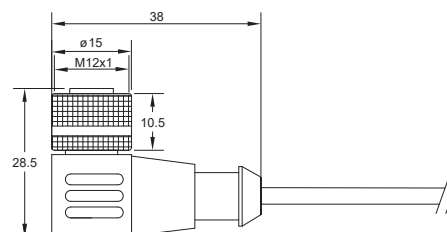

Unit : mm

# M12 □ QD SERIES



## Ordering Information

**M 1 2 3 Q D - P U R - 2 M**



### Cable Length

2M : 2 Meters  
5M : 5 Meters

### Type of Connector

QD : Male, Straight cable plug  
QDL : Male, Angle cable plug

### Cable Material

PVC : ø5 PVC cable  
PUR : ø5 PUR cable

### Connector Series

M123 : M12 3Pin connector  
M124 : M12 4Pin connector  
M125 : M12 5Pin connector

## Specifications

MODEL	M123QD - □ M123QDL - □	M124QD - □ M124QDL - □	M125QD - □ M125QDL - □			
Male Pinout						
Characteristics						
Conductor Colors	1 : Brown 3 : Blue 4 : Black	1 : Brown 2 : White 3 : Blue 4 : Black	1 : Brown 2 : White 3 : Blue 4 : Black 5 : Gray			
Number Of Contacts	3	4	5			
Rated Voltage	250 V AC / DC		60 V AC / DC			
Rated Current	4 A					
Contact Material	Gold plated brass					
Contact Bearer Material	PU					
Housing Material	PU					
Housing Color	Black					
Cable Material	PVC	PUR	PVC	PUR	PVC	PUR
Cable Color	Black					
Cable Conductor	22 AWG					
Circuit	-					
Led Color	-					
Protection Class ( IEC60529 )	IP 67					
Temperature Range	-20 ~ 80 °C					

## Dimensions

### ■ M123QD / M124QD / M125QD

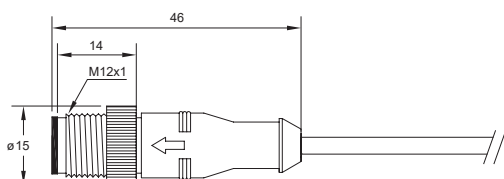

### ■ M123QDL / M124QDL / M125QDL

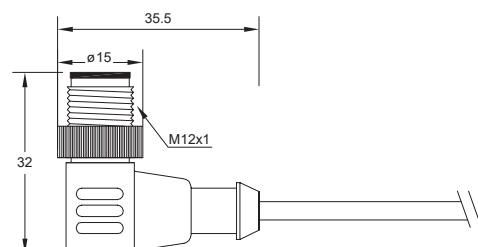

Unit : mm

## Conversion Factors

### Length

inch - mm	inch × 25.4 = mm	mm × 0.03937 = inch
inch - cm	inch × 2.54 = cm	cm × 0.3937 = inch
feet - m	feet × 0.3048 = m	m × 3.2808 = feet
yard - m	yard × 0.9144 = m	m × 1.0936 = yard

### Weight

g - ounce	g × 0.0352 = oz	ounce × 28.349 = g
kg - pound	kg × 2.2046 = lb.	lb. × 0.4535 = kg

### Pressure ( Vacuum )

Pa - kgf / cm <sup>2</sup>	Pa × 0.00001 = kgf / cm <sup>2</sup>	kgf / cm <sup>2</sup> × 98070 = Pa
kPa - kgf / cm <sup>2</sup>	kPa × 0.0102 = kgf / cm <sup>2</sup>	kgf / cm <sup>2</sup> × 980.71 = kPa
MPa - kgf / cm <sup>2</sup>	MPa × 1.02 = kgf / cm <sup>2</sup>	kgf / cm <sup>2</sup> × 0.098 = MPa
Pa - psi	Pa × 0.000145 = psi	psi × 6895 = Pa
kPa - psi	kPa × 0.145 = psi	psi × 6.895 = kPa
MPa - psi	MPa × 145 = psi	psi × 0.006895 = MPa
kPa - in. Hg	kPa × 0.2953 = in. Hg	in. Hg × 3.3864 = kPa
mmHg - in. Hg	mmHg × 0.03937 = in. Hg	in. Hg × 25.4 = mmHg
mmHg - Torr	mmHg + 760 = Torr	Torr - 760 = mmHg

### Air Flow

SCFM - NI / min	SCFM × 28.57 = NI / min	NI / min × 0.035 = SCFM
-----------------	-------------------------	-------------------------

### Effective Cross-Sectional Area - Cv Factor

mm <sup>2</sup> = Cv	mm <sup>2</sup> × 0.0542 = Cv	Cv × 18.45 = mm <sup>2</sup>
----------------------	-------------------------------	------------------------------

### Temperature

°C - °F	°C × 9 / 5 + 32 = °F	( °F - 32 ) × 5 / 9 = °C
---------	----------------------	--------------------------

### Force

N - kgf	N × 0.10197 = kgf	kgf × 9.8067 = N
N - lbf	N × 0.22481 = lbf	lbf × 4.4482 = N
kgf - lbf	kgf × 2.20462 = lbf	lbf × 0.45359 = kgf

### Torque

N. m - kgf. m	N. m × 0.10197 = kgf. m	kgf. m × 9.8067 = N. m
N. m - lbf. ft	N. m × 0.73756 = lbf. ft	lbf. ft × 1.3558 = N. m
kgf. m - lbf. ft	kgf. m × 7.233 = lbf. ft	lbf. ft × 0.13826 = kgf. m



## Asia

### Taiwan

#### **KITA SENSOR TECH. CO., LTD.**

NO.20, Wucyuan 8th Rd., Wugu Dist.,  
New Taipei City 24891, Taiwan  
TEL : +886-2-2299-3794  
FAX : +886-2-2298-8704  
E-mail : sales01@kita.com.tw  
http : //www.kita.com.tw

### China

#### **KITA ELECTRONIC (CHANG SHU) CO., LTD.**

Wang-Zhuang Industrial Park, Shanghu Zhen,  
Chang-Shu City, Jiang-Su, China  
TEL : +86-512-5243-8951~3  
FAX : +86-512-5243-8950  
E-mail : kita\_changshu@kita.com.tw  
http : //www.kitasensor.com

### Japan Office

#### **MING-SHING(JAPAN)INC.**

4-7-21 Eifuku Sugunami-Ku Tokyo  
168-0064, Japan  
TEL : +81-3-3323-8638  
FAX : +81-3-3323-8048  
E-mail : yuichinishihara-msg@nifty.com  
http : //www.star-pneumatic.com

### India Office

#### **PARMA & PARMA (INDIA) PVT. LTD.**

Office D-86, Okhla Industrial Area Phase-1,  
New Delhi 110020  
TEL : + 91-11-2681-1132/33  
E-mail : marketing@parmaindia.com,  
info@parmaindia.com  
http : //www.parmaindia.com

## Europe

### France Office

#### **DESBOIS BOTALAM INDUSTRIE ( DBI )**

95, Boulevard Aristide Briand  
93106 MONTREUIL CEDEX, France  
TEL : +33-1-4857-2024  
FAX : +33-1-4857-1975  
E-mail : dbi@dbigroupe.com  
http : //www.dbigroupe.com

### Italy Office

#### **PARSEC SAS DI FIORE L. & C.**

Via Parini, 2  
20090 Vimodrone MI, ITALY  
TEL : +39-02-2740-1693  
E-mail : commerciale.parsec@gmail.com  
http : //www.parsecitalia.com

### Scandinavian Office

#### **HEMOMATIK AB**

Lanna, Nyckelvagen 7  
S-142 50 Skogas, Stockholm, Sweden  
TEL : +46-8-771-3580  
FAX : +46-8-771-6200  
E-mail : erik@hemomatik.se  
http : //www.hemomatik.se

## America

### America Office

#### **ADSSENS TECHNOLOGY, INC.**

18310 Bedford Circle,  
City of Industry, CA 91744-5971, U.S.A.  
TEL : +1-626-854-2773  
FAX : +1-626-854-8183  
E-mail : sales@adsens.net  
http : //www.adsens.net

### Brazil Office

#### **TAIPAN TECNOLOGIA**

Rua Dos Andradas 1251 Sala 71  
Porto Alegre-RS-Brasil  
Cep : 90020-009  
TEL : +55-51-3286-5277  
FAX : +55-51-3225-0849  
E-mail : vendas@taipantecnologia.com  
http : //www.taipantecnologia.com

Learn more >>



© 2018 KITA SENSOR TECH. CO., LTD.