

KT-71 SERIES

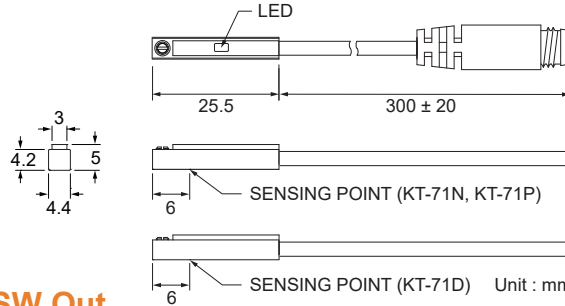

Dimensions

KT-71D, KT-71N, KT-71P /
KT-71D-QD, KT-71N-QD, KT-71P-QD



SW Out

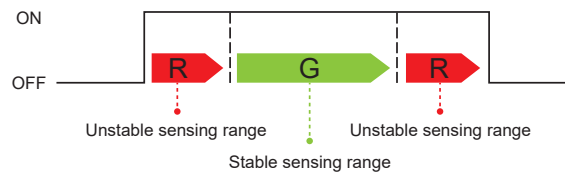

- Dual Color LED allow more precise positioning

QD Pinout

3 wire QD wiring

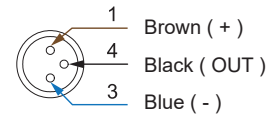

2 wire QD wiring

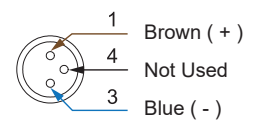

2 wire EQD wiring

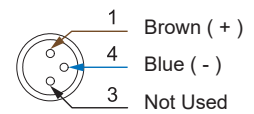

Specifications

MODEL	KT-71D	KT-71N	KT-71P
Connect Diagram			
Characteristics			
Wiring Method	2-Wire Type	3-Wire Type	
Switching Logic	Solid State Output, Normally Open		
Sensor Type	-	NPN Current Sinking	PNP Current Sourcing
Operating Voltage	10 ~ 28 V DC		
Switching Current	80 mA max.		
Contact Rating ※1	2 W max.		
Current Consumption ※2	-	10 mA @ 24 V DC max.	
Voltage Drop ※2	4 V max.	1.5 V max.	
Leakage Current ※2	1 mA max.	0.05 mA max.	
Indicator	Red LED : unstable sensing range ; Green LED : stable sensing range		
Lead Wire	Ø2.8 PUR - 26 AWG (0.15 mm ²) - 2 cores	Ø2.8 PUR - 26 AWG (0.15 mm ²) - 3 cores	
Operating Frequency	1000 Hz		
Magnet Requirement ※2, 3	85 Gauss		
Temperature Range	-10 ~ 60 °C		
Shock ※4	50 G		
Vibration ※5	9 G		
Enclosure	IEC 60529 IP67		
Protection Circuit ※6	2, 3, 4		

NOTE

- ※1 : WARNING : Never exceed rating (Watt = Voltage × Amperage). Permanent damage to sensor will occur.
- ※2 : It bases on conditions of voltage 24 V DC, ambient temp. 25 °C and 2 meters cable of sensor. Voltage drop increases in pace with cable length.
- ※3 : Measuring standard target : Ø15.5 × Ø8 × 5t (Anisotropy rubber magnet)

- ※4 : Sin wave / X, Y, Z 3 directions / 3 times each direction / 11 ms each time.
- ※5 : Double amplitude 1.5 mm / 10 Hz ~ 55 Hz ~ 10 Hz (Sweep 1 min) / X, Y, Z 3 directions / 1 hour each time.
- ※6 : 1 = None / 2 = Short-circuit / 3 = Power Source Reverse polarity / 4 = Surge Suppression

Groove Dimensions

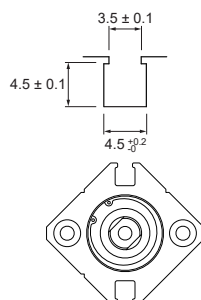

Unit : mm