

Features

- Design for large flow.
- Flow and pressure dual sensor.
- 200 : 1 ratio covers a wider flow range.
- Flow and pressure 4 digit, 7 segment dual LCD display.
- 7 segment 8 digit LCD display.
- Accumulated flow rate display at a glance.
- Real-time monitoring.

Patented

RS485 MODBUS CONTROL

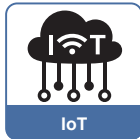
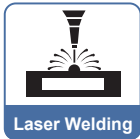
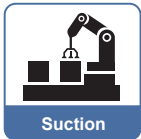

Features Highlight

1 2-in-1 Design

- Pressure and flow rate simultaneous monitoring



2 Cost Reduction

- KFP02A series significantly reduces costs comparing with conventional product

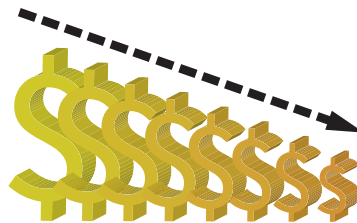

3 High Performance

- High Precision

	Pressure	Flow
Indicator accuracy	± 2 % F.S.	± 3 % F.S.
Repeatability	± 0.2 % F.S.	± 1 % F.S.

- Multiple Output Function

Digital Display	Instantaneous flow value Accumulated flow value Pressure value
Switch Output	NPN output PNP output
Analog output	Voltage output 1~5 V Current output 4~20 mA
Accumulated Pulse Output	50ms pulse output

4 Air Consumption Monitoring

- Monitor air consumption of devices



+

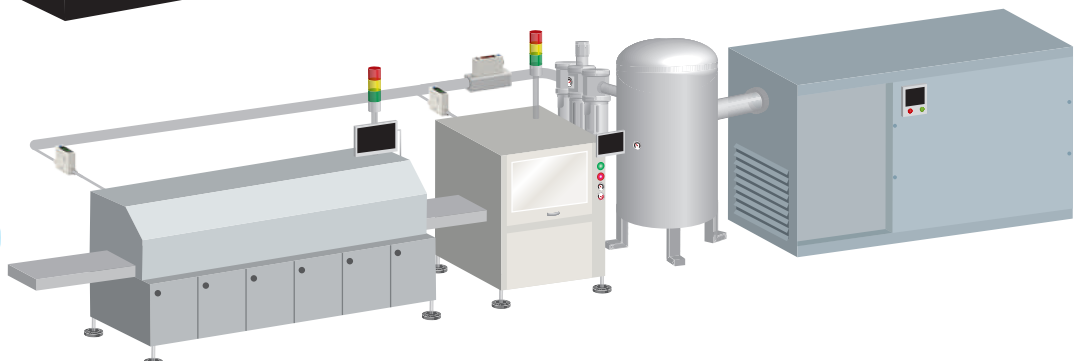
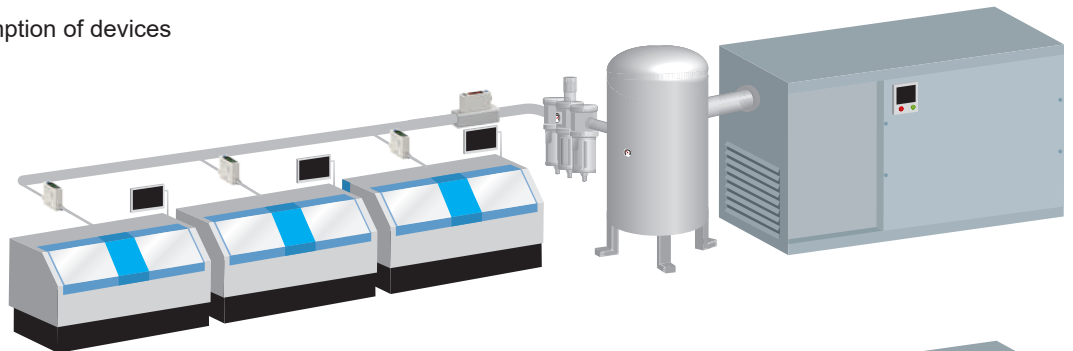



Specifications

Model		501	102	202
Fluid		Dry air, N ₂ , Non-corrosive / Non-flammable gas		
Sensor Element	Flow	Measured Flow Rate Range 2 ~ 500 L/min	5 ~ 1000 L/min	10 ~ 2000 L/min
	Pressure	Flow Direction Unidirection	Rated Pressure Range -100 ~ 1000 kPa	
Display		4 digital × 4 digital, 7 segment LCD display (Red / Green / Orange)		
Instant Flow Rate	Display Range	0 ~ 525 L/min	0 ~ 1050 L/min	0 ~ 2100 L/min
	Minimum Setting Scale	LPM 1 L/min	CFM 0.1 ft ³ /min	
Accumulated Flow	Display Range	99999999 L		
	Minimum Setting Scale	1 L 0.1 ft ³		
Pressure Display	Display Range	-100 ~ 1000 kPa		
	Minimum Setting Scale	kPa	1	
		kgf/cm ²	0.01	
		bar	0.01	
psi	0.1			
Accuracy	Flow	Guaranteed Range	2 ~ 100 % F.S.	
		Indicator Accuracy	± 3 % F.S. ± 1 digit ※1	
		Analog Output Accuracy	± 5 % F.S. ※1	
		Repeatability	± 1 % F.S. ± 1 digit (± 2 % F.S. when response time is set to 50 ms) ※2	
		Linearity	± 3 % F.S. ※2	
	Pressure	Temp. Characteristic	± 5 % F.S. ※2	
		Pressure Characteristic	± 5 % F.S. ± 1 digit ※3	
		Guaranteed Range	0 ~ 100 % F.S.	
		Indicator Accuracy	± 2 % F.S. ± 1 digit ※4	
		Analog Output Accuracy	± 2.5 % F.S. ※4	
Switch Output	Output Mode	Flow	2 NPN open collector outputs Max. Load Current : 125 mA Max. Supply Voltage : 24 V DC Voltage Drop : ≤ 1.5 V	
		Pressure	2 PNP open collector outputs Max. Load Current : 125 mA Max. Supply Voltage : 24 V DC Voltage Drop : ≤ 1.5 V	
	Hysteresis	Adjustable		
Response Time	Flow	800 ms (50 ms, 80 ms, 120 ms, 200 ms, 400 ms, 1500 ms selectable)		
	Pressure	2.5 ms (25 ms, 100 ms, 250 ms, 500 ms, 1000 ms, 1500 ms selectable)		
Output Short Circuit Protection	Yes			
Accumulated Pulse Output	Flow	5 L/Pulse	10 L/Pulse	10 L/Pulse
	Pressure	20 ft ³ /Pulse	40 ft ³ /Pulse	40 ft ³ /Pulse
Analog Output	Voltage Output	Voltage Output Range : 1 ~ 5 V ※5 Output Impedance : 1 KΩ		
	Current Output	Current Output Range : 4 ~ 20 mA ※5 Load Impedance : ≤ 300 Ω		
External Input		Non-voltage input, ≤ 0.4 V, ≥ 30 ms		
Communication Interface		RS485 ※6		
Power	Power Supply Voltage	12 ~ 24 V DC ± 10 %, Ripple (P-P) ≤ 10 % (UL class 2)		
	Current Consumption	≤ 50 mA		
Environment	Withstand Pressure	1.5 MPa		
	Enclosure	IP40		
	Working Fluid Temp.	0 ~ 50 °C (No condensation or freezing)		
	Ambient Temp. Range	Operation : 0 ~ 50 °C ; Storage : -10 ~ 60 °C (No condensation or freezing)		
	Ambient Humidity Range	Operation / Storage : 35 ~ 85 % R.H. (No condensation)		
	Withstand Voltage	250 V AC in 1-min (between case and lead wire)		
	Insulation Resistance	≥ 2 MΩ (50 V DC, between case and lead wire)		
	Vibration	Total amplitude 1.5 mm or 10 G, 10 Hz ~ 55 Hz ~ 10 Hz scan for 1 minute, 2 hours each direction of X, Y and Z		
Shock	100 m/s ² (10 G), 3 times each in direction of X, Y and Z			
Lead Wire		Ø4 Oil-resistance cable (PVC) - 26 AWG (0.15 mm ²) - 6 cores		
Weight (without 2 meter lead wire)		Approx. 281.7 g (500 / 1000 L) ; Approx. 344 g (2000 L)		

NOTE

※1 : CONDITION : Inlet Pressure : 600 kPa, Outlet Pressure : 1 atmospheric pressure, 25 °C

※2 : CONDITION : Outlet Pressure : 1 atmospheric pressure, 25 °C

※3 : 0 ~ 1.0 MPa, Outlet Pressure : 1 atmospheric pressure, 25 °C

※4 : Outlet flow rate = 0 L/min, 25 °C

※5 : Corresponding to pressure sensor 0 ~ 1000 kPa

※6 : This function only available for Output Specification -02 and -04.

Panel Description

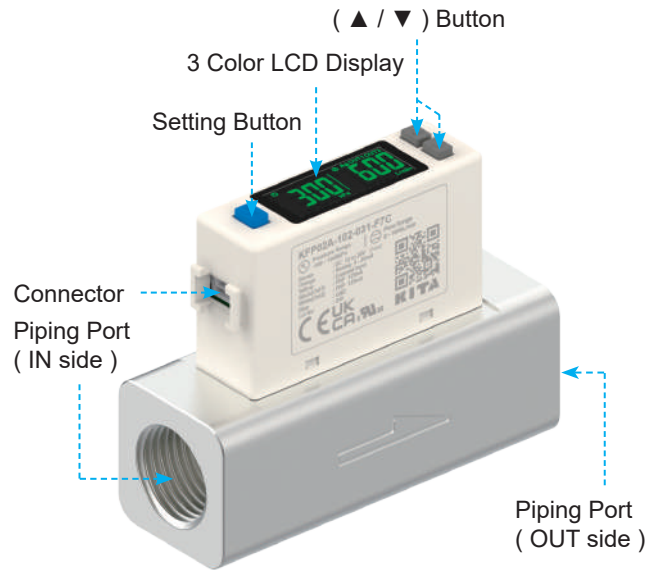
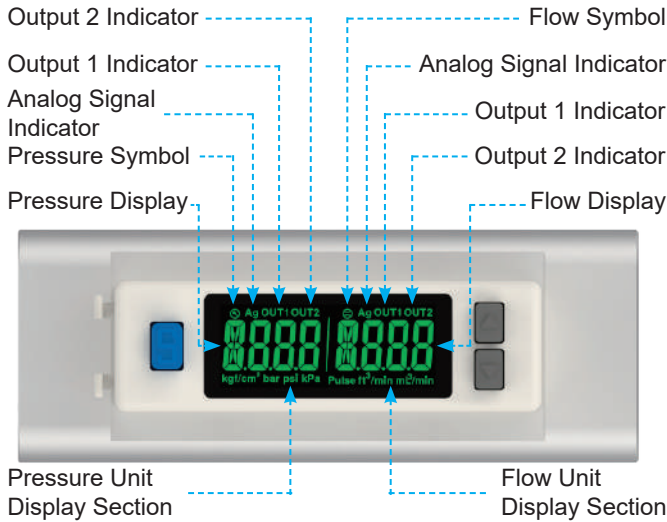

Output Circuit Wiring Diagrams

NPN Output / Analog Voltage Output / External Input

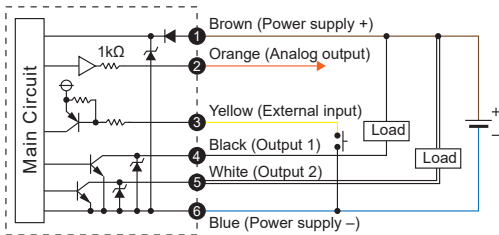

PNP Output / Analog Voltage Output / External Input

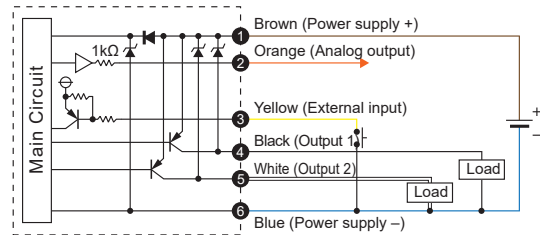

NPN Output / Analog Current Output / External Input

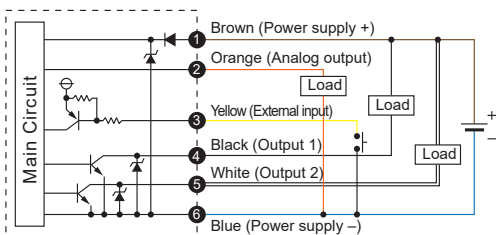

PNP Output / Analog Current Output / External Input

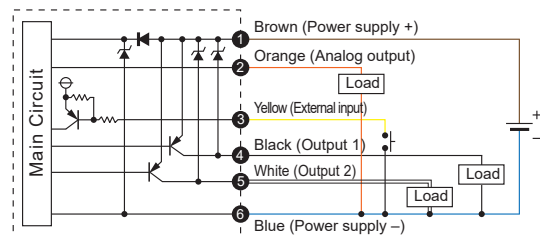

NPN Output / RS485 MODBUS Mode

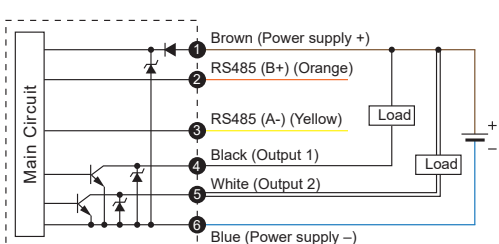

PNP Output / RS485 MODBUS Mode

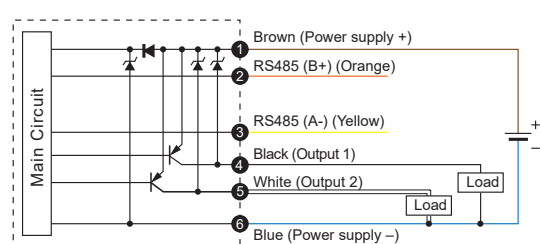

※ Wiring for RS485 MODBUS : Please connect RS485 (B+) or (A-) before connecting power supply to avoid short circuit to damage to product.

Ordering Information

K F P 0 2 A - 5 0 1 - 0 1 0 - F 7 C

Flow Rate Range

501 : 500 L/min
 102 : 1000 L/min
 202 : 2000 L/min

Output Specifications

010 : 2 NPN output + Analog output (1 ~ 5 V)
 011 : 2 NPN output + Analog output (4 ~ 20 mA)
 02 : 2 NPN output + RS485
 030 : 2 PNP output + Analog output (1 ~ 5 V)
 031 : 2 PNP output + Analog output (4 ~ 20 mA)
 04 : 2 PNP output + RS485

Port Size

F7C : Rc1/2", for Flow Rate Range 501/102.
 F9C : G1/2", for Flow Rate Range 501/102.
 F10C : Rc3/4", for Flow Rate Range 202.
 F12C : G3/4", for Flow Rate Range 202.

Optional Parts

BT-27 : Mounting bracket, for Flow Rate Range 501/102.
 BT-28 : Mounting bracket, for Flow Rate Range 202.

Dimensions

Flow Rate Range 501, 102 (Port Size : Rc1/2", G1/2")

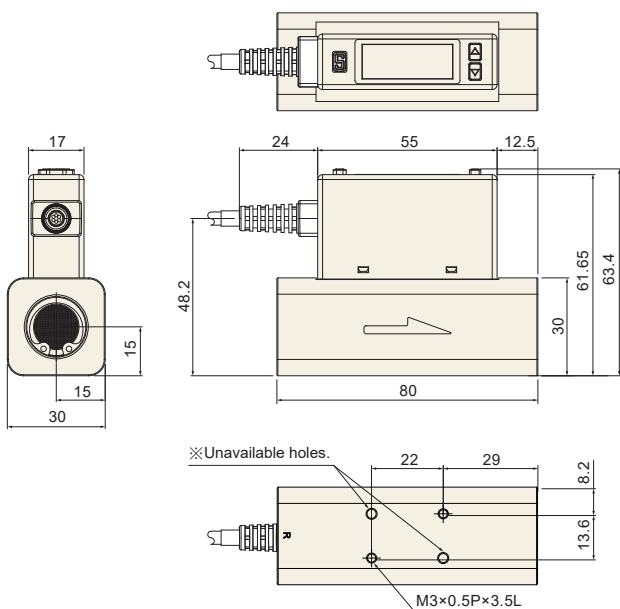

Flow Rate Range 202 (Port Size : Rc3/4", G3/4")

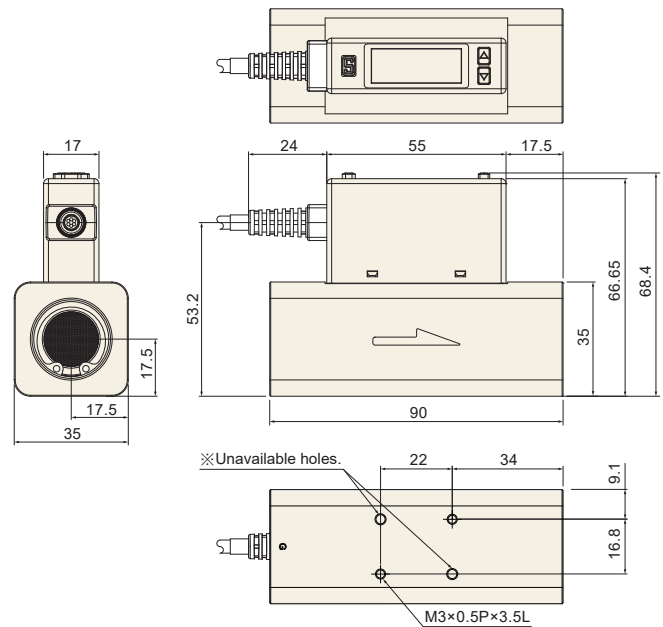

Optional Parts Dimensions

Mounting Bracket : BT-27 (Flow Rate Range 501, 102)

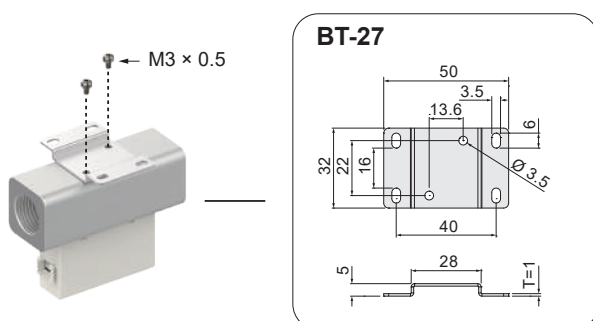

Mounting Bracket : BT-28 (Flow Rate Range 202)

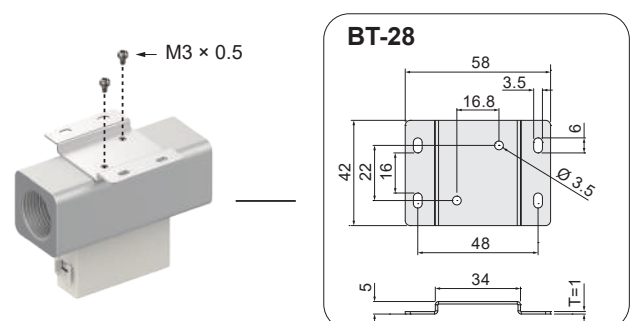

Unit : mm