

KT-89 SERIES

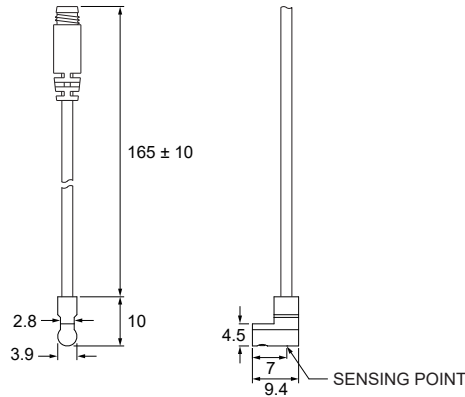

Dimensions

KT-89D, KT-89N, KT-89P /
KT-89D-QD, KT-89N-QD, KT-89P-QD



Unit : mm

M8 QD Pinout

3 wire QD wiring

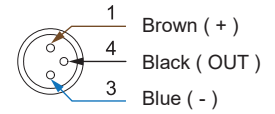

2 wire QD wiring

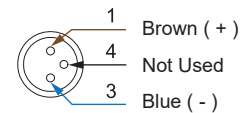

2 wire EQD wiring

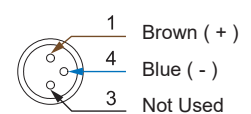

Specifications

MODEL	KT-89D	KT-89N	KT-89P
Connect Diagram			
Characteristics			
Wiring Method	2-Wire type	3-Wire type	
Switching Logic	Solid State Output, Normally Open		
Sensor Type	-	NPN Current Sinking	PNP Current Sourcing
Operating Voltage	5 ~ 30 V DC		
Switching Current	≤ 80 mA	≤ 150 mA	
Contact Rating ※1	≤ 2.4 W	≤ 4.5 W	
Current Consumption ※2	-	≤ 2 mA	
Voltage Drop ※2	≤ 4.0 V @ 80 mA	≤ 1.5 V @ 150 mA	
Leakage Current ※2	≤ 0.1 mA	≤ 0.01 mA	
Indicator	Red LED		
Lead Wire	Ø2.6 PVC - 27 AWG (0.11 mm ²) - 2 cores	Ø2.6 PVC - 27 AWG (0.11 mm ²) - 3 cores	
Operating Frequency	≤ 1000 Hz		
Magnet Requirement ※2, 3	40 ~ 1000 Gauss		
Temperature Range	-10 ~ 70 °C		
Shock ※4	50 G		
Vibration ※5	9 G		
Enclosure	IEC 60529 IP67		
Protection Circuit ※6, 7	3, 4, 5	2, 3, 4	2, 3, 4

NOTE

- ※1 : WARNING : Never exceed rating (Watt = Voltage × Amperage). Permanent damage to sensor will occur.
- ※2 : It bases on conditions of voltage 24 V DC, ambient temp. 25 °C and 2 meters cable of sensor. Voltage drop increases in pace with cable length.
- ※3 : Measuring standard target : Ø15.5 × Ø8 × 5t (Anisotropy rubber magnet)
- ※4 : Sin wave / X, Y, Z 3 directions / 3 times each direction / 11 ms each time.

- ※5 : Double amplitude 1.5 mm / 10 Hz ~ 55 Hz ~ 10 Hz (Sweep 1 min) / X, Y, Z 3 directions / 1 hour each time.
- ※6 : 1 = None / 2 = Short-circuit / 3 = Power Source Reverse polarity / 4 = Surge Suppression / 5 = Sensor thermal protection.
- ※7 : The LED will flash when Short-circuit or Sensor Thermal Protection is ON.

Groove Dimensions

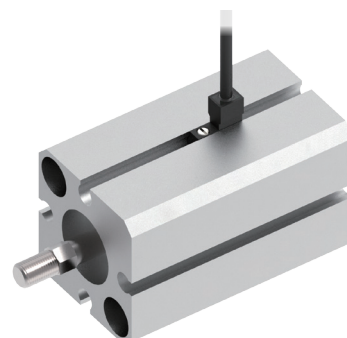
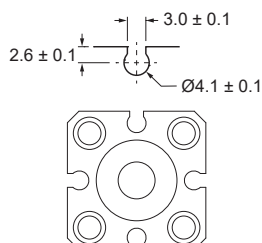

Unit : mm