

INSTRUCTION MANUAL

DIGITAL FLOW SENSOR



KF02A Series





Product Safety Instructions

■ This section indicate the levels of risks with the labels of Danger, Warning and Caution.

<p> Danger Danger indicates high level of risk, will lead to fatal or serious injuries if not avoided.</p>
<p> Warning / Avertissement Warning indicates medium level of risk, it might cause death or serious injuries.</p>
<p> Caution / Attention Caution indicates low level of risk, it might result in minor injuries, such as scald, electric shock, etc. and the product, equipment and machines might be damaged.</p>

Warning / Avertissement

■ Precautions for use

- ① **Operate within the specified voltage.**
 Malfunction or damaged product, electric shock or fire may be resulted by exceeding the specified voltage range.
 - ② **Do not exceed the maximum load current.**
 It may damage the product.
 - ③ **Do not use any load that generates surges.**
 Surge protection is present but applying surge voltage repeatedly will ultimately damage the product.
 When using with inductive load (such as relay or solenoid), please install a flyback diode across the load (polarity must be observed).
 - ④ **Observed the internal voltage drop.**
 When used at a specified voltage, if the sensor is functional but the load does not work, please check if the operating voltage of the load meets the following formula.
- $$\text{Power supply voltage} - \text{Internal voltage drop of sensor} > \text{Minimum operating voltage of load}$$
- ⑤ **Please follow the rated range of flow and pressure to avoid damage.**
 - ⑥ **Do not use flammable fluids and/or permeable fluids.**
 They may cause fire, explosion or corrosion.

■ Working fluid and working environment

- ① **Do not use in an explosive gas atmosphere.**
 The sensor does not have explosion-proof structure, fire, explosion or corrosion can result.
- ② **Do not use near a surge voltage generated area.**
 If product is nearby the device of surge voltage (e.g., lightning strikes, solenoid lifters, high frequency induction furnaces, motors, etc.), please take measures against the surge sources to prevent damage.
- ③ **Do not use in an environment where sensors could be splashed by water or oil.**
 Enclosure rating is IP40, please avoid water or oil splashed environment to prevent adversely effects.
- ④ **Do not use in an environment subject to large temperature cycling.**
 Internal components of the sensor will be damaged by large heating/cooling cycles other than ordinary changes in temperature.
- ⑤ **Do not mount the product in locations where it is exposed to radiant heat.**

Warning / Avertissement

■ Wiring Precautions

- ① **Check wire color and terminal number when wiring.**
Incorrect wiring can cause permanent damages to the sensor, check wire color and terminal number according to the manual before wiring.
- ② **Avoid repeatedly bending or stretching the lead wire.**
It can cause damage to the sheath, or breakage of the wire.
- ③ **Ensure wiring insulation**
Please ensure the insulation of the wiring (including interference from other circuits and poor insulation between terminals) to prevent overcurrent from damaging the product.
- ④ **Please use a separate route for the product wiring and any power or high voltage wiring to avoid noise interruption.**
- ⑤ **Do not short-circuit the load.**
When the load is short-circuited, an error will be displayed. But excess current may cause damage to the sensor.
- ⑥ **Do not install the product when power is on. Contacting or plugging terminals when supplying power may cause electric shock, malfunction, or damage.**
- ⑦ **RS485 products must be connected the communication wire first.**
Wiring for RS485 MODBUS, please connect RS485 (B+) or (A-) before connecting power supply to avoid short circuit to damage to product.

■ Installation Precautions

- ① **Ensure the flow direction of the fluid.**
Please follow flow direction indicator for installation and piping.
- ② **Flush out all dirt and dust by air blow before connecting the piping to the sensor.**
- ③ **Do not drop or hit.**
When installation, do not drop, hit or apply excessive shock (100m/s²), permanent damage to the internal component of the sensor may occur.
- ④ **Do not install multiple products in close proximity.**
The heat generated from each product could cause the temperature to rise and change the characteristics of product or deterioration of the plastic parts. Please set the products 10mm apart from each other.
- ⑤ **Hold the sensor body when installing.**
The tensile strength of the cable is 24.5 N and apply excessive pulling force can cause damage to the sensor.

■ Other Precautions

- ① **After power is supplied, the output will remain off until the display is turned on. Please operate the sensor after the value is shown.**
- ② **Stop the control systems before perform setting changes.**
During the initial flow and pressure setting, the product will switch the output according to the existing settings until the changes are complete.

Caution / Attention

■ Installation Precautions

- ① **Please follow the specified tightening torque.**
- ② **Do not mount the sensor in a place that will be used as a foothold.**
The product may damage if sit or step on it accidentally.
- ③ **While installing the KF02A to the pipe, please apply I.D. 9 mm or more air tube.**

■ Maintenance Precautions

- ① **Do not touch terminals or connectors when power is on.**

■ Disposal

- ① **Sensors at end-of-life must be disposed of in accordance with E-Waste regulations of the country/region, NOT disposed of with regular garbage.**

⚠ Warning / Avertissement

■ Fluid

- ① Check the regulator and flow adjustment valve before introducing the fluid.
- ② On the inlet side, be sure to install an air filter below the filtration level of 10um.

The sensing element cannot measure properly if foreign matter adheres to it.

③ Recommended Equipments and Installation

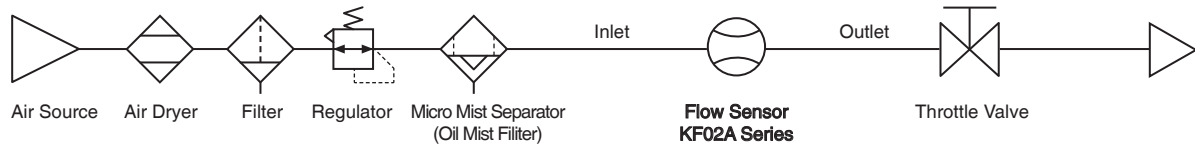

※ **NOTE** ※

Please install a throttle valve on the outlet side of the sensor to prevent errors caused by unstable flow.

Disclaimer

- ① Our warranty applies solely to our product, not to any other damages and injuries which occur by earthquakes, fires, the acts by third party, other matters, acts intentionally, acts accidentally, misuse, or other abnormal conditions that are not the responsibility of KITA.
- ② Our warranty applies solely to our product, not to any other additional damages (the loses of business profits, business interruption, etc.) incurred due to using or misusing the product.
- ③ Our warranty excludes any injuries and damages that happened by using the product beyond the specified range of function stated in the catalog or the instruction manual.

1	Installation Instructions	5
1.1	Piping	5
1.2	Mounting bracket	6
1.3	Wiring	7
1.3.1	NPN output, Analog output and external input	7
1.3.2	PNP output, Analog output and external input	8
1.3.3	NPN output, RS-485 Modbus	9
1.3.4	PNP output, RS-485 Modbus	9
2	How to Use	10
2.1	Names and Functions of Individual Parts	10
2.2	Functions Instructions	11
2.3	Operation Setting	13
3	Modbus RTU Instruction	43
4	Error Code Instruction	45
5	Specifications	46
6	Pressure Loss Characteristics	47
7	Thermal Mass Principles of Flow Sensor	47
8	Ordering Information	48
9	Dimensions	49
10	Internal Structure	51

1 Installation

1.1 Piping

Install the pipe by following the arrow indication that shows the air flow direction on the product.

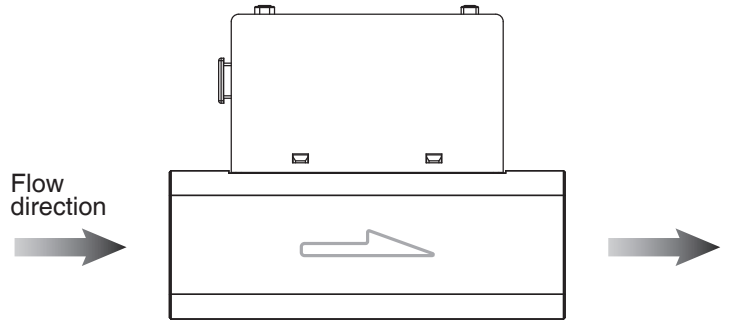

Use straight piping 8cm or longer (I.D. 9 mm or more) to connect the Piping Port (Inlet side). If straight piping is not installed, the accuracy may vary by $\pm 2\%$ F.S..

Avoid sudden changes in the piping size on the inlet side of the product.

Do not release the outlet side piping port of the product directly to the atmosphere without the piping connected.

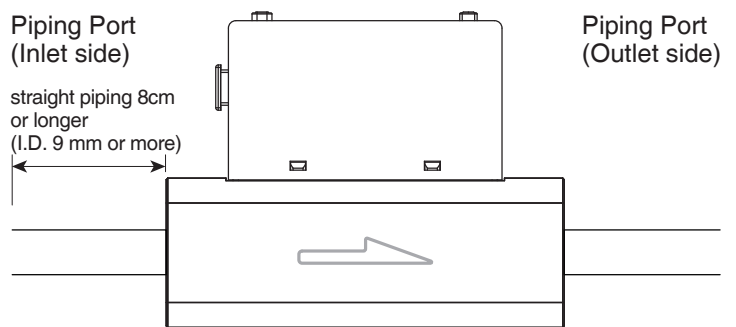

⊗ Straight Piping: The pipe is without bending and the cross sectional areas of the pipe keeps the same.

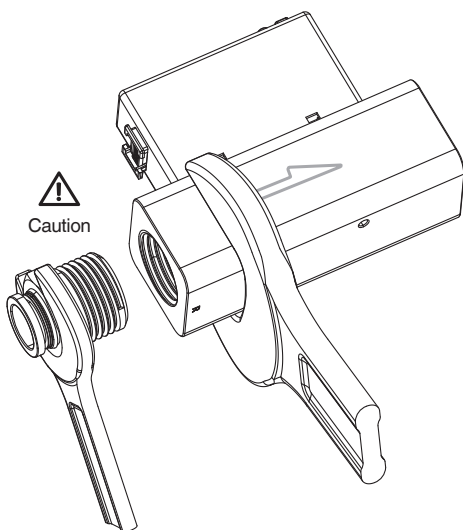

Using on other parts of the product with a wrench may damage the product.

When piping with metallic area, please refer to the applicable torque below.

Over torquing may be damaged the product.

When insufficient torque, the connection may loosen to cause air leakage.

After installation completed, please make gas and power on and operate properly and test leakage to verify the installation correct.

Piping Specification	Required Torque
Rc1/2", G1/2"	28 ~ 30 N.m
Rc3/4", G3/4"	

1.2 Mounting Bracket / Optional Parts

The LCD display may be difficult to see at certain angles.

The sensor can be installed horizontally or vertically, but the flow rates may change because of the installation way of the product or piping.

The tightening torque for screws should be under 0.3 ± 0.1 N.m.

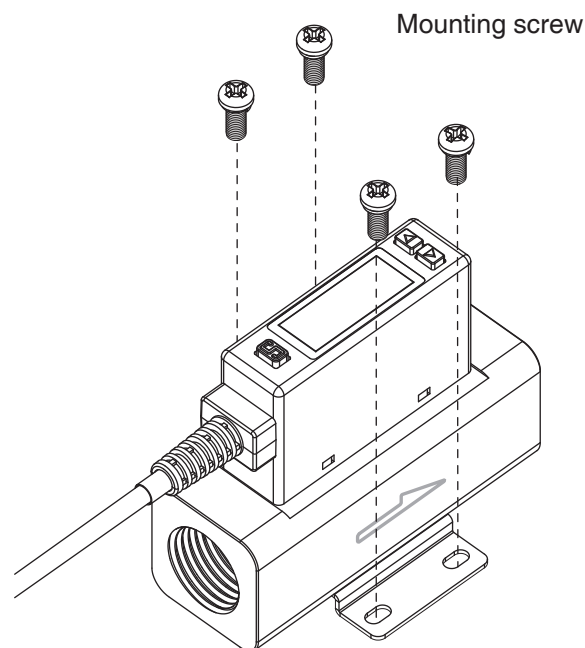
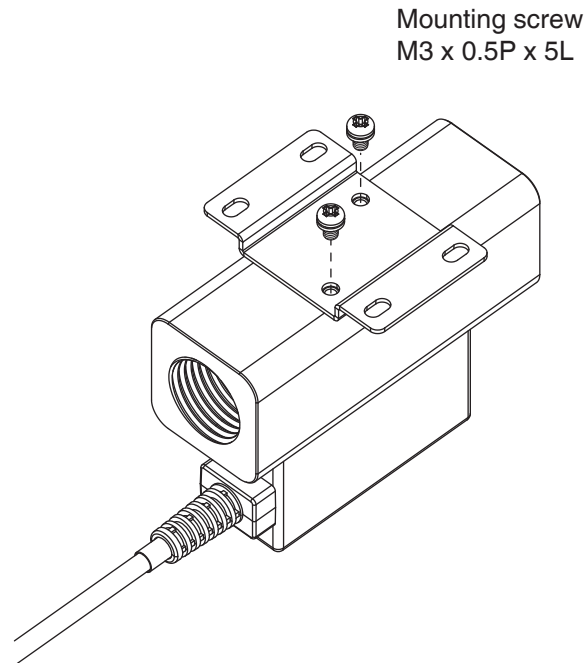

1.3 Wiring Diagrams

1.3.1 NPN Output, Analog Output and External Input

- NPN Output / Analog Voltage Output / External Input

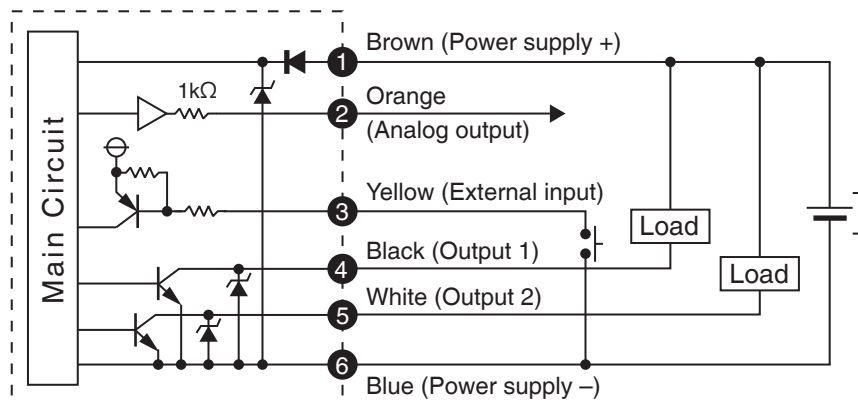

- NPN Output / Analog Current Output / External Input

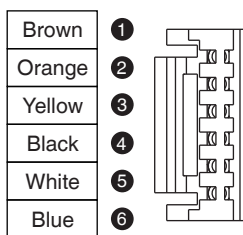
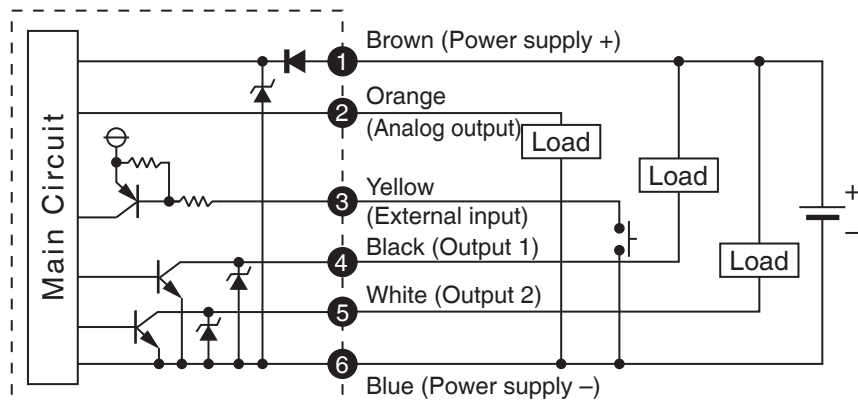

Pin No.	Line color	Content
1	Brown	Power supply (DC 12 to 24V DC)
2	Orange	Analog voltage output : 1 ~ 5V Analog current output : 4 ~ 20mA
3	Yellow	External input
4	Black	Output 1 (Max. load current : 125mA)
5	White	Output 2 (Max. load current : 125mA)
6	Blue	0V (GND)

1.3.2 PNP Output, Analog Output and External Input

● PNP Output / Analog Voltage Output / External Input

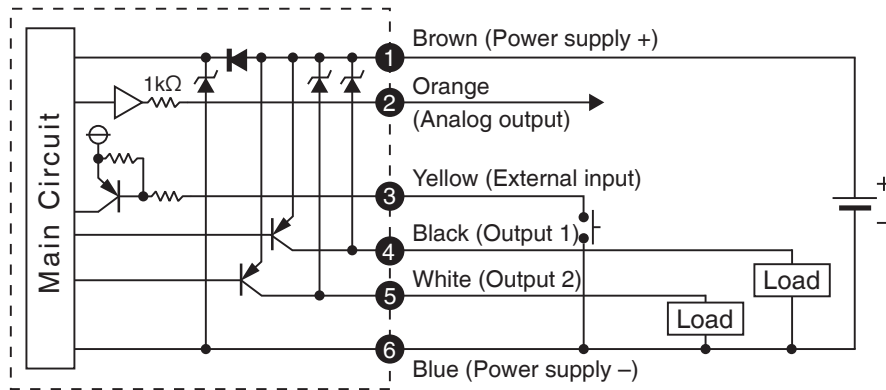

● PNP Output / Analog Current Output / External Input

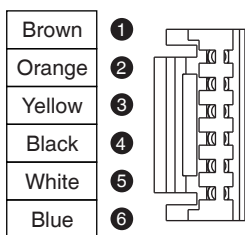
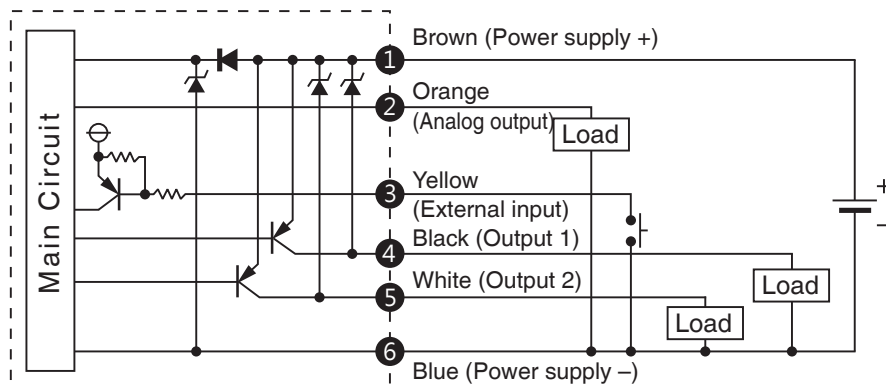

Pin No.	Line color	Content
1	Brown	Power supply (DC 12 to 24V DC)
2	Orange	Analog voltage output : 1 ~ 5V Analog current output : 4 ~ 20mA
3	Yellow	External input
4	Black	Output 1 (Max. load current : 125mA)
5	White	Output 2 (Max. load current : 125mA)
6	Blue	0V (GND)

1.3.3 NPN Output, RS-485 Modbus

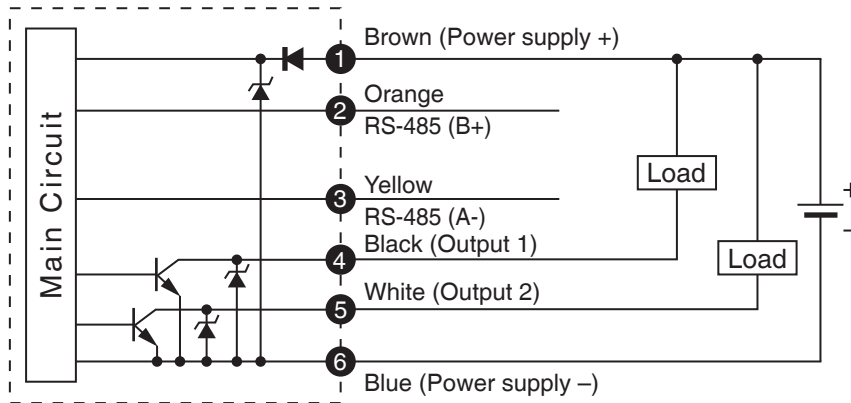

1.3.4 PNP Output, RS-485 Modbus

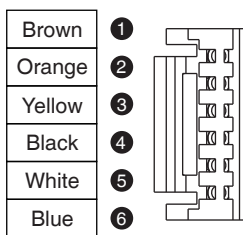
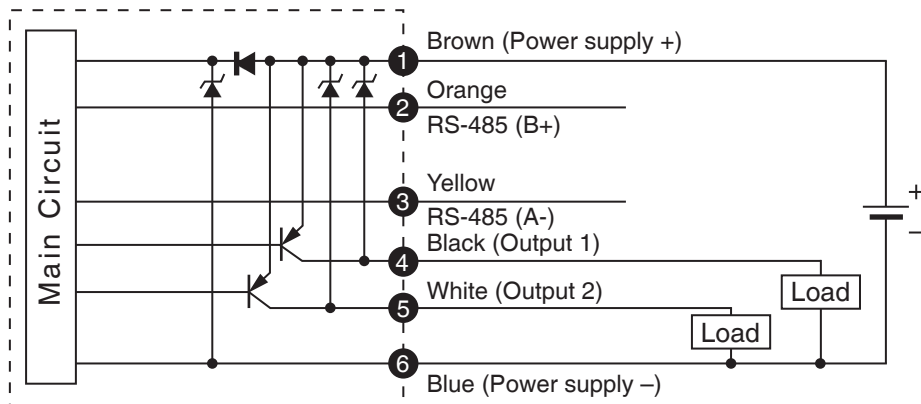

Pin No.	Line color	Content
1	Brown	Power supply (DC 12 to 24V DC)
2	Orange	RS-485 (B+)
3	Yellow	RS-485 (A-)
4	Black	Output 1 (Max. load current : 125mA)
5	White	Output 2 (Max. load current : 125mA)
6	Blue	0V (GND)

2 How to Use

2.1 Names and Functions of Individual Parts

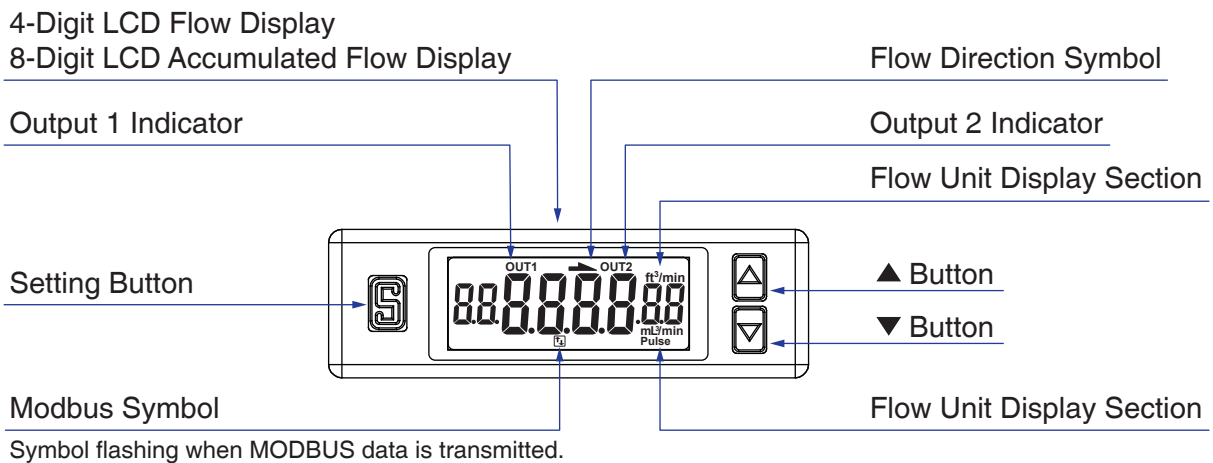
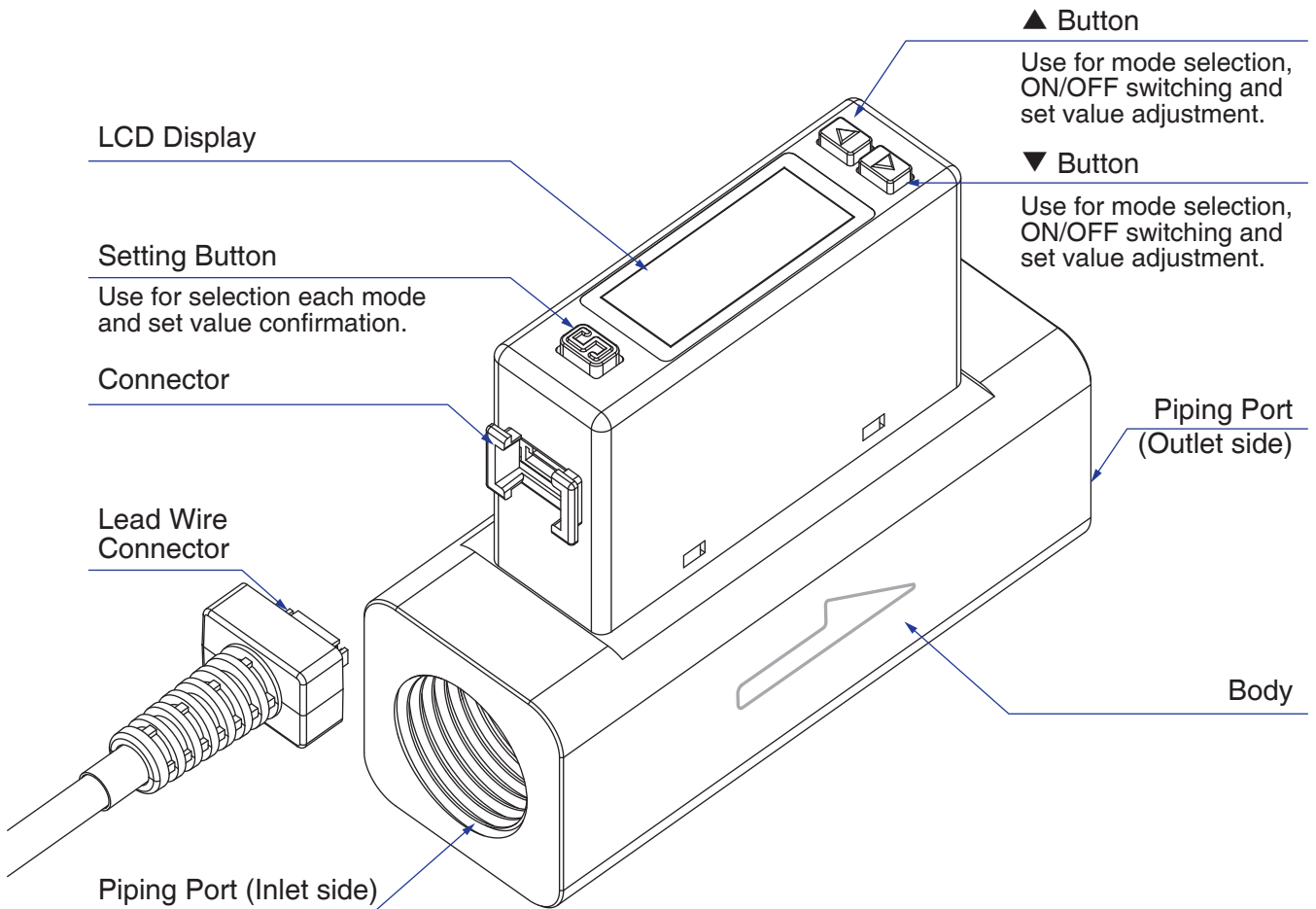

2.2 Function Instruction

● Function Setting Mode

Function Code	Item	Default setting	Explanation	Page
[F-01]	[OUT1] OUT1 setting		Set Output 1 flow value to switch ON/OFF.	P.14
	[FLOUT] OUT1 output mode	HYS		
	[OUT1] OUT1 output type	no		
	[FL-1] OUT1 set value input	50% of maximum measured flow rate 501 : 250 L/min 102 : 500 L/min 202 : 1000 L/min		
	[FH-1] OUT1 set value input	60% of maximum measured flow rate 501 : 300 L/min 102 : 600 L/min 202 : 1200 L/min		
[F-02]	[OUT2] OUT2 setting		Set Output 2 flow value to switch ON/OFF.	P.16
	[FLOUT] OUT2 output mode	HYS		
	[OUT2] OUT2 output type	no		
	[FL-2] OUT2 set value input	50% of maximum measured flow rate 501 : 250 L/min 102 : 500 L/min 202 : 1000 L/min		
	[FH-2] OUT2 set value input	60% of maximum measured flow rate 501 : 300 L/min 102 : 600 L/min 202 : 1200 L/min		
[F-03]	[LCD] LCD Display setting		Select back light color and display mode.	P.19
	[d,SP] LCD Display corresponding to output	OUT1		
	[[COL] LCD Display color setting	SOB		
[F-04]	[RESP] Response time setting	800 _(ms)	Select the response time in 50ms, 80ms, 120ms, 200ms, 400ms or 1500ms for analog output.	P.21
[F-05]	[UPdR] Display refresh time of flow sensor setting	500 _(ms)	Display refresh cycle can be set in 200ms, 500ms or 1000ms.	P.22
[F-06]	[UNIT] Unit setting		Select the UNIT of flow sensor.	P.23
	[FLOUT] Flow unit setting	LPH		
[F-07]	[REFE] Flow reference standard setting	ANR	Select the flow value is shown under standard (ANR) or normal condition (NOR).	P.24
[F-08]	[ROT] Output setting	OFF	Set Display Rotation.	P.25

Function Code	Item	Default setting	Explanation	Page
[F-09]	[EEP] Accumulated value hold setting	OFF	To save the last accumulated flow value every 2 or 5 minutes.	P.26
[F-10]	[d15] Flow sensor display mode setting		Select to display Instantaneous Flow or Accumulated Flow Mode.	P.27
	[d5P] Flow sensor display mode setting	15		
[F-80]	[5Yn] Sync the value of flow analog output and display	OFF	Turn ON to synchronize the value of flow analog output and display.	P.28
[F-90]	[Rout] Analog output range setting	OFF	Adjust the desired flow range corresponding to analog output.	P.29
	[RG_L] Min. value of desired flow range	0		
	[RG_H] Max. value of desired flow range	Max. measured flow rate		
[F-91]	[Eco] Power-Save mode setting	no	Select if turn on power-save mode to reduce power consumption	P.31
[F-92]	[inp] External input setting	r_r	Select for Accumulated flow rate zero clear, Auto-Shift or Auto-Shift zero.	P.32
[F-93]	[nb15] Modbus RTU setting		Set ID number, baud rate and transmission format.	P.33
	[id] ID number setting	1		
	[rRt] Baud rate setting	96(9600 Bd)		
	[For] Transmission format setting	8 1		
	[tR] Communications protocol setting	r11		
[F-94]	[FinE] Fine adjustment setting	OFF	The displayed value can be adjusted slightly.	P.35
[F-95]	[Fout] Forced output function		To force output ON/OFF to test the switch function.	P.36
	[out1] Forced output function	OFF		
	[out2] Forced output function	OFF		
[F-99]	[rESt] Reset to the default setting		Return to the factory default setting.	P.37
	[rSt] Reset to the default setting	OFF		

● Measurement Mode

Item	Explanation
Flow display	Display instantaneous flow rate.
Accumulated flow rate display	Display accumulated flow rate.
Instantaneous Flow rate zero setting	The displayed instantaneous flow rate value can be adjusted to "0".
Accumulated flow rate zero clear	The accumulated flow rate can be set to "0".
Peak value display	The maximum pressure or instantaneous flow can be detected when the power is supplied for a period.
Bottom value display	The minimum pressure or instantaneous flow can be detected when the power is supplied for a period.
Key lock mode	To prevent errors occurring due to unintentional changes of the set values.

2.3 Operation Instructions

Function Selection Mode

At Measurement Mode, press  button for more than 3 sec. to display [F-01]. Press  or  button to select other setting functions.

Press  for 3 sec. at Function Setting Mode to return to Measurement Mode.

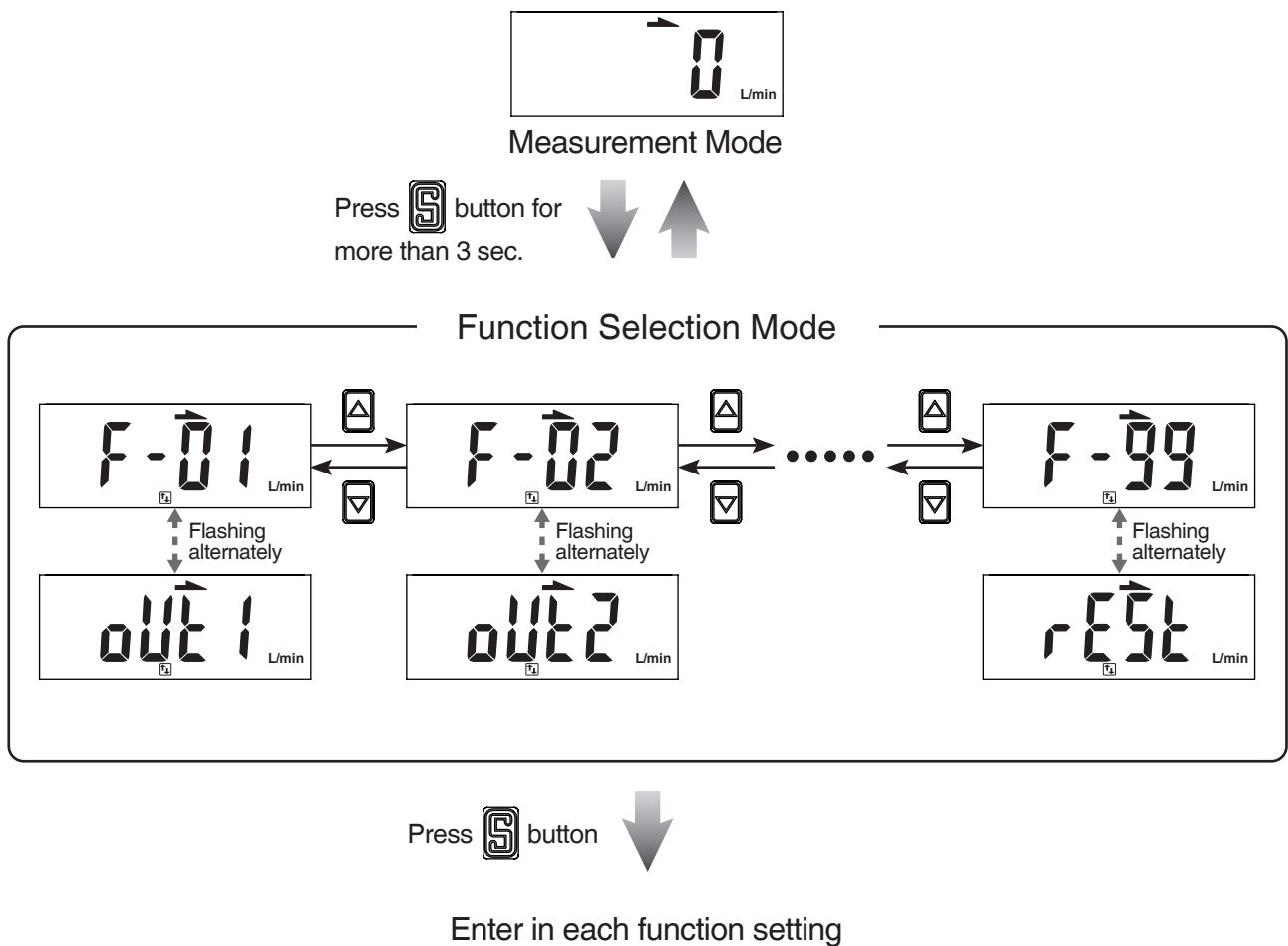

2.3.1 [F-□] OUT1 Setting

Press or button at Function Selection Mode to display [F-□] [OUT □].

Press button

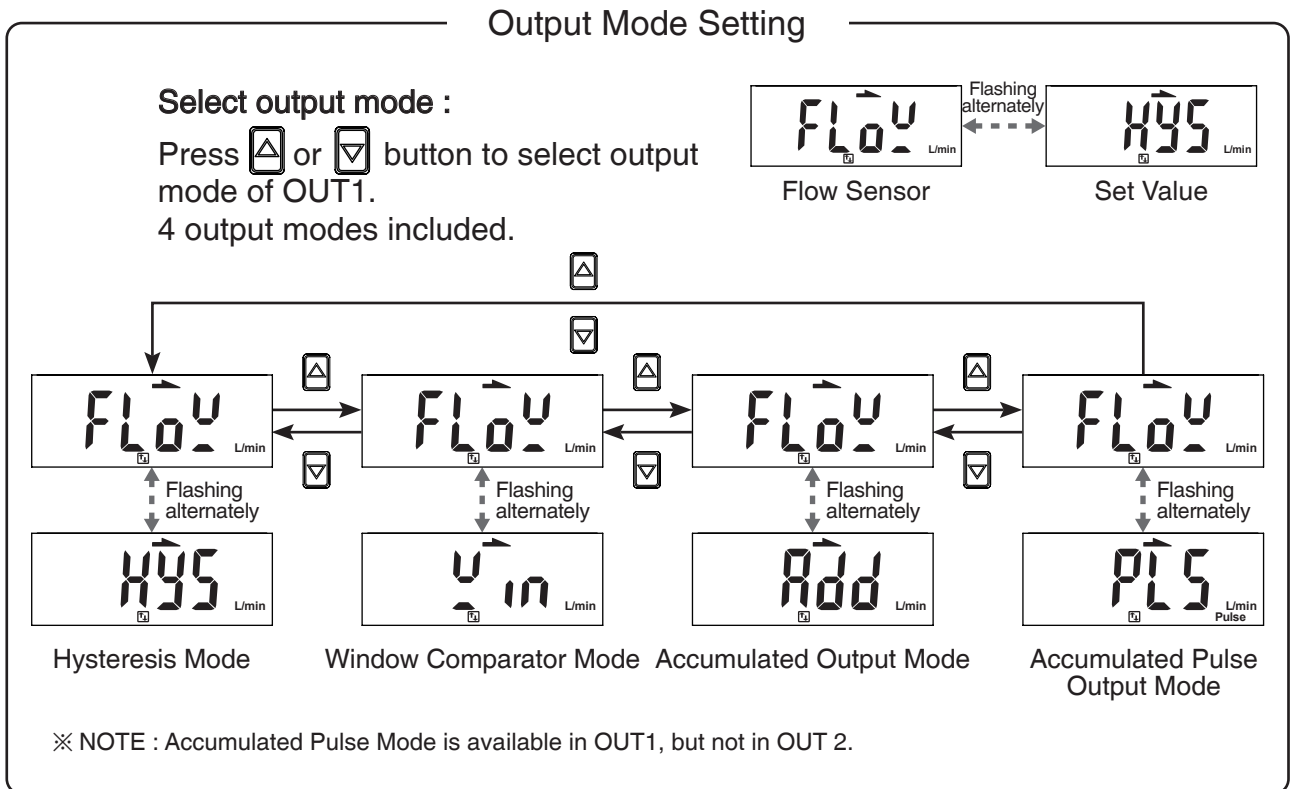

Press button

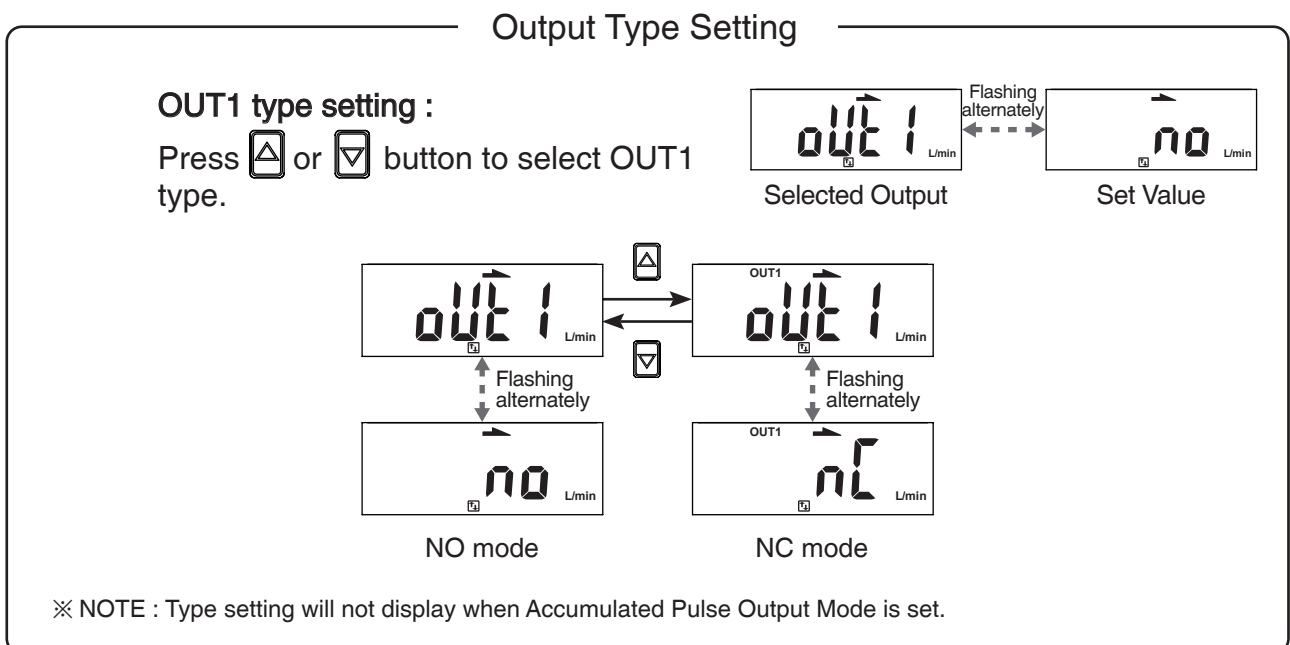

Press  button  (to be continued)

Set Value Setting

OUT1 set value setting :

Press  or  button to adjust the set value.

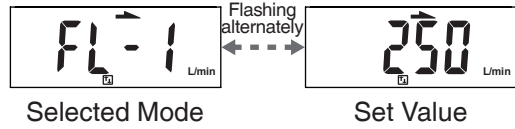

- Hysteresis Mode [HYS] : [FL- 1]
- Window Comparator Mode [W.C] : [FL- 1]
- Accumlated Output Mode [Rdd] : [RdL 1]

※ NOTE : Set value setting will not display when Accumulated Pulse Output is set.

Press  button 

Set Value Setting

OUT1 set value setting :

Press  or  button to adjust the set value.

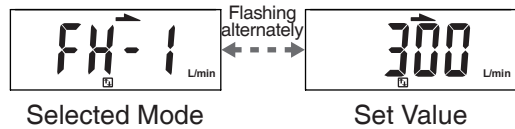



- Hysteresis Mode [HYS] : [FH- 1]
- Window Comparator Mode [W.C] : [FH- 1]
- Accumlated Output Mode [Rdd] : [RdH 1]

※ NOTE : Set value setting will not display when Accumulated Pulse Output is set.

Press  button 

Fixed Hysteresis Setting

Fixed hysteresis setting :

Press  or  button to adjust fixed hysteresis value.

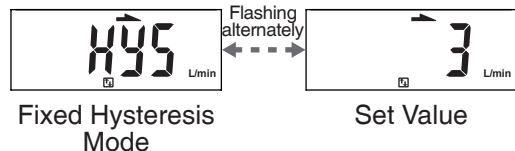

※ NOTE : Fixed hysteresis setting is available when selecting Window Comparator Mode.

Press  button to return to Function Selection Mode 

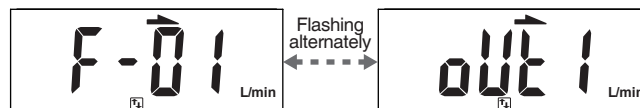

2.3.2 [F-02] OUT2 Setting

Press or button at Function Selection Mode to display [F-02] [OUT2].

Press button

Output Mode Setting

Select output mode :

Press or button to select output mode of OUT2.
3 output modes included.

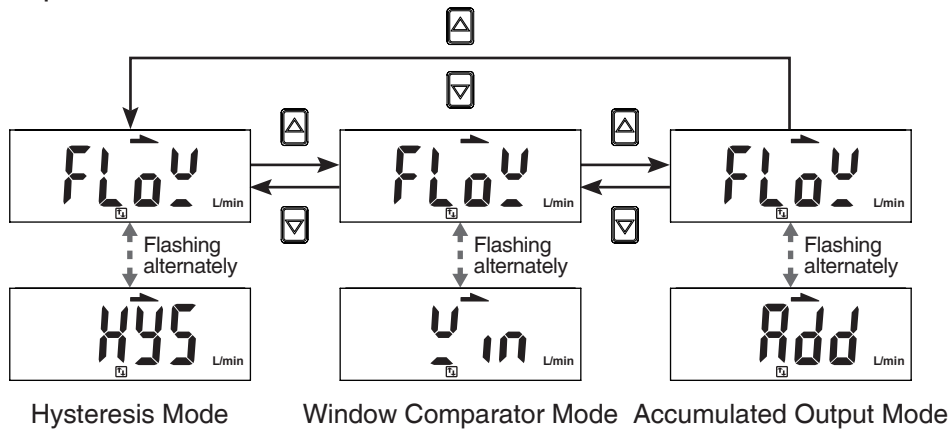
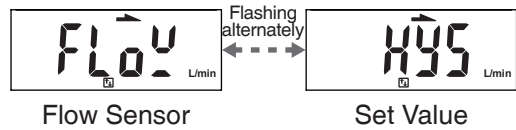

※ NOTE : Accumulated Pulse Mode is available in OUT1, but not in OUT 2.

Press button

Output Type Setting

OUT2 type setting :

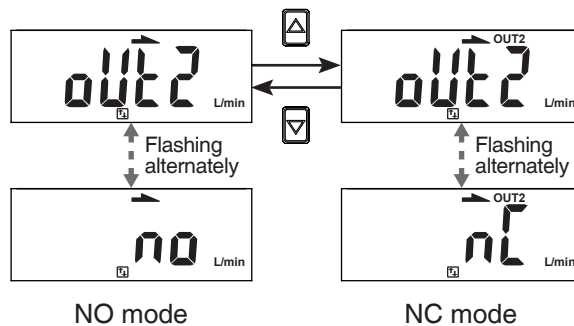
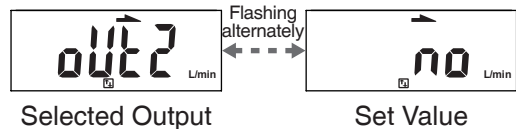

Press or button to select OUT2 type.



Press  button  (to be continued)

Set Value Setting

OUT2 set value setting :

Press  or  button to adjust the set value.

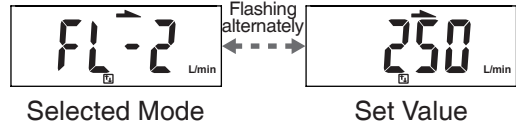

- Hysteresis Mode [HYS] : [FL-2]
- Window Comparator Mode [W.C] : [FL-2]
- Accumulated Output Mode [Add] : [AddL2]

Press  button 

Set Value Setting

OUT2 set value setting :

Press  or  button to adjust the set value.

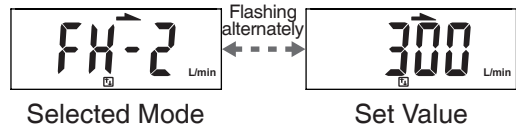



- Hysteresis Mode [HYS] : [FH-2]
- Window Comparator Mode [W.C] : [FH-2]
- Accumulated Output Mode [Add] : [AddH2]

Press  button 

Fixed Hysteresis Setting

Fixed hysteresis setting :

Press  or  button to adjust fixed hysteresis value.

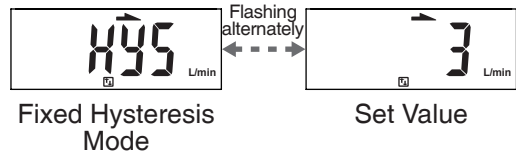

※ NOTE : Fixed hysteresis setting is available when selecting Window Comparator Mode.

Press  button to return to Function Selection Mode 

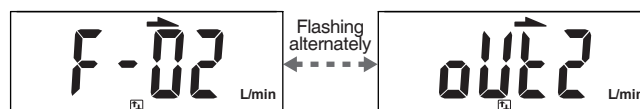

Normal Open Mode

Hysteresis Mode

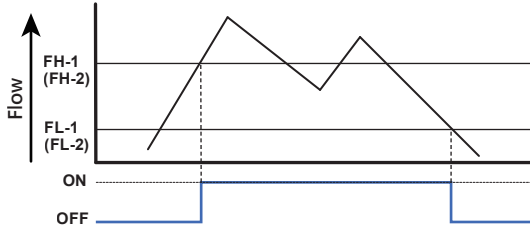

Normal Close Mode

Hysteresis Mode

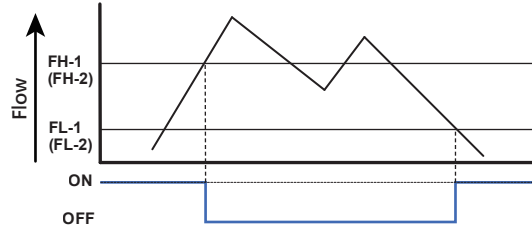

Window Comparator Mode

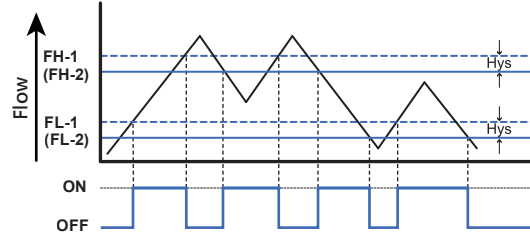

Window Comparator Mode

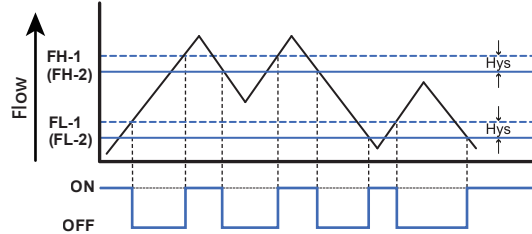

Accumulated Output Mode

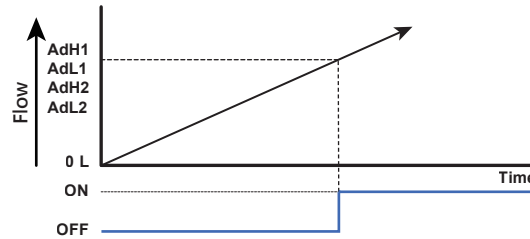

Accumulated Output Mode

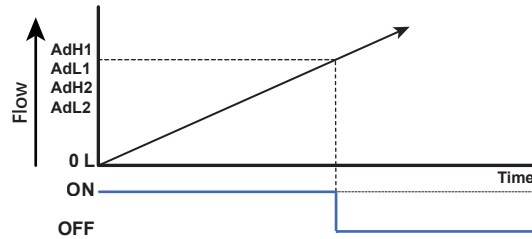

Accumulated Pulse Output Mode

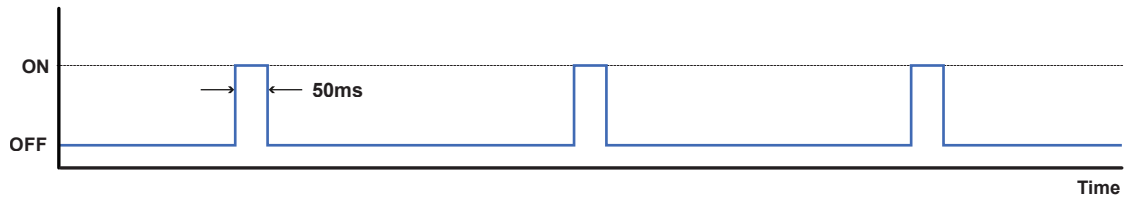

Flow Range	500L	1000L	2000L
Pulse Output Rate	5L	10L	10L

[NOTE:]

- *1. In case hysteresis is set at less than or equal to 2 digits, switch output may chatter if input detected fluctuates near the set point.
- *2. When using window comparator mode, the difference between two set points must be greater than the fixed hysteresis, otherwise will cause the switch output to malfunction.

2.3.3 [F-03] LCD Display Color Setting

4 LCD Display Color Modes of output value selection.

Press or button at Function Selection Mode to display [F-03] [Color].

Press button

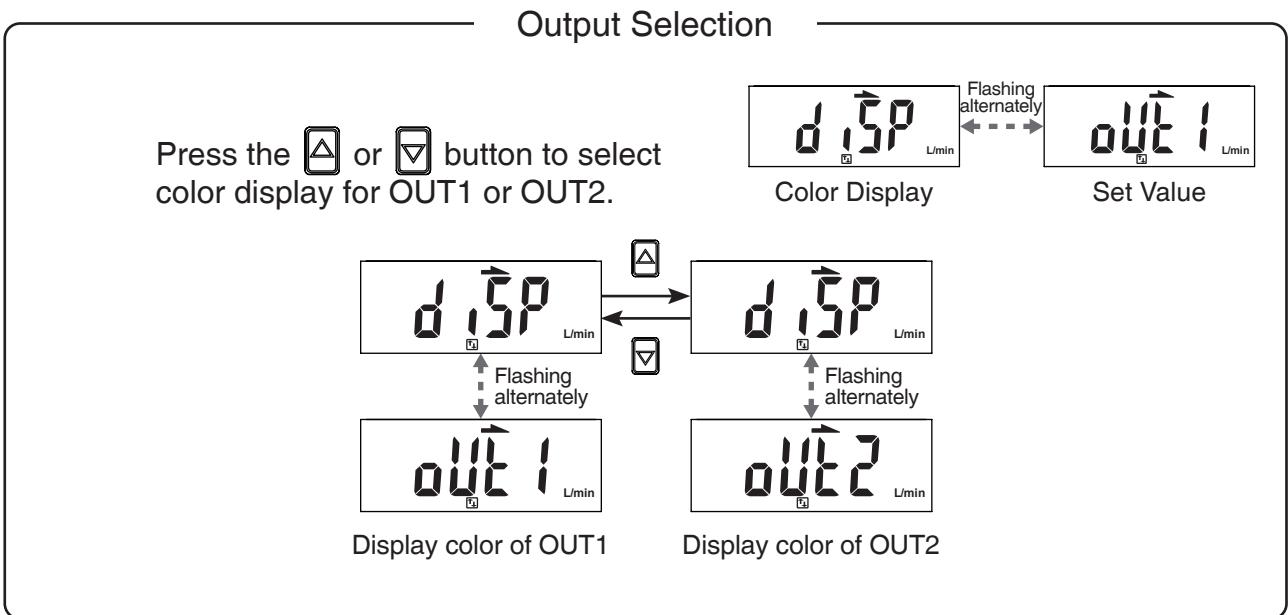

Press button

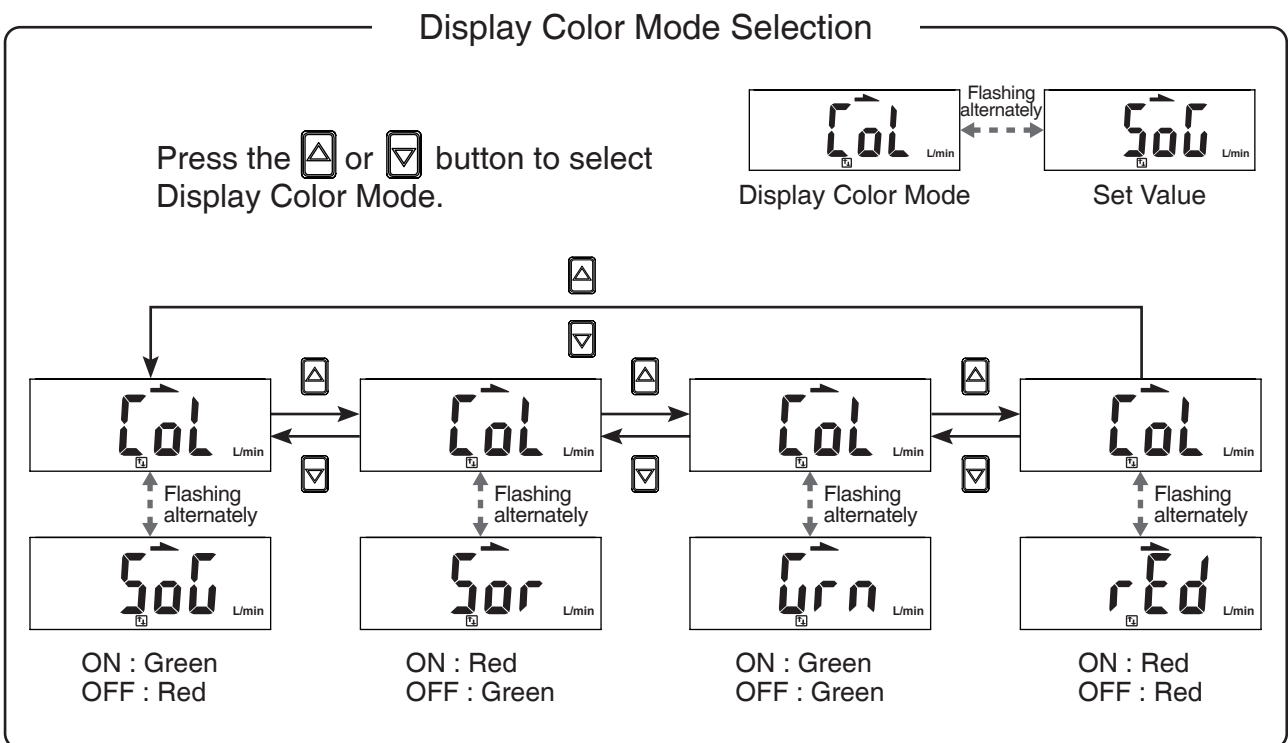

Press  button to return to Function Selection Mode

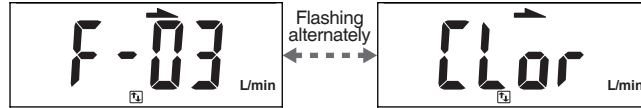

2.3.4 [F-04] Response Time Setting

Select proper response time to avoid switch output chattering.

Press or button at Function Selection Mode to display [F-04] [rESP].

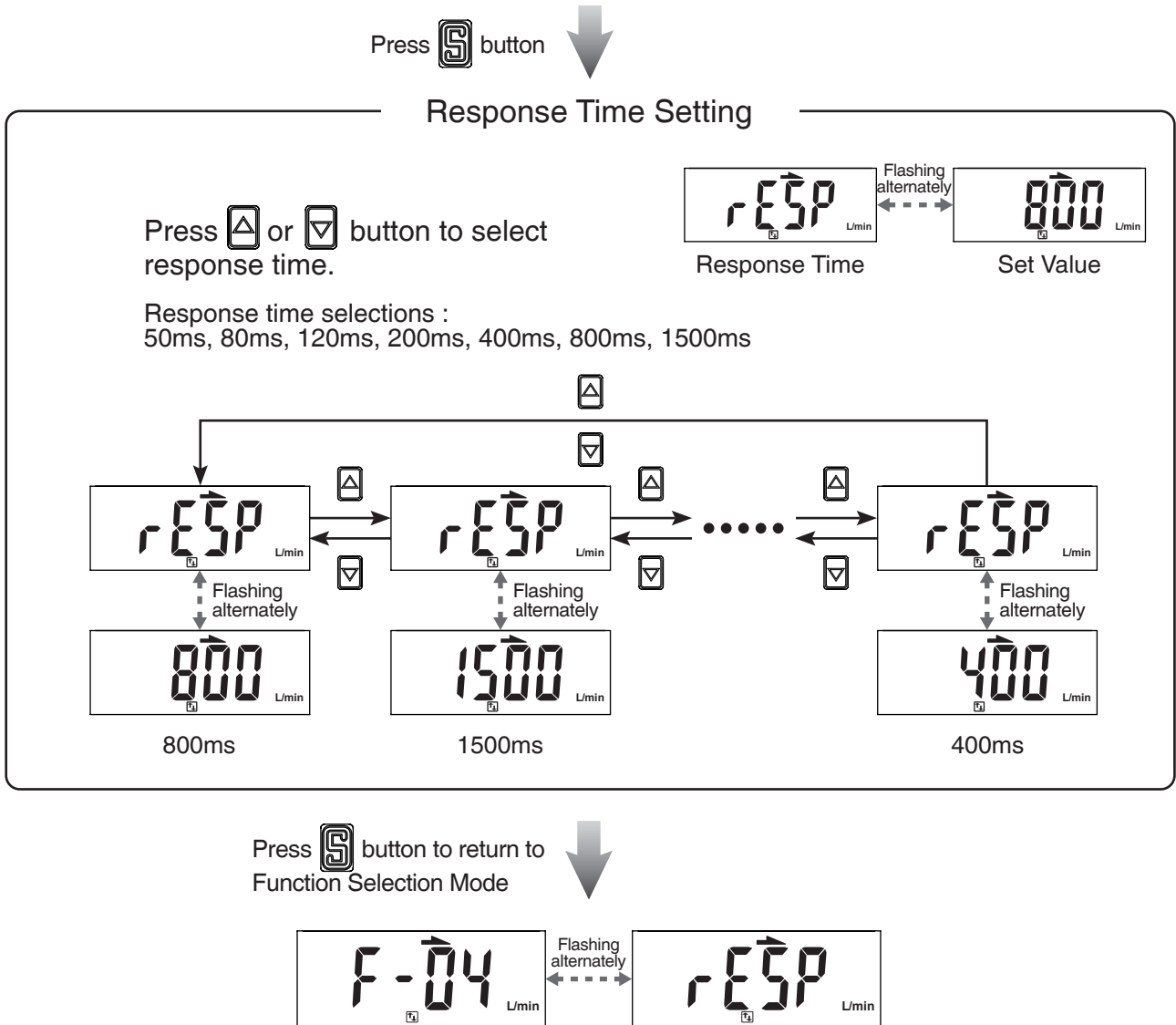

2.3.5 [F-05] Display Refresh Time Setting

Select the proper display refresh time to reduce frequently changing value.

Press or button at Function Selection Mode to display [F-05] [UPdA].

Press button



Display Refresh Time Setting

Press or button to select refresh time.

Display refresh time selections :
200ms, 500ms, 1000ms

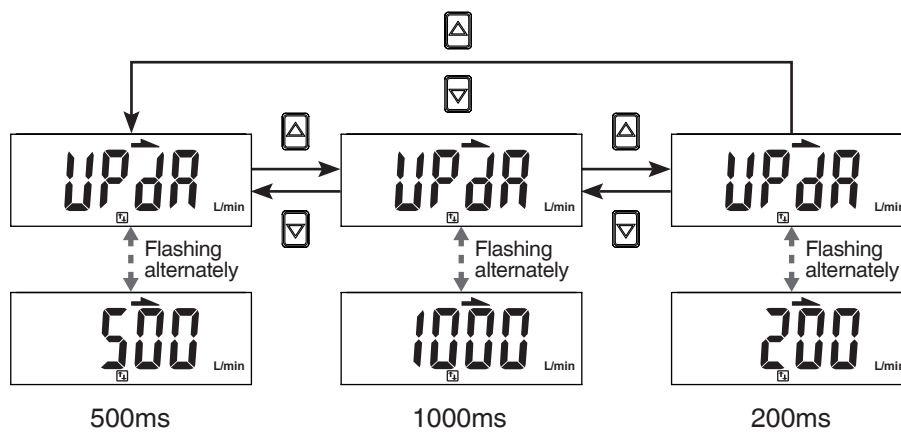
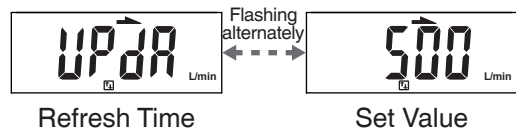

Press button to return to Function Selection Mode



2.3.6 [F-06] Unit Setting

Select the flow unit of the sensor.

Press or button at Function Selection Mode to display [F-06] [Unit].

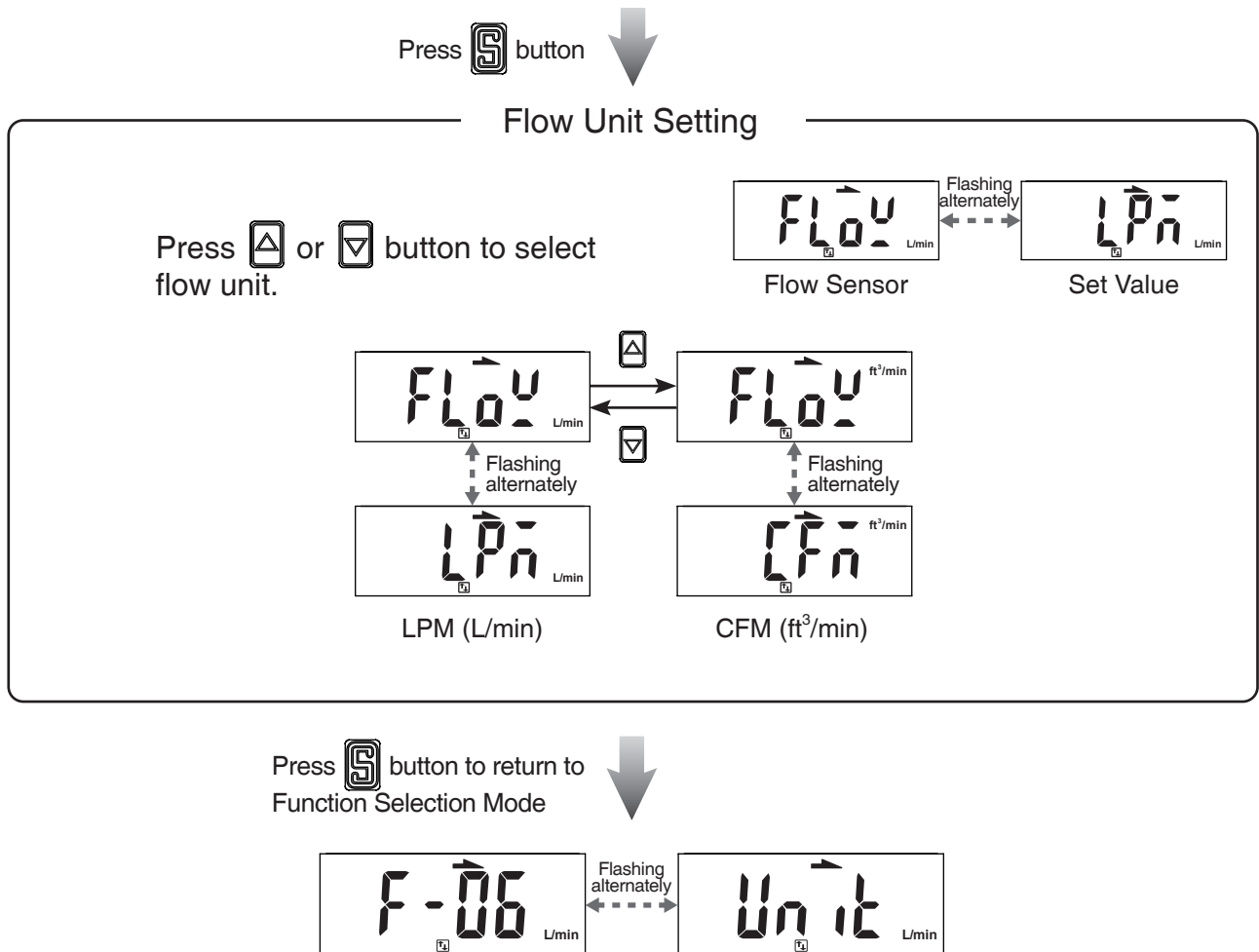

2.3.7 [F-07] Flow Reference Standard Setting

Select the flow value is shown under standard or normal condition.

Press or button at Function Selection Mode to display [F-07] [rEFE].

Press button



Flow Reference Standard Setting

Press or button to select the standard or normal condition.

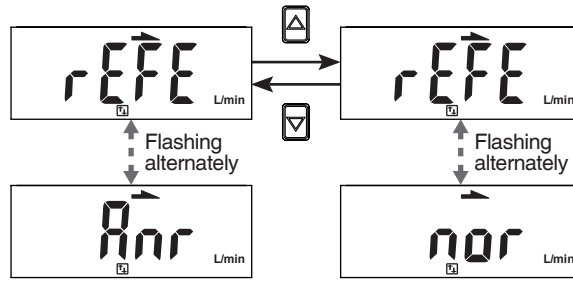
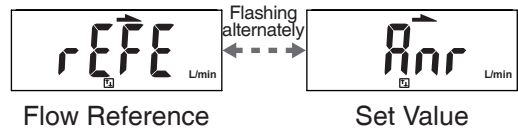

Standard conditon (ANR) Normal condition (NOR)

※ NOTE :

1. Standard condition (ANR): the display value is calculated under 20°C, 1atm.
2. Normal condition (NOR): the display value is calculated under 0°C, 1atm.
3. Flow rate in the specification is the value at standard condition (ANR).

Press button to return to Function Selection Mode

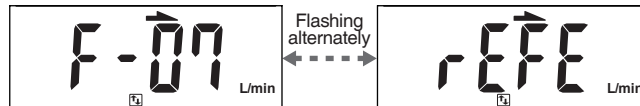

2.3.8 [F-08] Display rotation

Rotate the display vertically.

Press  or  button at Function Selection Mode to display [F-08] [rotA].

Press  button

Display Rotation

Press  or  button to set display rotation.

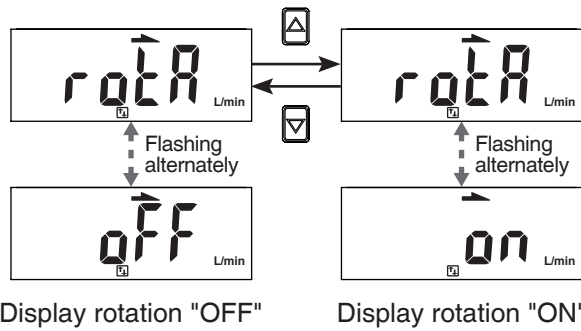
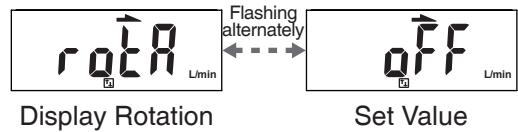

Press  button to return to Function Selection Mode

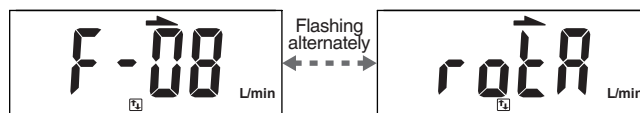

2.3.9 [F-09] Accumulated Value Hold Setting

The default setting is "OFF", the accumulated flow value is zeroed when the power supply is turned off.

Select this function to keep accumulated flow value to be stored in permanent memory and reload the recent saved accumulated value after power supply turns on.

Press or button at Function Selection Mode to display [F-09] [EEP_r].

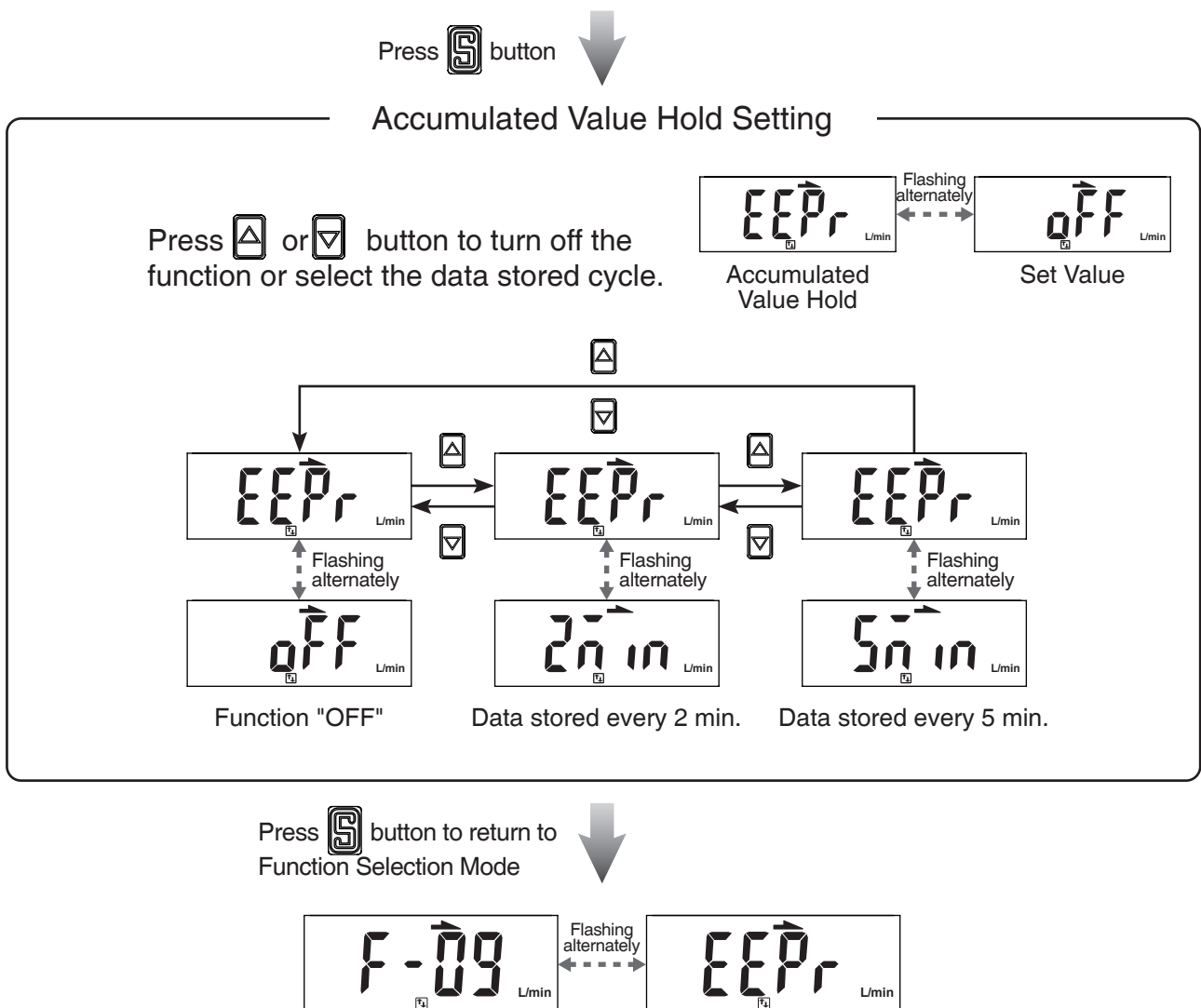

※ NOTE :

The maximum writable limit of the memory device is 1 million cycles.

If the sensor is operated 24 hours per day, the durability is calculated as below:

- ◆ 5 minutes x 1 million cycles = 5 million minutes = 9.5 years
- ◆ 2 minutes x 1 million cycles = 2 million minutes = 3.8 years

2.3.10 [F-10] Flow Sensor Display Mode Setting

Select to display Instantaneous Flow or Accumulated Flow Mode.

Press  or  button at Function Selection Mode to display [F-10] [d15].

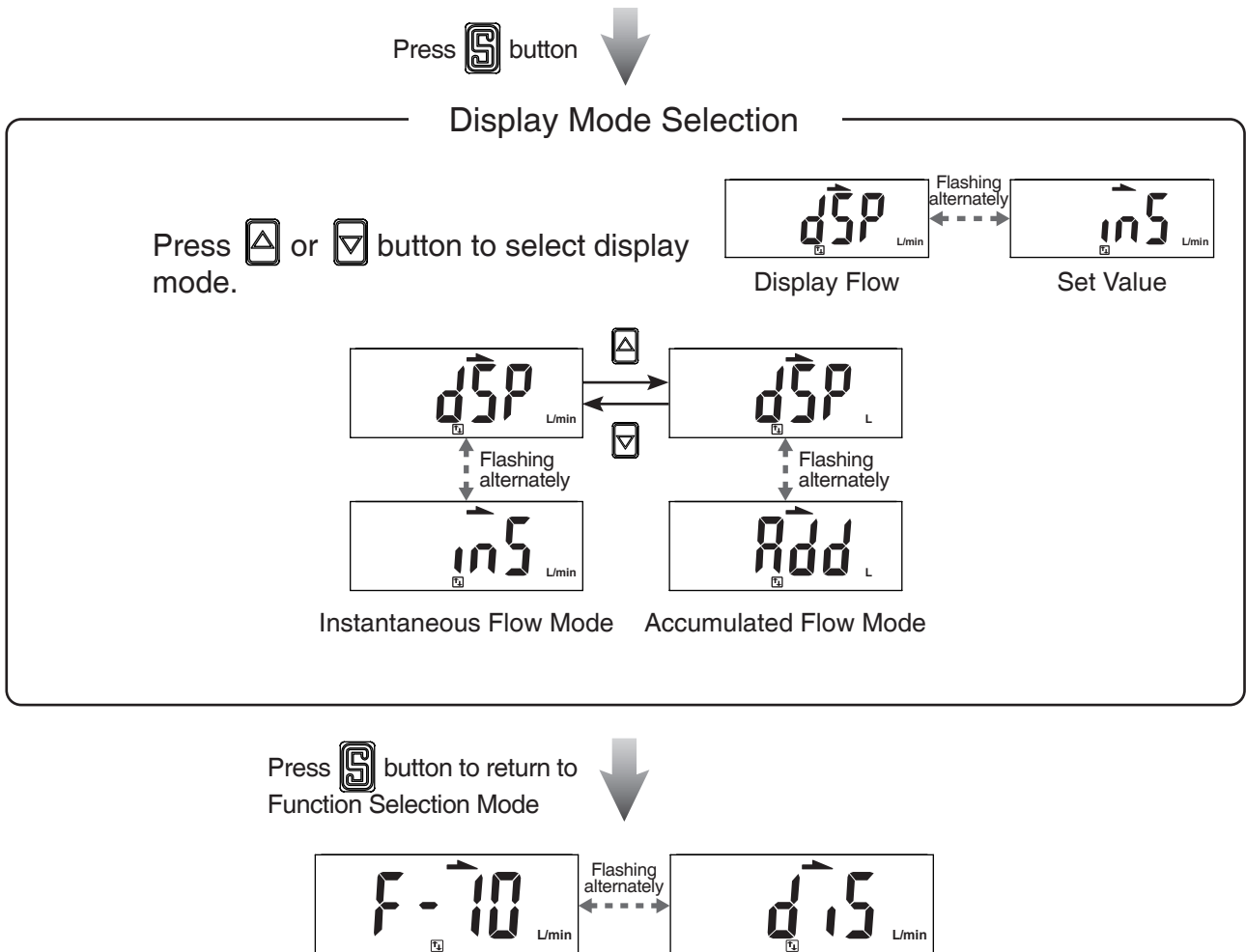

2.3.11 [F-80] Sync the value of flow analog output and display

Turn ON to synchronize the value of flow analog output and display.

Press or button at Function Selection Mode to display [F-80] [59n].

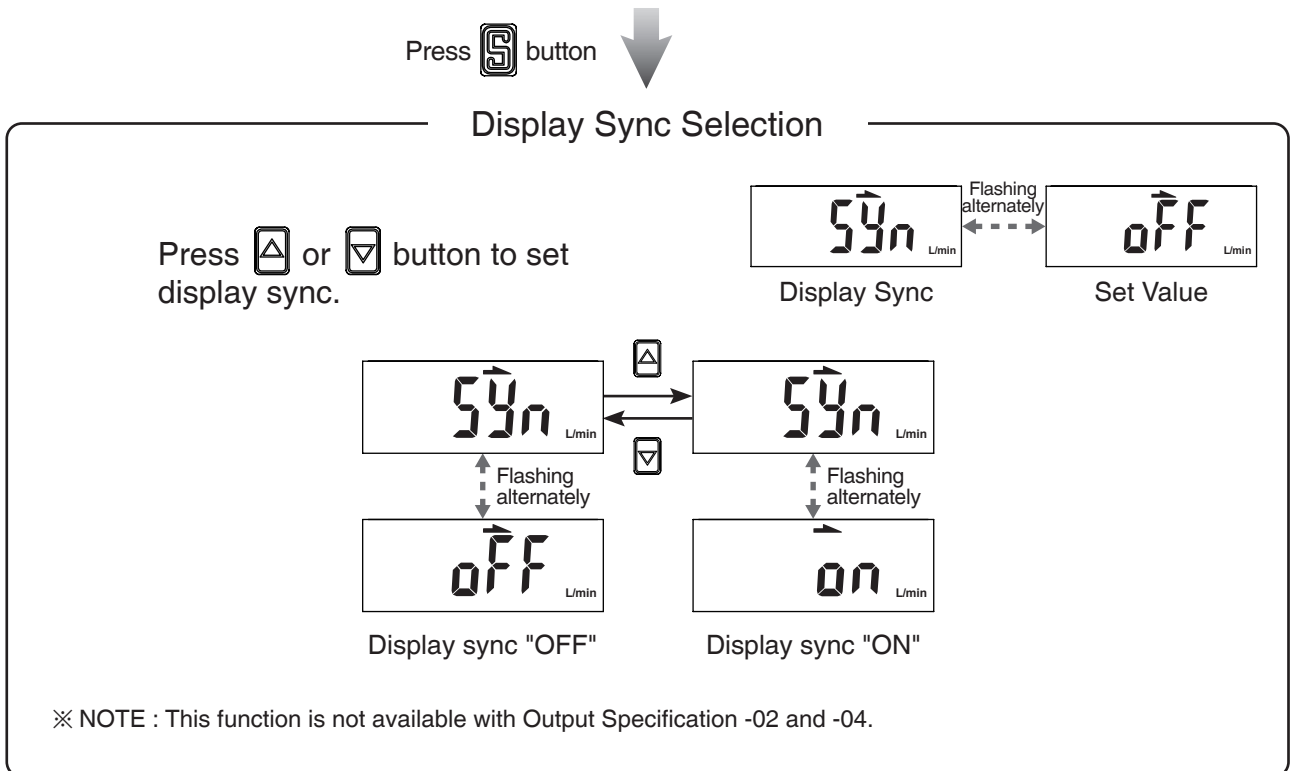

Press button to return to Function Selection Mode ↓

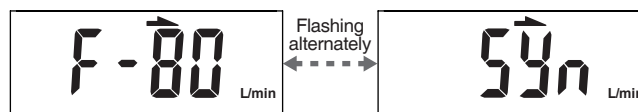

2.3.12 [F-90] Analog Output Range Setting

Set the desired flow range within the display range, which corresponds to the analog output range. Default setting is the measured flow rate range.

Press or button at Function Selection Mode to display [F-90] [Rout].

Press button

Analog Output Range Setting

Press or button to set analog output range.

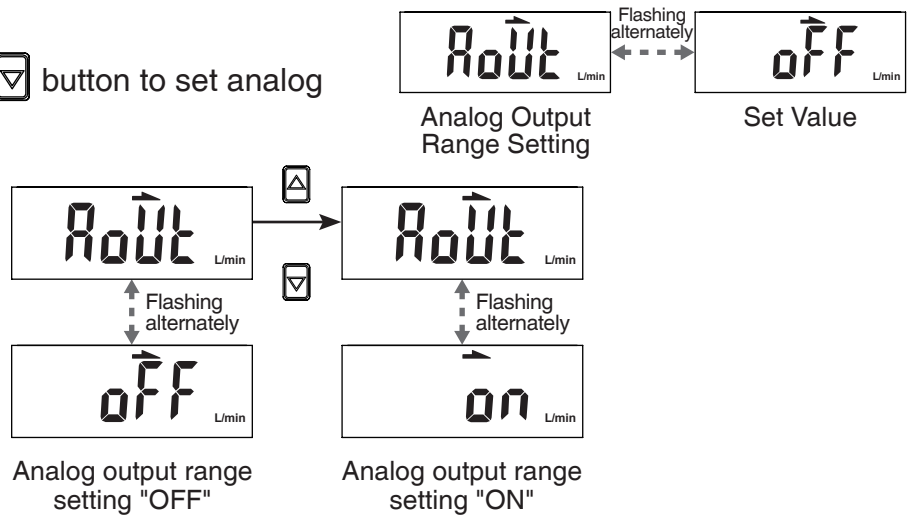

※ NOTE :

1. This function is not available with RS485 (Output Specification -02 and -04).
2. The sensor will return to [F-90] [Rout] when select OFF.

Press button

Range Setting

Min. setting value :

Press or button to adjust the min. value.

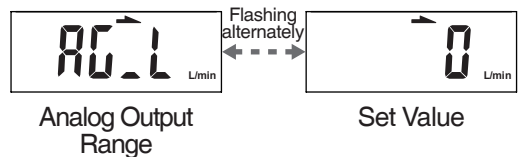



Press button (to be continued)

Range Setting

Max. setting value :

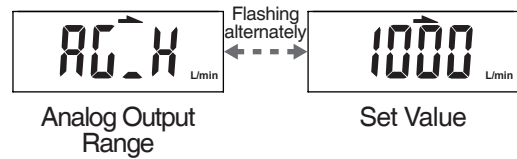
Press  or  button to adjust the max. value.



Press  button to return to Function Selection Mode

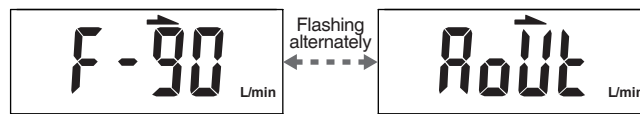

Max. / Min. Value Setting

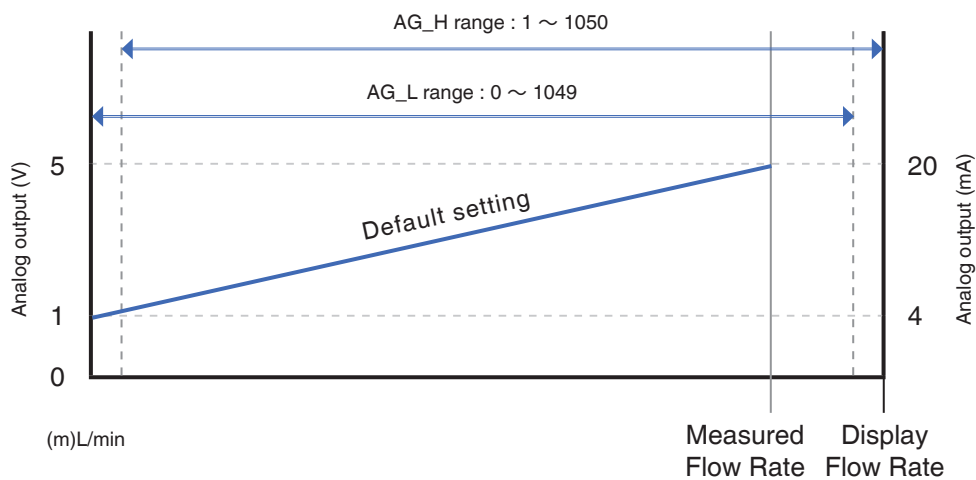

Flow range Settable range	500L	1000L	2000L
AG_L	0 ~ 524	0 ~ 1049	0 ~ 2099
AG_H	1 ~ 525	1 ~ 1050	1 ~ 2100

e.g. : Measured flow rate range 0 ~ 1000L

- ◆ AG_L range : AG_L ~ AG_H - 1 digit
- ◆ AG_H range : AG_L + 1 digit ~ AG_H

2.3.13 [F-9 1] Power-Save Mode Setting

Select Power-Save Mode at Measurement Mode.

During the Power-Save Mode, the main display will turned off if no buttons is pressed in 30 sec., press any keys to leave the Power-Save Mode.

Press or button at Function Selection Mode to display [F-9 1] [ELo].

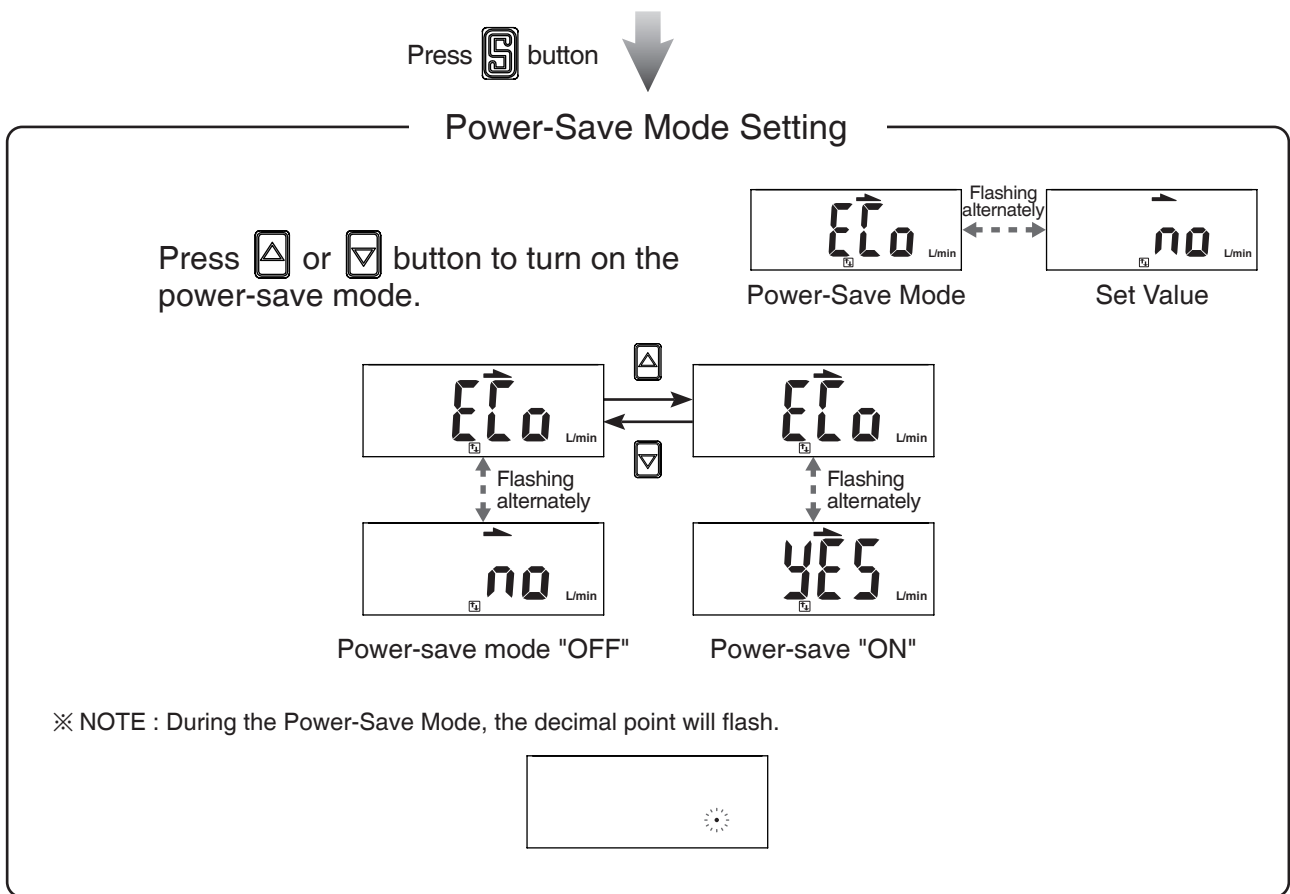

Press button to return to Function Selection Mode

↓

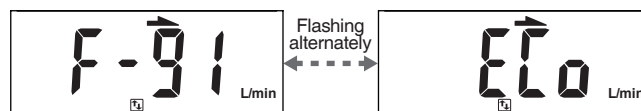

2.3.14 [F-92] External Input Setting

Accumulated flow external reset : The accumulated flow value will reset to "0" when an external input signal is applied.

Auto-shift : The instantaneous flow rate will regard as the standard when the external input signal is applied. The switch output function operates relative to its change.

Auto-shift zero : The instantaneous flow rate is reset to zero to regard as standard when the external input signal is applied.

The switch output function operates relative to its change.

This function is only for output 1 corresponding to flow sensor action point. When external signal is input, please connect the input wire to GND for 30 ms or more.

Press or button at Function Selection Mode to display [F-92] [inP].

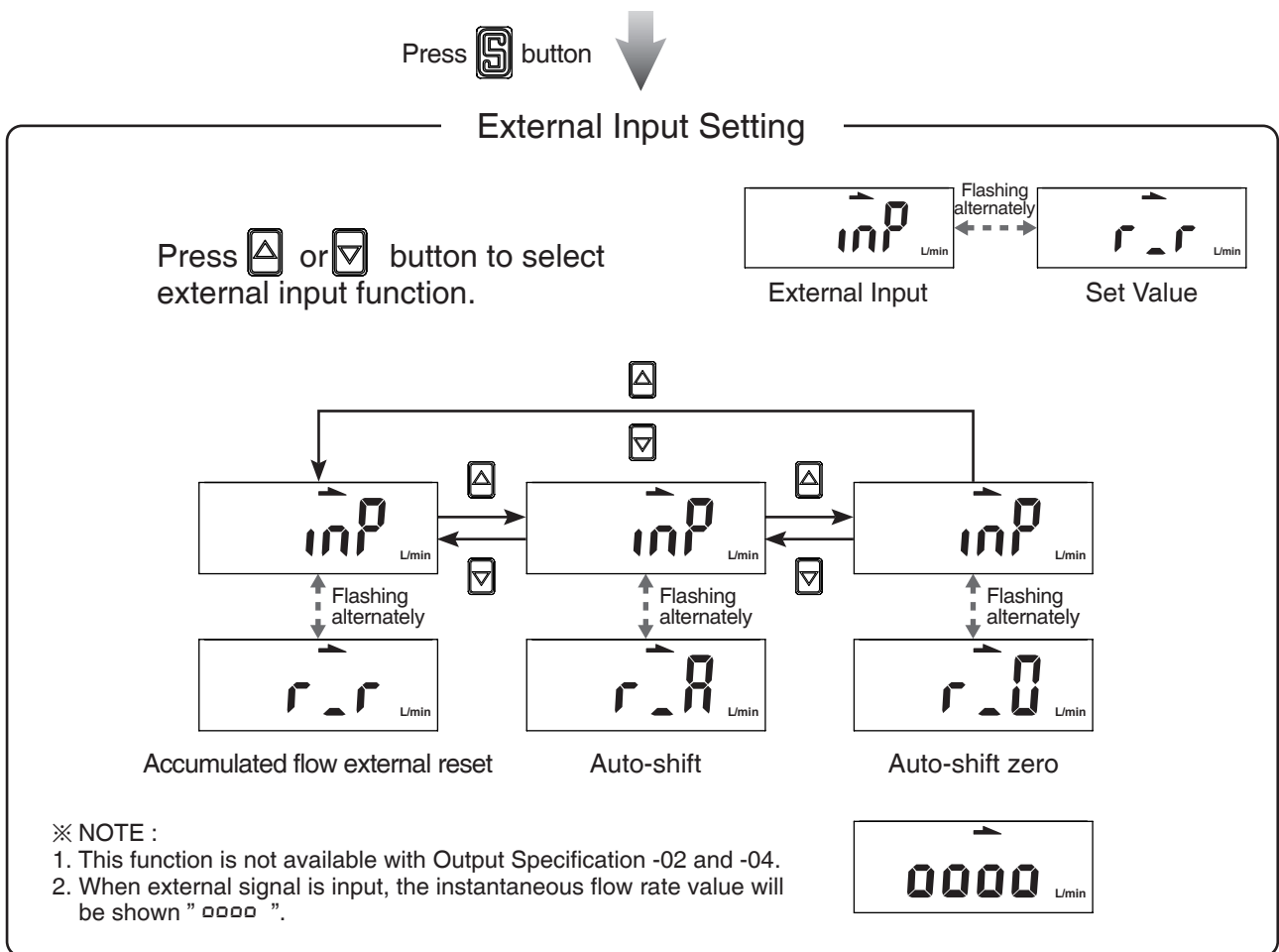

2.3.15 [F-93] Modbus RTU Setting

MODBUS transmission protocol can be set according to user requirements.

Press or button at Function Selection Mode to display [F-93] [MODBUS].

Press button

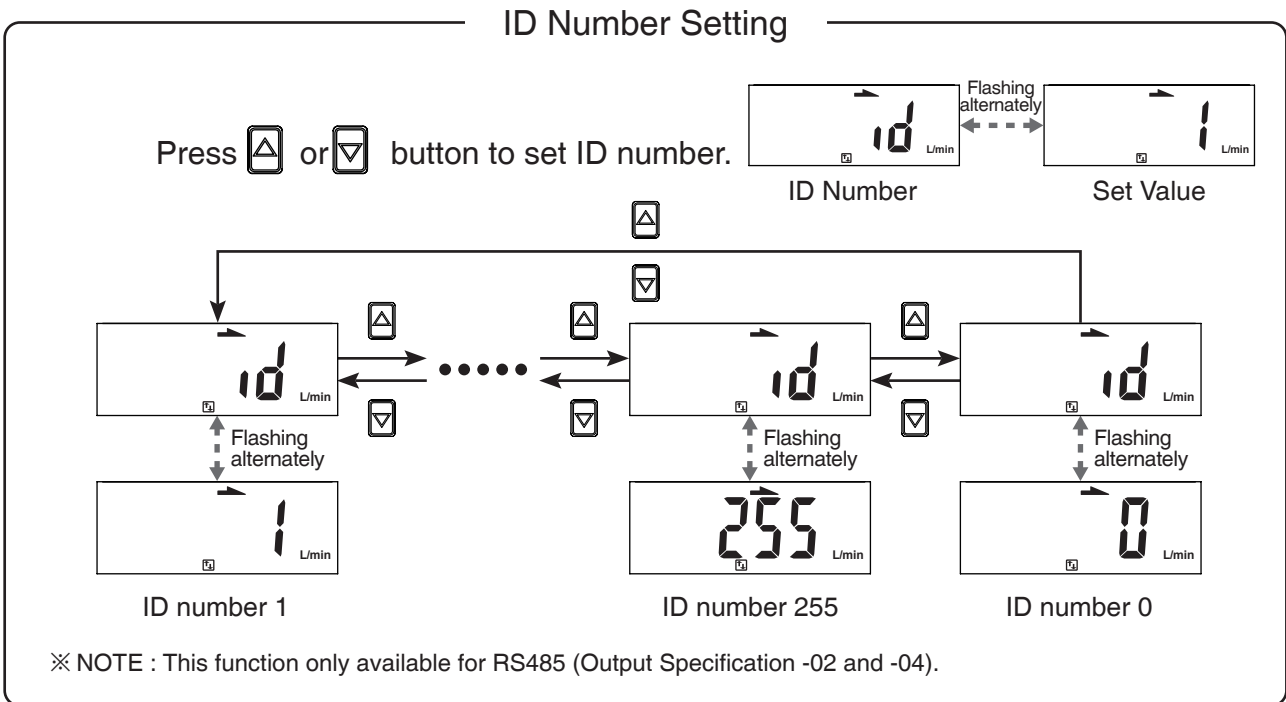

Press button

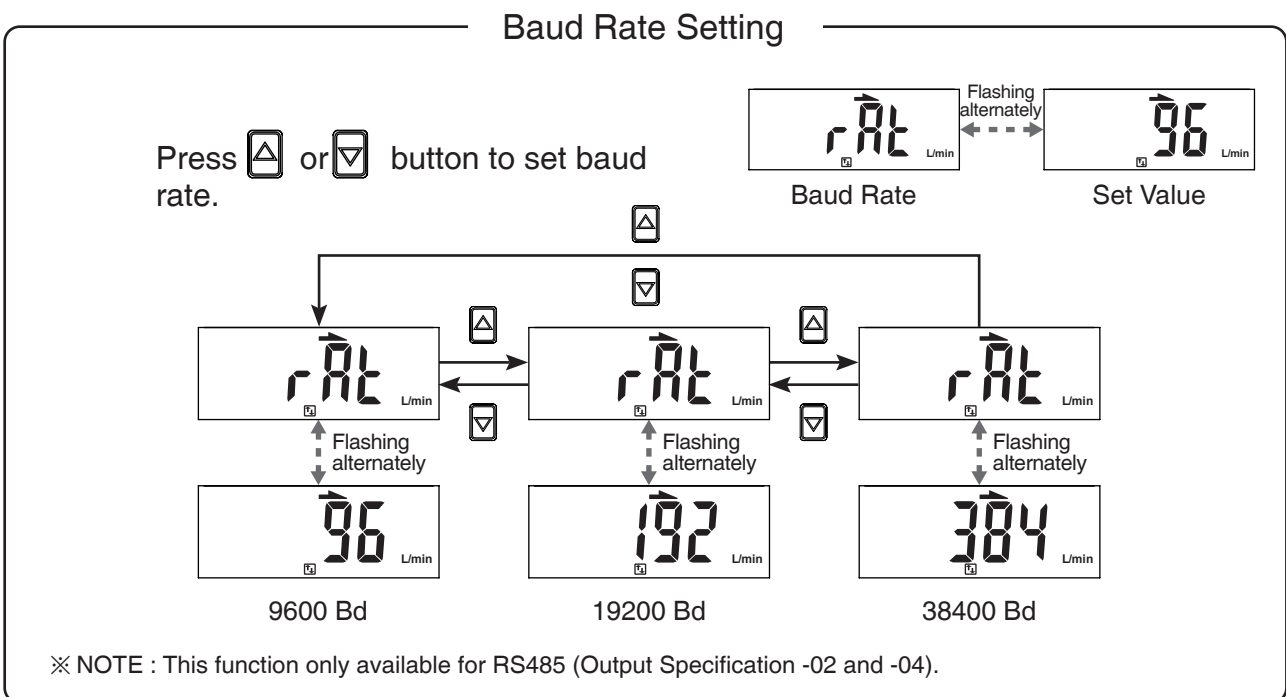

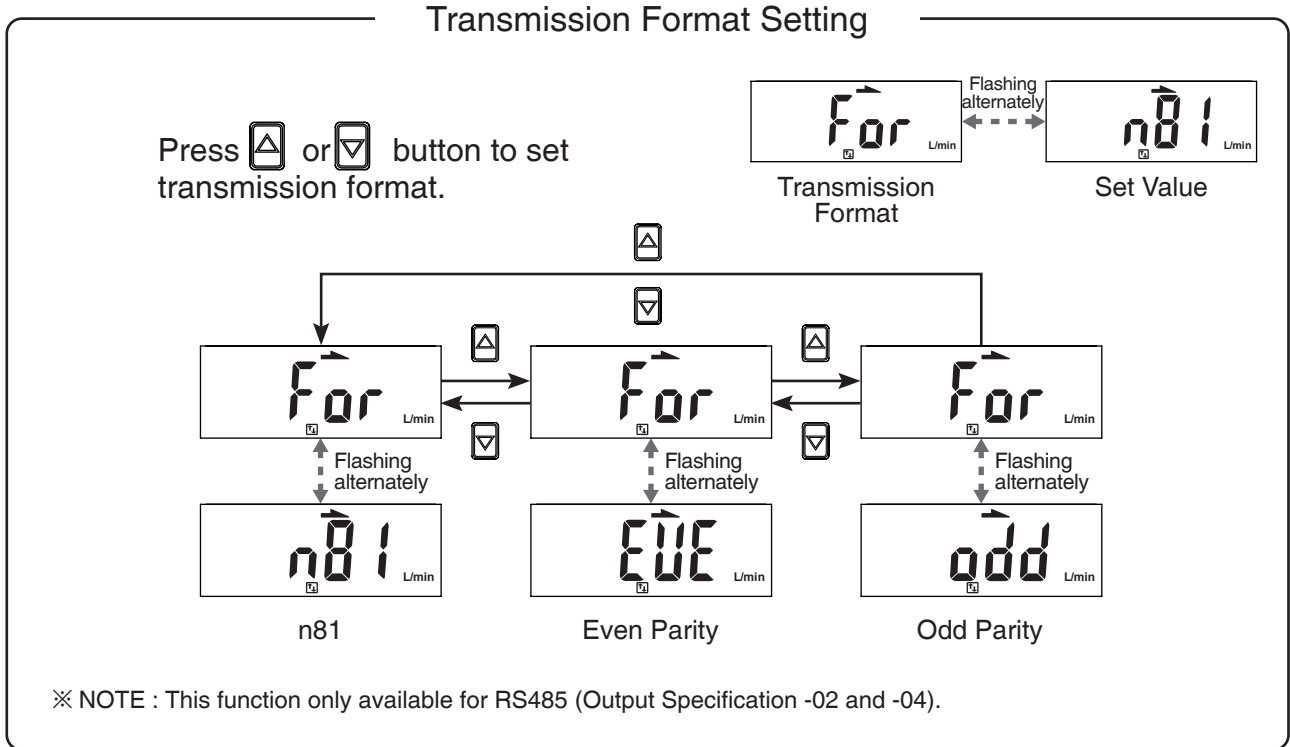

Press  button  (to be continued)

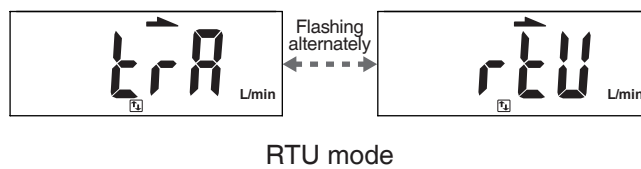

Press  button 



Press  button to return to Function Selection Mode 



2.3.16 [F-94] Fine Adjustment Setting

This function is to fine adjust flow and pressure display values.



Display values can be calibrated to within $\pm 2.5\%$ R.D.

Press  or  button at Function Selection Mode to display [F-94] [F inE].

Press  button



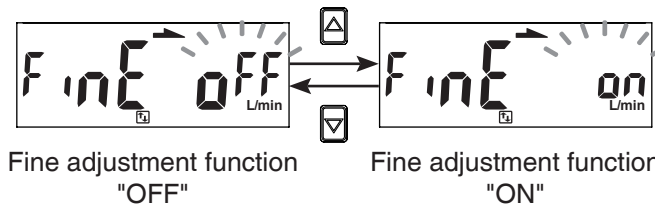
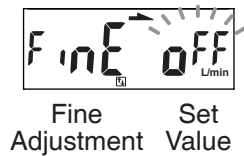

Fine Adjustment Setting

Press  or  button to select fine adjustment OFF or to set fine adjustment instantaneous flow rate value or pressure value.



Fine Adjustment of Instantaneous Flow Rate Value

Press  or  button to set fine adjustment value.

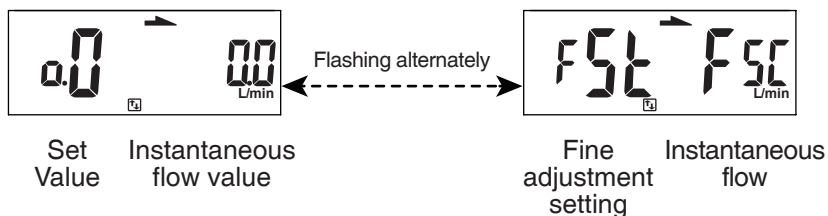

Press  button



Return to the measurement mode

2.3.17 [F-95] Forced Output Function

To force output ON/OFF to test the switch function.

Press or button at Function Selection Mode to display [F-95] [F_{OUT}].

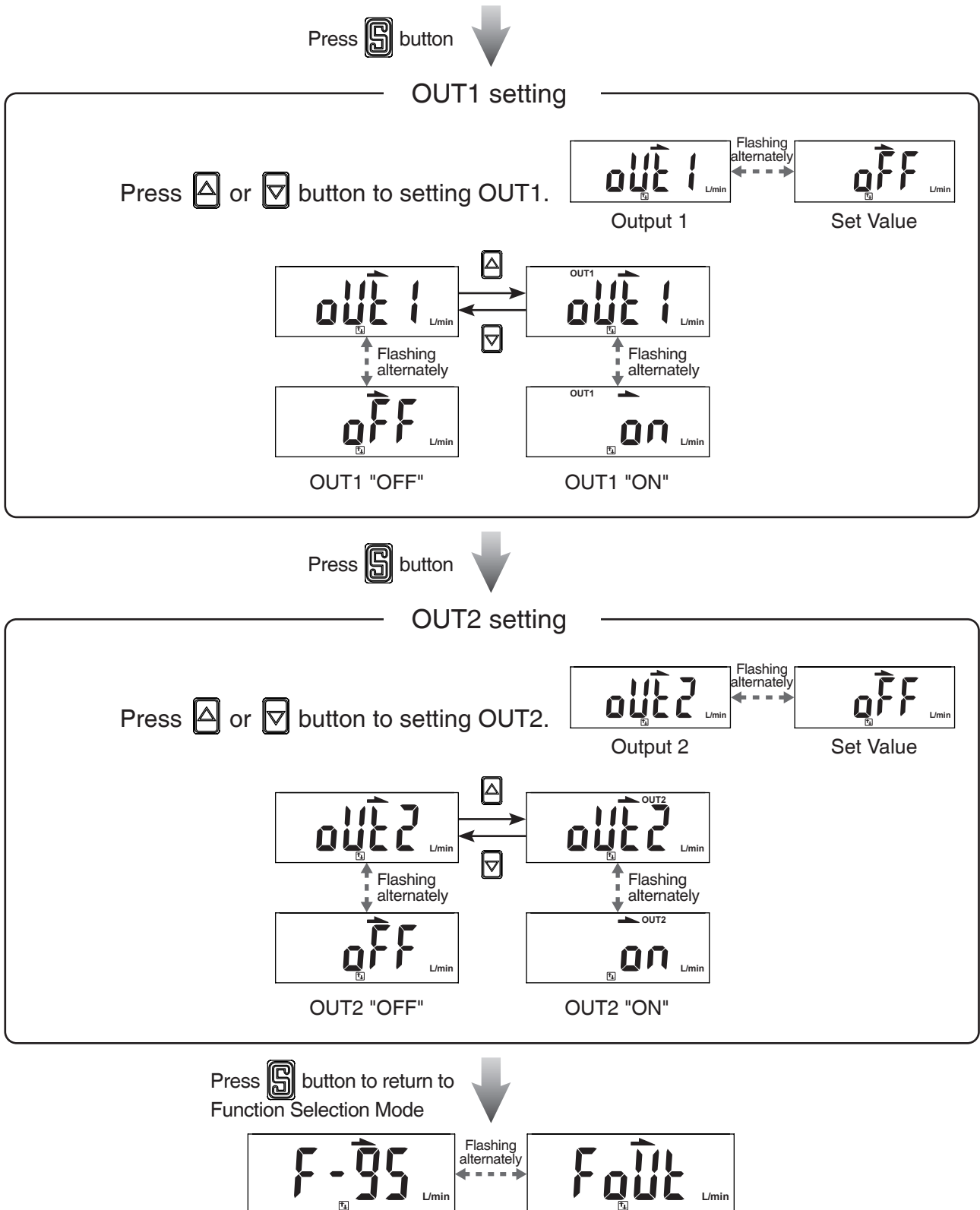

2.3.18 [F-99] Reset to the Default Setting

The factory default settings can be restored.

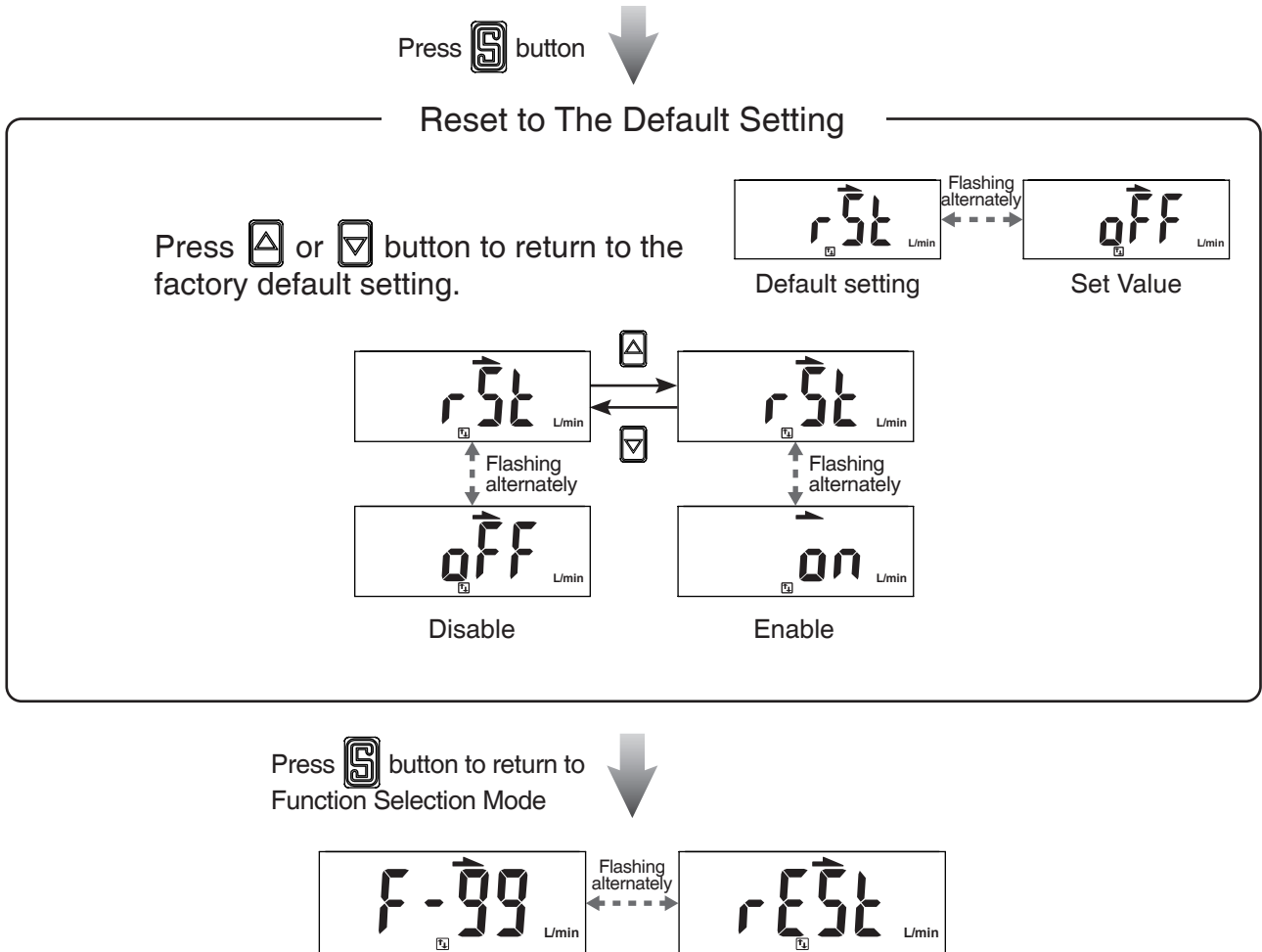

Press or button at Function Selection Mode to display [F-99] [rESt].



2.3.19 Instantaneous Flow Zero Adjustment Function

The displayed value can be adjusted to "0" when the measured flow is within $\pm 5\%$ F.S. of the zero point at the time of shipment from the factory.

< Operation >

Press  and  button simultaneously over 3 sec. at the measurement mode (not Accumulated flow value display mode) until display [00].

And release holding the button to return measurement mode.

Measurement mode

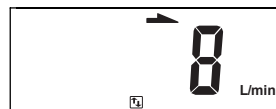

Press  and  button simultaneously over 3 sec.



To release holding the button to return measurement mode.

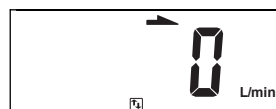



Instantaneous flow value return zero.

2.3.20 Reset Accumulated Flow Function

Accumulate flow value return to zero.

< Operation >

Press  and  button simultaneously over 3 sec. at the measurement mode (Accumulated flow value mode) until display zero.

And release holding the button to return measurement mode.

Measurement mode



Press  and  button simultaneously over 3 sec.





Accumulated value display zero.
To release holding the button to
return measurement mode.

2.3.21 Peak Value Display

The maximum pressure and instantaneous flow, from when the power was supplied to this moment, is detected and updated.

< Operation >

Press  button over 3 sec. at the measurement mode. The maximum value will be displayed flashing, and is held.

Press  button return to the measurement mode.

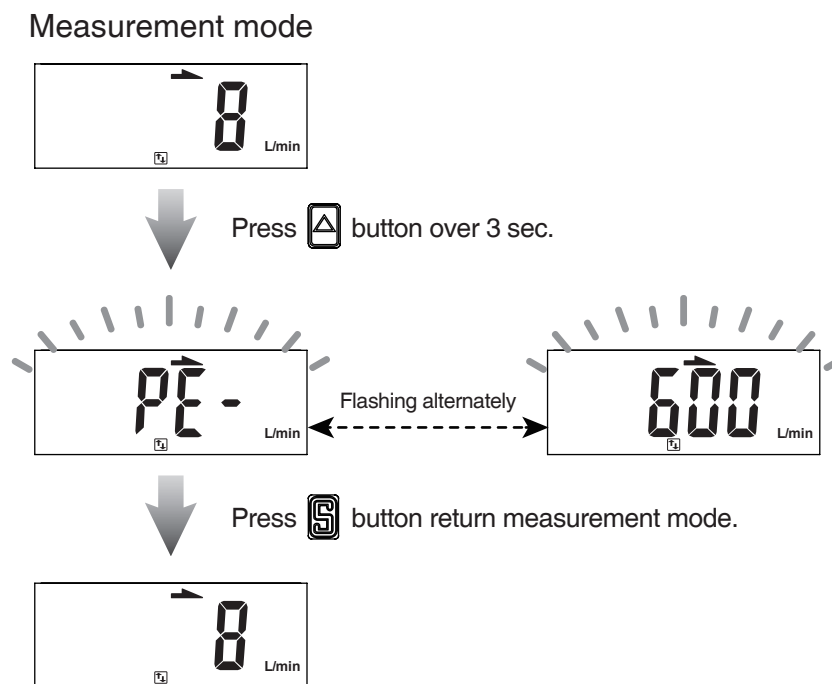

2.3.22 Bottom Value Display

The minimum pressure and instantaneous flow, from when the power was supplied to this moment, is detected and updated.

< Operation >

Press  button over 3 sec. at the measurement mode. The minimum value will be displayed flashing, and is held.

Press  button return to the measurement mode.

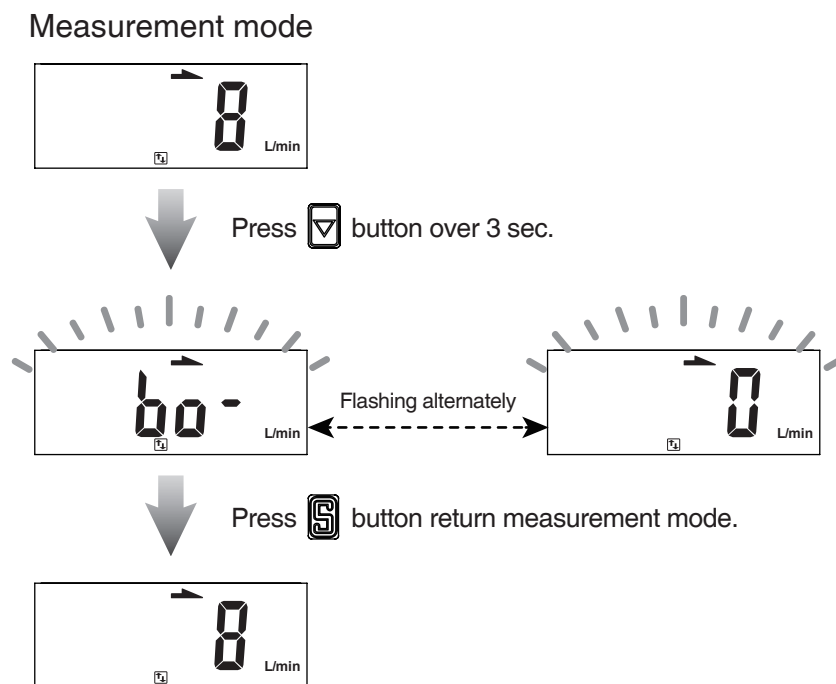

2.3.23 Key Lock Mode

Prevent accidental changes to settings parameters. When lock function is ON and user mistakenly presses button, screen will display [L^oL] [^on] for 1 sec.

< Operation >

Press  button over 5 sec. at measurement mode to select key lock/unlock setting.

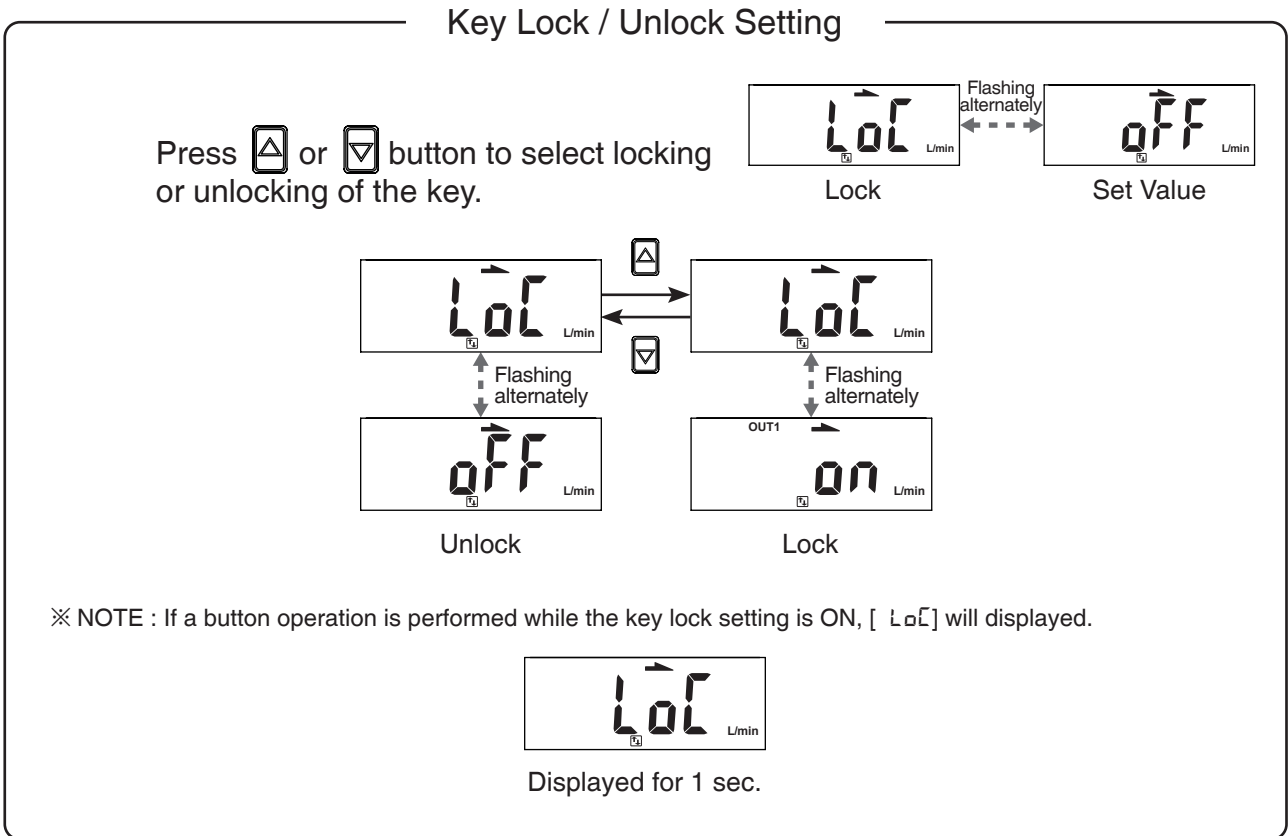

3 Modbus RTU Instruction

Function Code	Explanation	Operation
0000H	ID Number (0 ~ 255) Range : 0 ~ 255	Read Write
0001H	Baud rate setting 0 : 9600 bps 1 : 19200 bps 2 : 38400 bps	Read Write
0002H	Transmission format setting 0 : N.8.1 1 : E.8.1 2 : O.8.1	Read Write
0003H	Communications protocol setting 0 : RTU	Read Write
0004H	Measured flow rate range 7 : 500L/min 8 : 1000L/min 9 : 2000L/min	Read
0005H	Instantaneous flow value	Read
0006H	Flow unit 0 : LPM (L/min or mL/min) 1 : CFM (ft ³ /min)	Read Write
0007H	Decimal place for flow value 0 : None 1 : One decimal place 0.1 2 : Two decimal places 0.01 3 : Three decimal places 0.001	Read
0008H	Accumulated flow value (ADL) XXXX 9999	Read
0009H	Accumulated flow value (ADH) 9999 XXXX	Read
000AH	Flow reference standard 0 : ANR (Standard condition) 1 : NOR (Normal condition)	Read Write

Function Code	Explanation	Operation
000BH	Flow sensor display mode 0 : Instantaneous flow 1 : Accumulated flow	Read Write
000CH	Accumulated value hold 0 : None 1 : 2 min /times 2 : 5 min/times	Read Write
000DH	Flow display refresh time 0 : 200ms 1 : 500ms 2 : 1000ms	Read Write
000EH	Fine adjustment of display value -25 ~ 25 (-2.5% ~ +2.5%)	Read Write
000FH	Response time of flow sensor 0 : 50ms 1 : 80ms 2 : 120ms 3 : 200ms 4 : 400ms 5 : 800ms 6 : 1500ms	Read Write
0010H	OUT1 output mode 0 : HYS (Hysteresis) 1 : WIN (Window Comparator) 2 : ADD (Accumulated Output) 3 : PLS (Accumulated Pulse Output)	Read Write
0011H	OUT1 output type 0 : N.O. mode 1 : N.C. mode	Read Write
0012H	Flow setting value FL-1	Read Write
0013H	Flow setting value FH-1	Read Write
0014H	Flow setting value ADL1	Read Write
0015H	Flow setting value ADH1	Read Write
0016H	OUT1 fixed hysteresis setting for flow value HYS 1 ~ 8	Read Write

Modbus RTU Instruction

Function Code	Explanation	Operation
0017H	OUT1 switch 0 : OFF 1 : ON	Read
0018H	OUT2 output mode 0 : HYS (Hysteresis) 1 : WIN (Window Comparator) 2 : ADD (Accumulated Output)	Read Write
0019H	OUT2 output type 0 : N.O. mode 1 : N.C. mode	Read Write
001AH	Flow setting value FL- 2	Read Write
001BH	Flow setting value FH-2	Read Write
001CH	Flow setting value ADL2	Read Write
001DH	Flow setting value ADH2	Read Write
001EH	OUT2 fixed hysteresis setting for flow value HYS 1 ~ 8	Read Write
001FH	OUT2 switch 0 : OFF 1 : ON	Read
0020H	Color display for OUT1 or OUT2 selection 0 : OUT1 1 : OUT2	Read Write
0021H	Display color setting 0 : SOG (Switch on Green) 1 : SOR (Switch on Red) 2 : GRN (Always is Green) 3 : RED (Always is Red)	Read Write
0022H	Power-save mode 0 : NO 1 : YES	Read Write

Function Code	Explanation	Operation
0023H	Reset to the default setting 0 : RECALL	Write
0024H	Instantaneous flow zero adjustment 0 : When over $\pm 5\%$ F.S., error code 03H will show	Write
0025H	Reset accumulated flow 0 : Accumulated flow value return to zero	Write
0026H	Key lock/unlock setting 0 : OFF 1 : ON	Read Write
0027H	Switch output 0 : NPN 1 : PNP	Read
0028H	Display rotation setting 0 : OFF 1 : ON	Read Write









● Read / Write Code

Read/Write Code	Explanation
03H	Read pressure sensor data Range 1 ~ 4 data Number, 2 ~ 8 Bytes
06H	Write pressure sensor data

● Error Code Description

Error Code	Explanation
01H	Read / Write error
02H	Function Code error
03H	Illegal data or over setting value

4 Error Code Instruction

Error Type	Error Code	Error Condition	Troubleshooting
OUT1 Excess Load Current Error		Output 1 load current is more than 125 mA	Turn power off and check the cause of overload current or lower the current load under 125 mA, then restart.
OUT2 Excess Load Current Error		Output 2 load current is more than 125 mA	
Zero Adjustment Error		The instantaneous flow is over $\pm 5\%$ F.S. of the zero point.	Perform the zero clear function again under no flow conditions.
System Error		Memory error	Turn power off, and then restart. If error condition remains, please return to factory for inspection.
		Internal data error	
		Internal data error	
		System parameter error	
Applied Error		The instantaneous flow has exceeded the upper limit of the flow display range.	Reduce the flow to the display range.
		The instantaneous flow has exceeded the lower limit of the flow display range.	Ensure the flow is in the correct direction.

5 Specifications

Model		501	102	202
Fluid		Dry air, N ₂ , Non-corrosive / Non-flammable gas		
Sensor Element	Measured Flow Rate Range	2 ~ 500 L/min	5 ~ 1000 L/min	10 ~ 2000 L/min
	Flow Direction	Unidirection		
		4 digital (Flow) / 8 digital (Accumulated Flow), 7 segment LCD display (Red / Green / Orange)		
Display	Instant Flow Rate	Display Range	0 ~ 525 L/min	0 ~ 1050 L/min
		Minimum Setting Scale	LPM	1 L/min
			CFM	0.1 ft ³ /min
	Accumulated Flow	Display Range	99999999 L	
Minimum Setting Scale		1 L		
		0.1 ft ³		
Accuracy	Guaranteed Range	2 ~ 100 % F.S.		
	Indicator Accuracy	± 3% F.S. ± 1 digit *1		
	Analog Output Accuracy	± 5% F.S. *1		
	Repeatability	± 1% F.S. ± 1 digit (± 2 % F.S. when response time is set to 50 ms) *2		
	Linearity	± 3% F.S. *2		
	Temp. Characteristic	± 5% F.S. *2		
	Pressure Characteristic	± 5% F.S. ± 1 digit *3		
Switch Output	Output Mode	2 NPN : open collector 2 outputs Max. Load Current : 125 mA Max. Supply Voltage : 24 V DC Voltage Drop : ≤ 1.5 V		
		2 PNP : open collector 2 outputs Max. Load Current : 125 mA Max. Supply Voltage : 24 V DC Voltage Drop : ≤ 1.5 V		
	Output Mode	Hysteresis Mode, Window Comparator Mode, Accumulated Output, Accumulated Pulse Output		
	Hysteresis	Adjustable		
	Response Time	800 ms (50, 80, 120, 200, 400, 1500 ms selectable)		
	Output Short Circuit Protection	Yes		
Accumulated Pulse Output		5 L/Pulse	10 L/Pulse	10 L/Pulse
		20 ft ³ /Pulse	40 ft ³ /Pulse	40 ft ³ /Pulse
Analog Output	Voltage Output	Voltage Output Range : 1 ~ 5 V Output Impedance : 1 kΩ		
	Current Output	Current Output Range : 4 ~ 20mA Load Impedance : ≤ 300 Ω		
External Input		Non-voltage input , ≤ 0.4 V , ≥ 30 ms		
Communication Interface		RS485 *4		
Power	Power Supply Voltage	12 ~ 24V DC ± 10 % , Ripple (P-P) ≤ 10 % (UL Class 2)		
	Current Consumption	≤ 50 mA		
Environment	Working Pressure Range	0 ~ 1.0 MPa		
	Withstand Pressure	1.5 MPa		
	Enclosure	IP40		
	Working Fluid Temp.	0 ~ 50°C (No condensation or freezing)		
	Ambient Temp. Range	Operation : 0 ~ 50°C ; Storage : -10 ~ 60°C (No condensation or freezing)		
	Ambient Humidity Range	Operation / Storage : 35 ~ 85 % R.H. (No condensation)		
	Withstand Voltage	250V AC in 1-min (between case and lead wire)		
	Insulation Resistance	≥ 2 MΩ (50V DC , between case and lead wire)		
	Vibration	Total amplitude 1.5 mm or 10 G, 10 Hz - 55 Hz - 10 Hz scan for 1 minute, 2 hours each direction of X, Y and Z		
Shock	100 m/s ² (10 G) , 3 times each in direction of X, Y and Z			
Lead Wire		Ø4 PVC - 26 AWG (0.15 mm ²) - 6 cores		
Weight (with 2 meter lead wire)		Approx. 281.7 g (500 / 1000 L) ; Approx. 344 g (2000 L)		

NOTE :

*1. CONDITION : Inlet Pressure : 600 kPa, Outlet Pressure : 1 atmospheric pressure, 25 °C

*2. CONDITION : Outlet Pressure : 1 atmospheric pressure, 25 °C

*3. 0 ~ 1.0 MPa, Outlet Pressure : 1 atmospheric pressure, 25 °C

*4. This function only available for RS485 (Output Specification -02 and -04).

6 Pressure Loss Characteristics

● KF02A-501 (500 L/min)

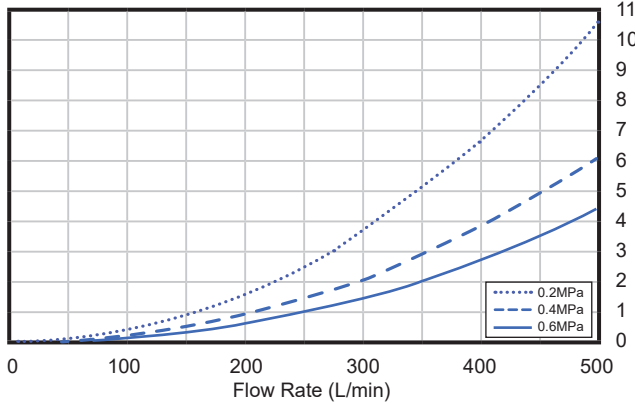

● KF02A-102 (1000 L/min)

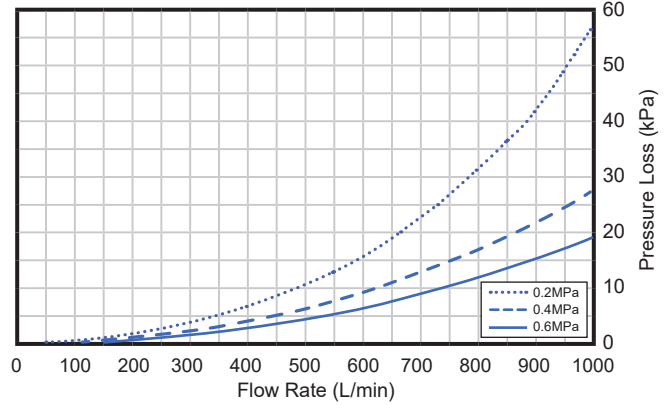

● KF02A-202 (2000 L/min)

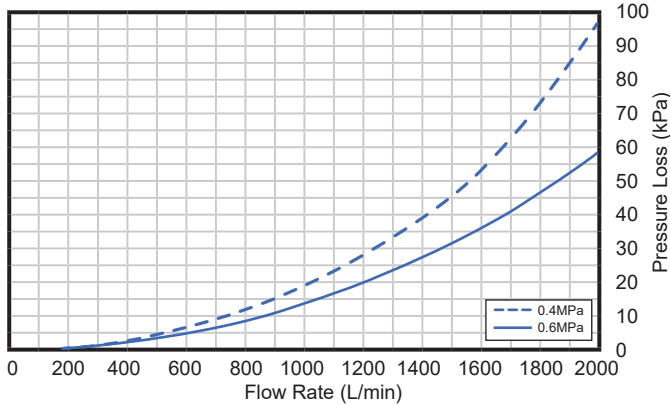

7 Thermal Mass Flow Sensor Principles

Symmetric Temperature Profile No Flow

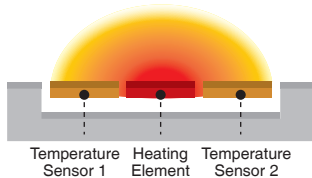

(a) : No Flow

In the absence of flow, the heat from the heater spreads evenly left and right, so the temperature distribution is like (a).

Skewed Temperature Profile Small Flow

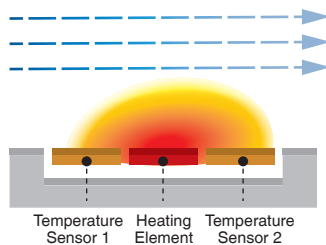

(b) : Small Flow

When flow begins, the inlet side is cooled by the flow, the outlet side is warmed by the heat of the inlet side of the heater, and the temperature distribution is like (b).

Skewed Temperature Profile Large Flow

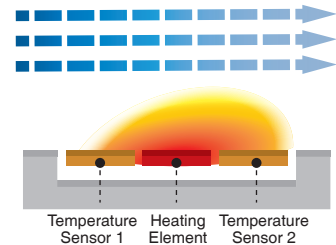

(c) : Large Flow

When the flow increases, it becomes a distribution like (C). Since the temperature distribution before and after the heater is proportional to the flow rate, the flow rate can be determined from the ratio.

8 Ordering Information

K F 0 2 A - 5 0 1 - 0 1 0 - F 7 C

Flow Rate Range

501 : 500 L/min
102 : 1000 L/min
202 : 2000 L/min

Output Specifications

010 : 2 NPN output + Analog output 1~5V
011 : 2 NPN output + Analog output 4~20mA
02 : 2 NPN output + RS485
030 : 2 PNP output + Analog output 1~5V
031 : 2 PNP output + Analog output 4~20mA
04 : 2 PNP output + RS485

Port Size

F7C : Rc1/2", for Flow Rate Range 501, 102.
F9C : G1/2", for Flow Rate Range 501, 102.
F10C : Rc3/4", for Flow Rate Range 202.
F12C : G3/4", for Flow Rate Range 202.

Optional Parts

BT-27 : Mounting bracket, for Flow Rate Range 501, 102.
BT-28 : Mounting bracket, for Flow Rate Range 202.

9 Dimensions

1. Product

- Flow Rate Range 501, 102
(Port Size : Rc1/2", G1/2")

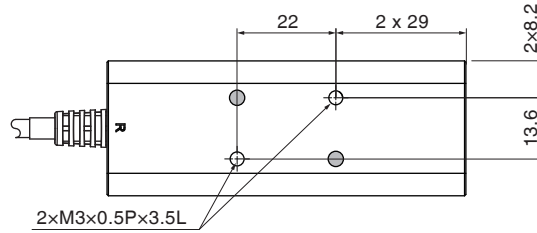
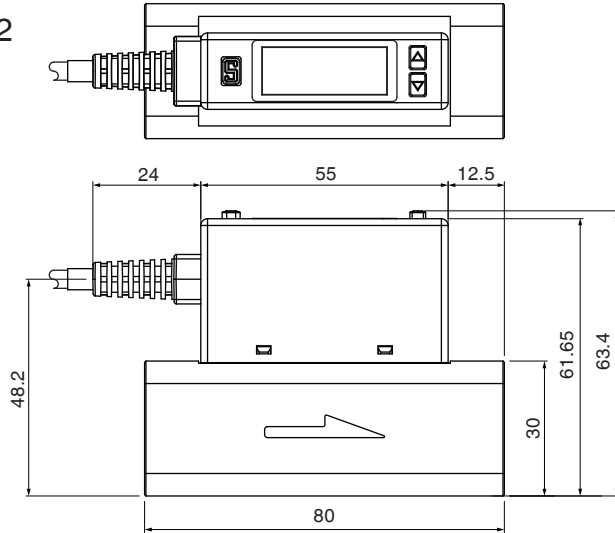
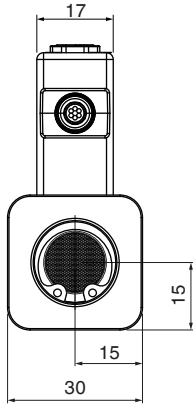

2xM3x0.5Px3.5L

※ Please do not use grey holes which are invalid.

- Flow Rate Range 202
(Port Size : Rc3/4", G3/4")

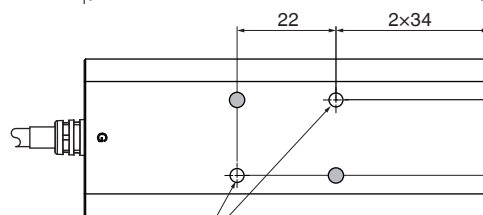
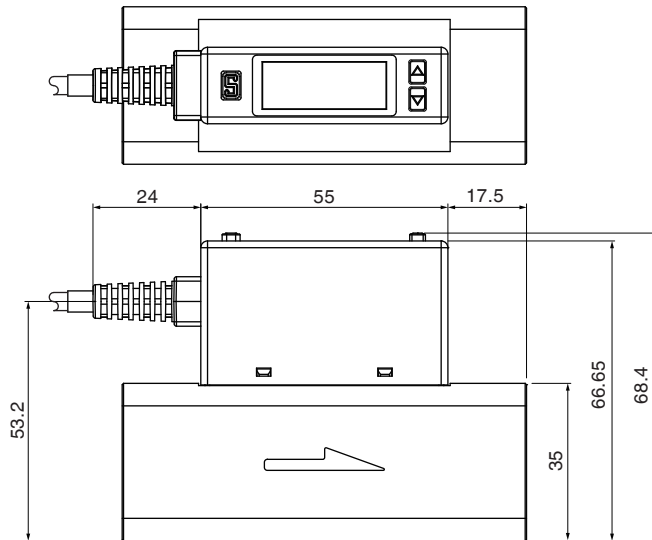
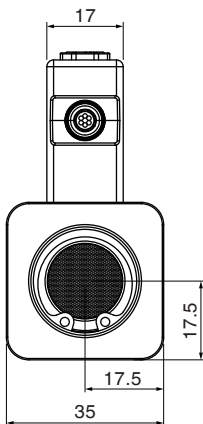

2xM3x0.5Px3.5L

※ Please do not use grey holes which are invalid.

Unit : mm

2. Mounting Bracket

● Flow Rate Range : 501, 102

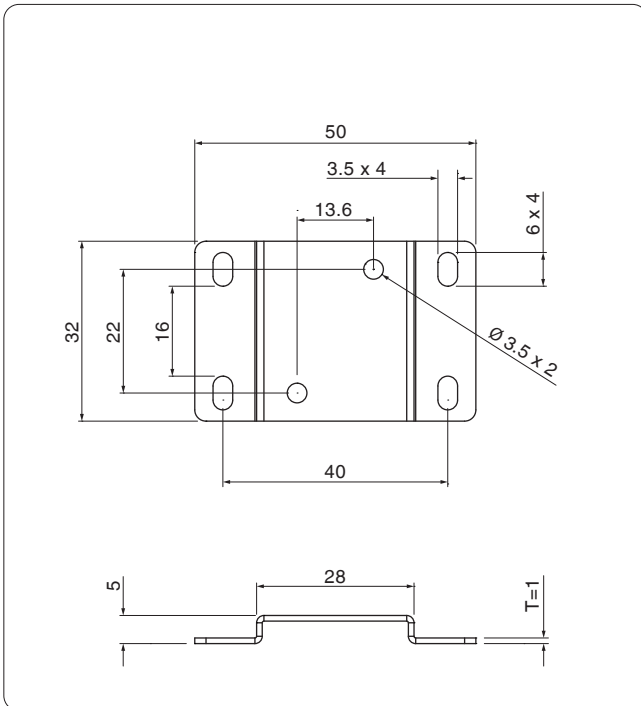

● Flow Rate Range : 202

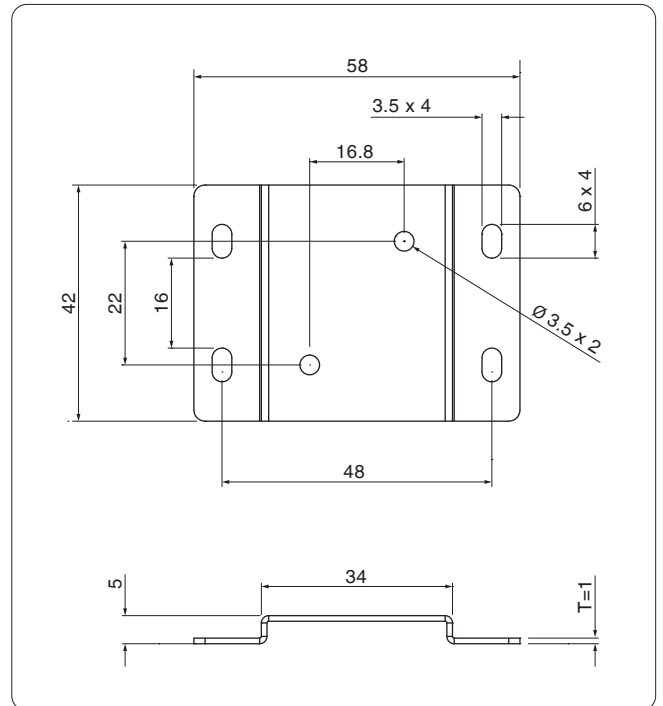

Unit : mm

10 Construction

Appearance

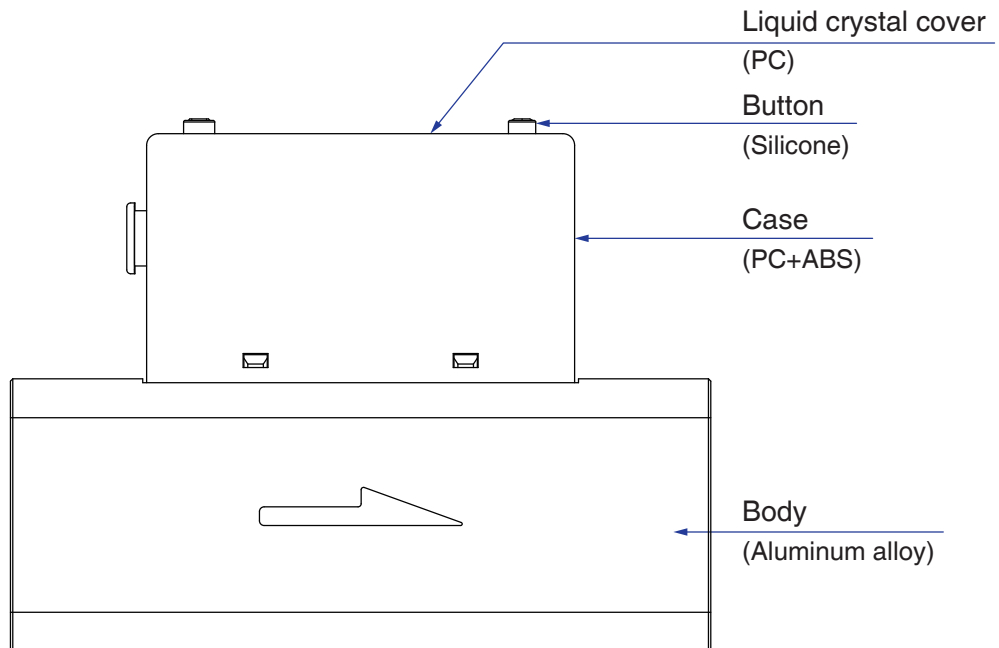

Wetted Parts

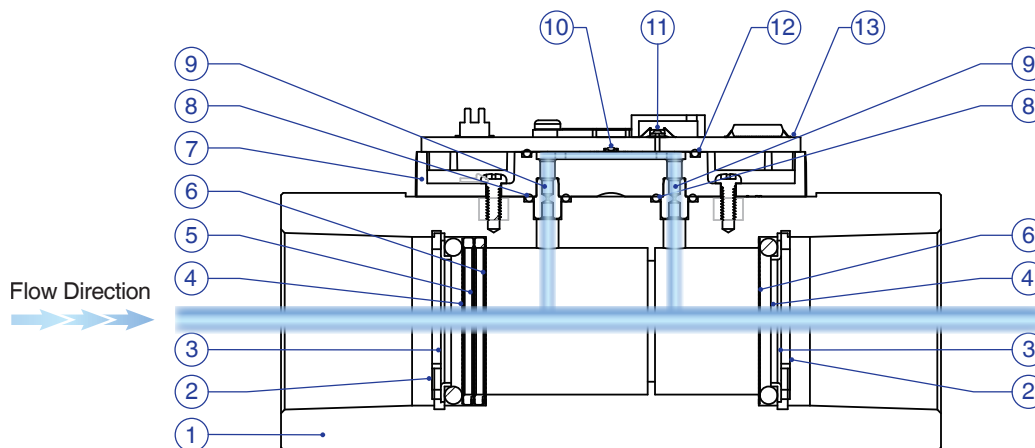

Component Parts

NO.	Description	Material
1	Body	Aluminum alloy
2	C retaining ring	SUS 420
3	L spacer	SUS 304
4	O-ring	Viton
5	Gasket	PPS
6	Port Filter	SUS 304
7	Module Holder	PBT

NO.	Description	Material
8	O-ring	Viton
9	Throttle	SUS 303
10	Sensor	Si
11	Sensor	Si
12	Gasket	Viton
13	Sensor Board	GE4F

