

## ● Precautions for Use

- ① **Operate within the specified voltage.**  
Malfunction or damaged product, electric shock or fire may be resulted by exceeding the specified voltage range.
- ② **Please follow the rated range of flow and pressure to avoid damage.**
- ③ **Do not use flammable fluids and/or permeable fluids.**  
They may cause fire, explosion or corrosion.
- ④ **Do not use in an explosive gas atmosphere.**  
The sensor does not have explosion-proof structure, fire, explosion or corrosion can result.
- ⑤ **Do not use near a surge voltage generated area.**  
If product is nearby the device of surge voltage (e.g., lightning strikes, solenoid lifters, high frequency induction furnaces, motors, etc.), please take measures against the surge sources to prevent damage.
- ⑥ **Do not use in an environment where sensors could be splashed by water or oil.**  
With IP40 compliance, please protect the sensor against dust and water splash.
- ⑦ **Do not use in an environment subject to large temperature cycling.**  
Internal components of the sensor will be damaged by large heating/cooling cycles other than ordinary changes in temperature.
- ⑧ **Do not mount the product in locations where it is exposed to radiant heat.**

## ● Installation Precautions

- ① **This product can be installed in any direction; top, bottom, left, or right.**
- ② **KFPSA-□-01 can be installed with 2 through holes (Ø2).**

Port thread	Tightening torque N·m
M2	0.2 ~ 0.3 N·m

- ③ **When mounting, please use wrench on specified position as below.**  
Using on other parts of the product with a wrench may damage the product.
- ④ **Please ensure the size of fittings are within the width of KFPSA-□-01-M5 while connecting multiple sensors side by side.**
- ⑤ **Please be aware the tightening torque when mounting.**
- ⑥ **After installing, please take a leakage test to ensure the installation is appropriate.**

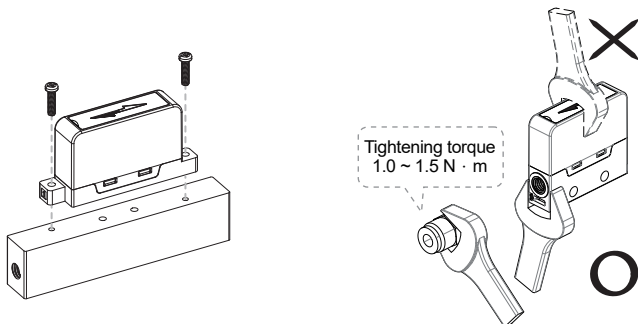

## ● Fluid

- ① **Check the regulator and flow adjustment valve before introducing the fluid.**
- ② **On the inlet side, be sure to install an air filter below the filtration level of 10um.**  
The sensing element cannot measure properly if foreign matter adheres to it.

## ● Use and Maintenance

- ① **Ensure the flow direction of the fluid.**  
Install the pipe by following the arrow indication that shows the air flow direction on the product.
- ② **Flush out all dirt and dust by air blow before connecting the piping to the sensor.**
- ③ **Do not drop or hit.**  
When installation, do not drop, hit or apply excessive shock (100m/s<sup>2</sup>), permanent damage to the internal component of the sensor may occur.
- ④ **Please avoid repeatedly bending, carrying heavy objects, or stretching the lead wire.**  
Securing the wire near the sensor can prevent repeated bending stress, tensile stress, movement, or vibration of the wire, avoiding wire damage or poor contact with the connector.
- ⑤ **Minimizing the wiring length can help avoid noise interference.**
- ⑥ **Check wire color and terminal number when wiring.**  
Incorrect wiring can cause permanent damages to the sensor, check wire color and terminal number according to the manual before wiring.
- ⑦ **Confirm wiring insulation**  
Please avoid poor insulations (and interference from another circuit, poor insulation between terminals, etc.) it can lead to over current being applied to the product, causing damage.
- ⑧ **Please use a separate route for the sensor product wiring and keep separate from any other power or high voltage wiring to avoid noise interruption.**
- ⑨ **Do not connect wire when the power is on.**
- ⑩ **Analog output signal will chatter 2 to 3% within 5 minutes when supplying power.**
- ⑪ **Please follow the specified tightening torque.**
- ⑫ **Ensure the safety of products, please confirm ESD device before use.**
- ⑬ **Do not disassemble or modify the product.**
- ⑭ **The accuracy could change by 2 to 3% when the mesh and mesh holding screw of KFPS-□-01-M5 is removed or replaced.**
- ⑮ **Do not touch terminals or connectors when power is on.**
- ⑯ **Sensors at end-of-life must be disposed of in accordance with E-Waste regulations of the country/region, NOT disposed of with regular garbage.**

## ● Nozzle Size Reference

Flow Rate Range (L/min)	Nozzle Size (mm)	Application
-0.3 ~ 0.3	≤ Ø 0.1	Quartz Oscillator, Solder Ball, Micro LEDs
-0.5 ~ 0.5	Ø 0.2	Chip Resistor, Chip Capacitor, Optical Parts, Mini LEDs
-1.0 ~ 1.0	Ø 0.3	
-5.0 ~ 5.0	Inverted Pyramid Die Collets	Silicone wafer (Bear Die Chip Bonder), General Parts
-10 ~ 10	Inverted Pyramid Die Collets	

## A SPECIFICATIONS

MODEL		003	005	010	050	100	R003	R005	R010	R050	R100	
Flow	Measured flow rate range	0 ~ 0.3 L/min	0 ~ 0.5 L/min	0 ~ 1 L/min	0 ~ 5 L/min	0 ~ 10 L/min	-0.3 ~ 0.3 L/min	-0.5 ~ 0.5 L/min	-1 ~ 1 L/min	-5 ~ 5 L/min	-10 ~ 10 L/min	
	Flow Direction	Unidirection					Bidirectional					
Pressure	Rated Pressure Range	-100 ~ 100 kPa										
Withstand Pressure		300 kPa										
Fluid		Dry air, N <sub>2</sub> , Non-corrosive / Non-flammable gas										
Power Supply Voltage		15 ~ 24V DC ±10% , Ripple (P-P) ≤ 10% (Supplied by certified Double Insulated LE or L.P.S. or Class 2 power source.)										
Current Consumption		≤ 30mA										
Flow	Repeatability	≤ ± 2% F.S.										
	Linearity	Non-linearity ※1										
	Temp. Characteristic ※2	≤ ± 0.6% F.S./°C					≤ ± 0.3% F.S./°C					
	Pressure Characteristic ※3	± 10% F.S.					± 5% F.S.					
Pressure	Repeatability	≤ ± 1% F.S.										
	Linearity	± 0.5% F.S.										
	Temp. Characteristic ※2	± 2% F.S.										
Response Time	Flow	≤ 5ms (90% Response time)										
	Pressure	≤ 1ms										
Indicator		Green LED · Orange LED · Red LED										
Analog Output	Flow	Voltage Output Range : 1~5V ±5% F.S. (±0.2V) (Non-linearity) Output Impedance : 1 KΩ										
	Pressure	Voltage Output Range : 1~5V ±1% F.S. (±0.04V) (Linearity) Output Impedance : 1 KΩ										
Environment	Enclosure	IP40										
	Working Fluid Temp.	0 ~ 50°C (No condensation or freezing)										
	Ambient Temp. Range	Operation : 0 ~ 50°C ; Storage : -10 ~ 60°C (No condensation or freezing)										
	Ambient Humidity Range	Operation / Storage : 35 ~ 85% R.H. (No condensation)										
	Withstand Voltage	1000V AC in 1-min (between case and lead wire)										
	Insulation Resistance	≥ 50MΩ (500V DC , between case and lead wire)										
	Vibration	Total amplitude 1.5mm or 10G · 10 Hz - 55 Hz - 10 Hz scan for 1 minute · 2 hours each direction of X, Y and Z										
	Shock	100m/s <sup>2</sup> (10G) · 3 times each in direction of X, Y and Z										
Lead Wire		Ø2.9 PUR - 28 AWG ( 0.078 mm <sup>2</sup> ) - 4 cores ( Use copper wire, 28 AWG ( 0.078 mm <sup>2</sup> ), lead wire plastic part 80°C )										
Weight	Product	Approx. 8.6 g (w/o Port) ; Approx. 12.2 g (M5 Port)										
	Lead Wire ( 3M )	+ 34.5 g										

### 【NOTE】

※1 : Approximate linearity analog output (±10% F.S.) except 0 ~ 10 L and 10 ~ 10 L.

※2 : Benchmark : 25°C (Temperature range : 0 ~ 50°C)

※3 : Benchmark : 150 kPa (Pressure range : -100 ~ 200kPa)

## B ORDERING INFORMATION

### KFPSA - 003 - 01 - M5

#### Flow Rate Range

003 : 0 ~ 0.3 L/min	R003 : -0.3 ~ 0.3 L/min
005 : 0 ~ 0.5 L/min	R005 : -0.5 ~ 0.5 L/min
010 : 0 ~ 1 L/min	R010 : -1 ~ 1 L/min
050 : 0 ~ 5 L/min	R050 : -5 ~ 5 L/min
100 : 0 ~ 10 L/min	R100 : -10 ~ 10 L/min

#### Port Size

Blank : None  
M5 : M5 female thread

#### Output Specifications

01 : 2 Analog output (1 ~ 5V)

#### Optional Parts

BT-29-1 : fit with 1 sensor ( brackets + M3x0.5Px15L screws )  
 BT-29-2 : fit with 2 sensors ( brackets + M3x0.5Px25L screws )  
 BT-29-3 : fit with 3 sensors ( brackets + M3x0.5Px35L screws )  
 BT-29-4 : fit with 4 sensors ( brackets + M3x0.5Px45L screws )  
 BT-29-5 : fit with 5 sensors ( brackets + M3x0.5Px55L screws )

## C OUTPUT CIRCUIT WIRING DIAGRAMS

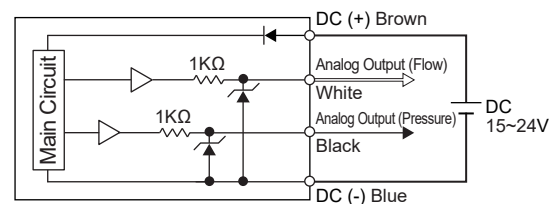

## D PARTS DESCRIPTION

### ● KFPSA-□-01

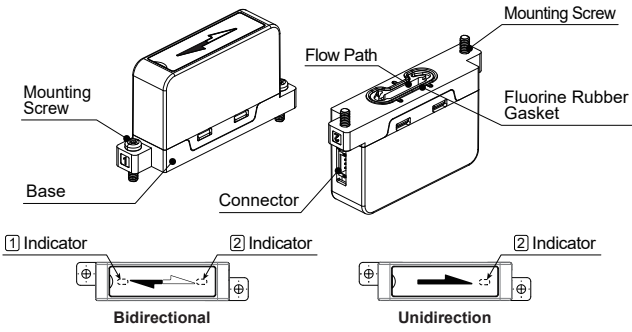

### ● KFPSA-□-01-M5

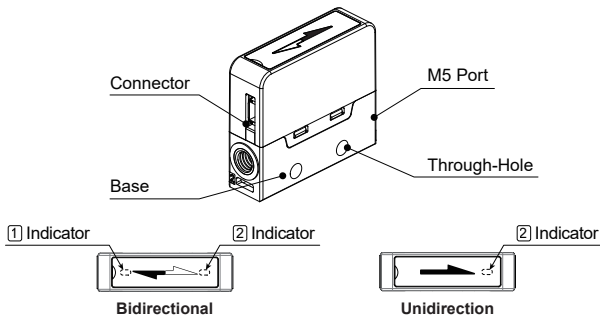

## E DIMENSIONS

### ● KFPSA-□-01

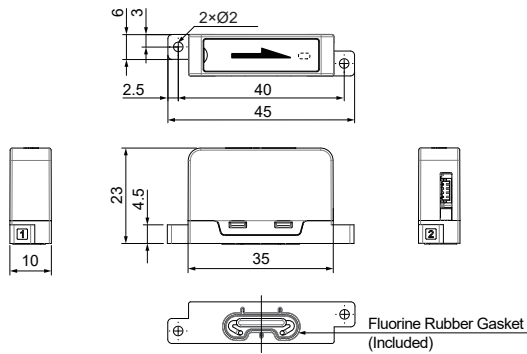

### ● KFPSA-□-01-M5

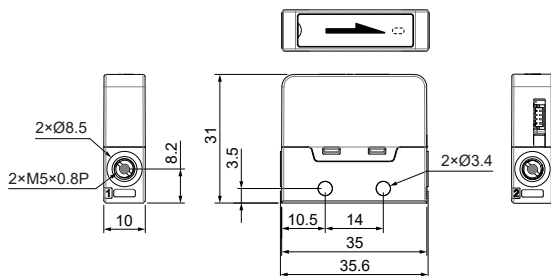

## F OPTIONAL PARTS DIMENSIONS

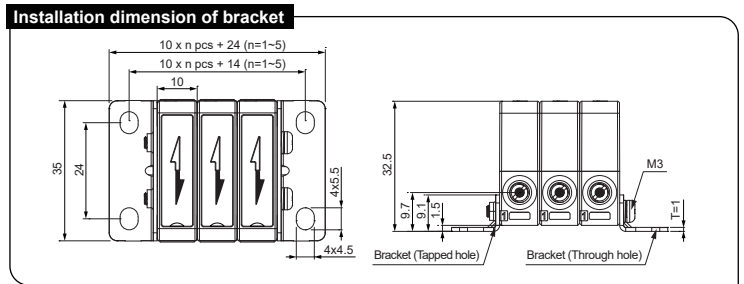
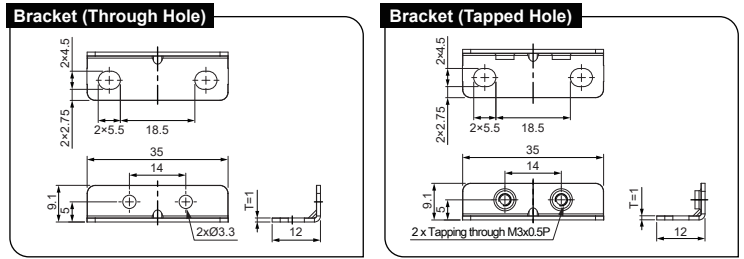

## G INSTALLATION DIMENSION OF KFPS-□-01

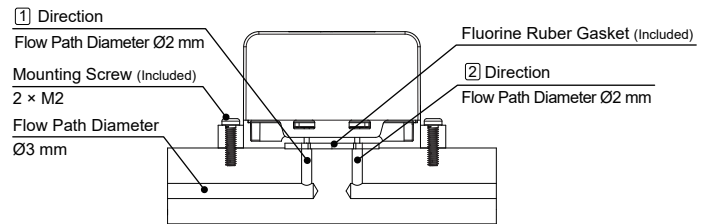

### Dimension for KFPSA-□-01 Base (Top View)

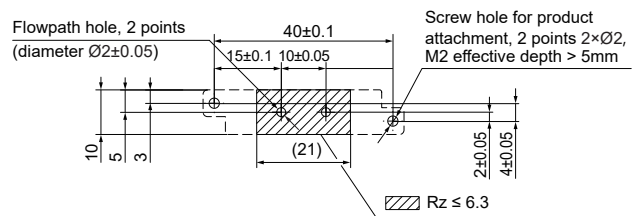

## H MOUNTING BRACKET

### 1. Horizontal mounting

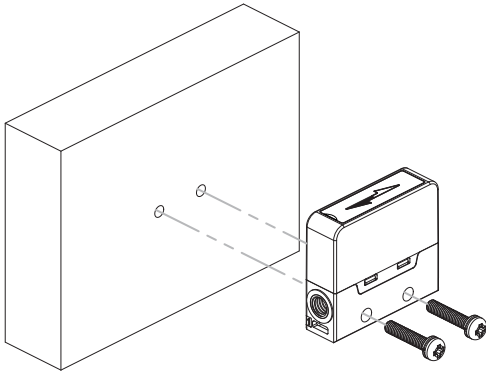

### 2. Bracket mounting

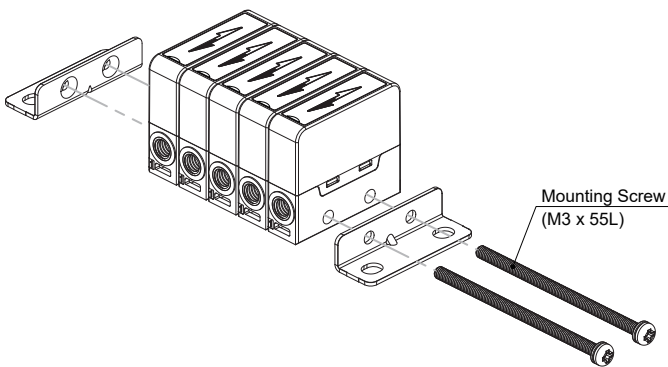
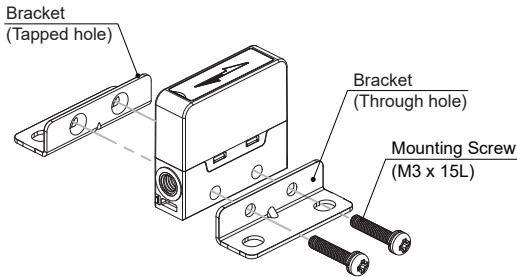
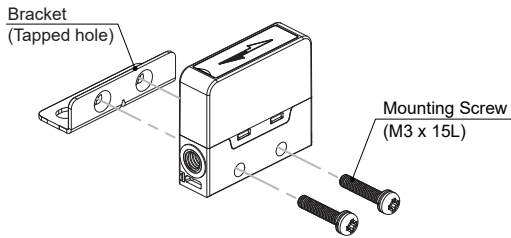

Port thread	Tightening torque N·m
M3	0.2 ~ 0.3 N·m

## I WETTED PARTS

### • KFPSA-□-01

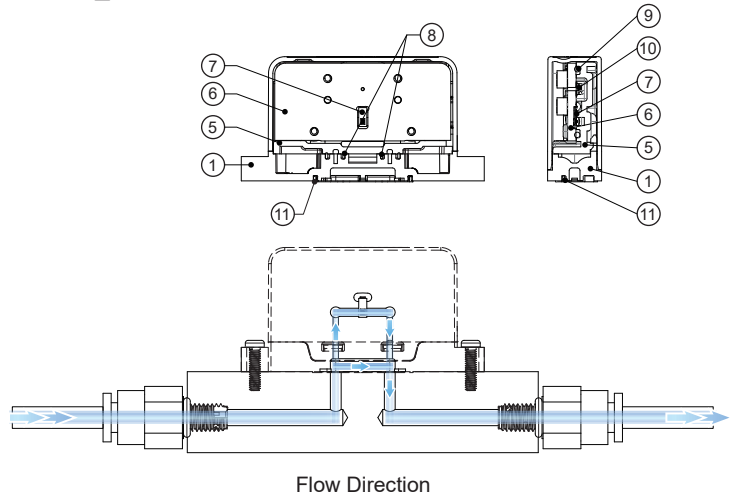

### • KFPSA-□-01-M5

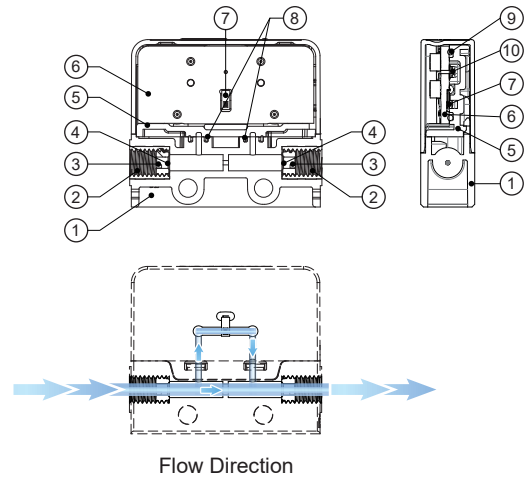

### Component Parts

NO.	Description	Material
1	Base	PBT
2	Fitting for piping	SUS 303
3	Mesh holding screw	POM
4	Mesh	SUS 304
5	PCB-Holder	PBT
6	Sensor Board	GE4F
7	Sensor	Si
8	Gasket	Viton
9	Gasket	Viton
10	Sensor	Si
11	Gasket	Viton

## J OUTPUT CHARACTERISTICS (PRESSURE)

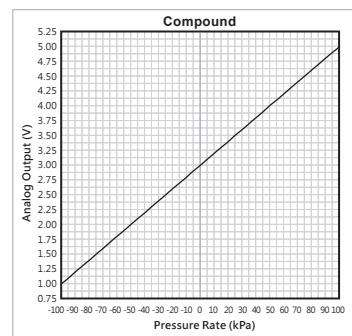

## K OUTPUT CHARACTERISTICS (FLOW)

● KFPSA-003 (0 ~ 0.3 L/min)

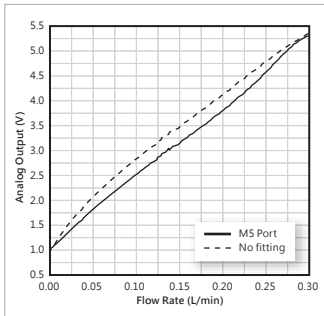

● KFPSA-R003 (-0.3 ~ 0.3 L/min)

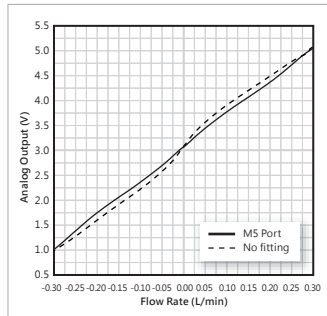

● KFPSA-005 (0 ~ 0.5 L/min)

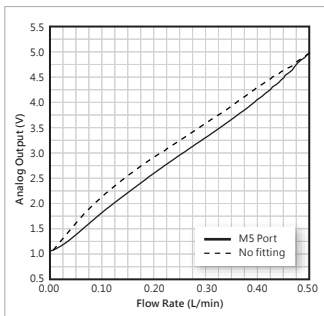

● KFPSA-R005 (-0.5 ~ 0.5 L/min)

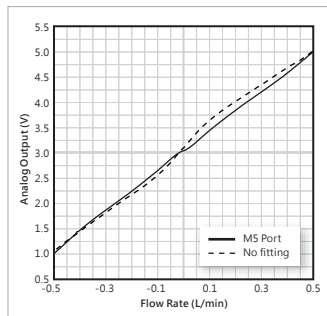

● KFPSA-010 (0 ~ 1 L/min)

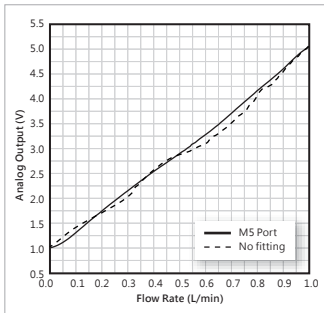

● KFPSA-R010 (-1 ~ 1 L/min)

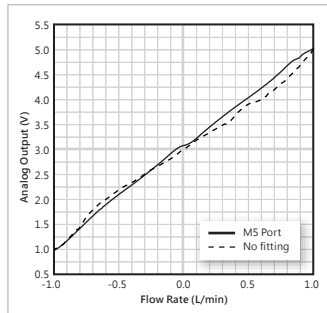

● KFPSA-050 (0 ~ 5 L/min)

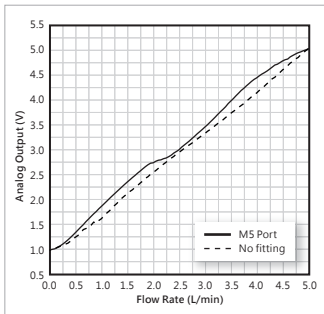

● KFPSA-R050 (-5 ~ 5 L/min)

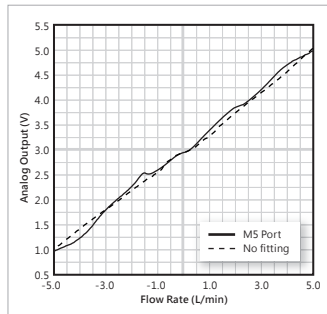

● KFPSA-100 (0 ~ 10 L/min)

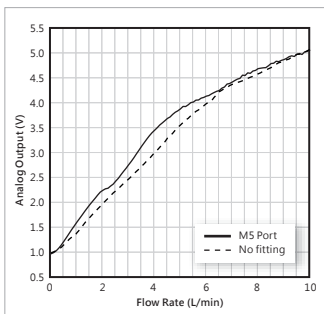

● KFPSA-R100 (-10 ~ 10 L/min)

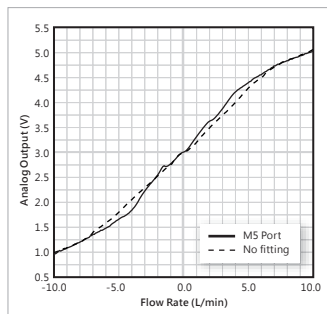

## L RECOMMENDED INSTALLATION OF COMPRESSED AIR LINE

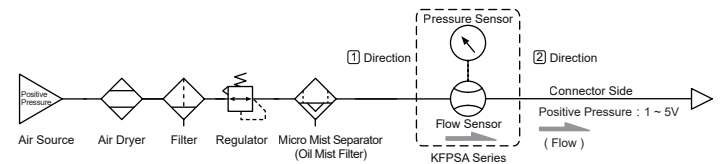

Example :

### Check Adsorption (Bidirectional)

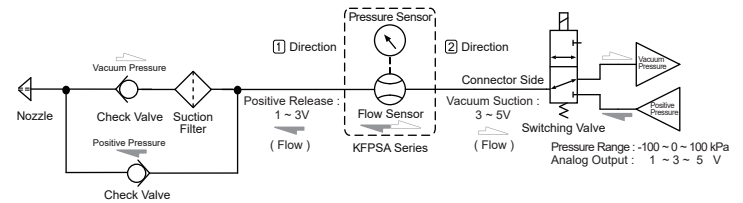

### Positive Pressure Leak Detection (Unidirection)

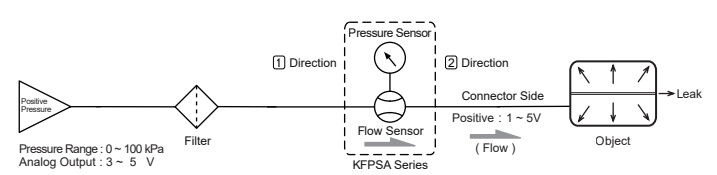

### Vacuum Leak Detection (Unidirection)

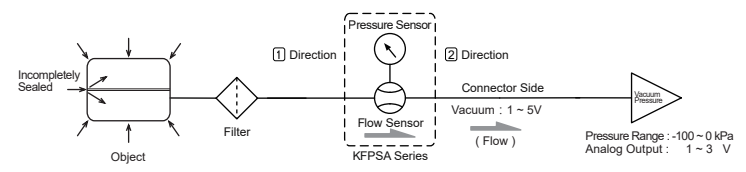

## M LED INDICATOR DESCRIPTION

The real-time status of the fluid such as flow rate, flow direction, positive pressure or vacuum pressure is displayed by the "3-color LED indicator".

According to L. RECOMMENDED INSTALLATION OF COMPRESSED AIR LINE, the description of LED indicator is as follows. (※ Depending on the piping, LED indicator may be displayed differently.)

### ● Unidirectional

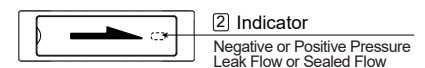

Flow Range (L/min)	Indicator Color	② Indicator		
		Flow (L/min)	Vacuum Pressure (kPa)	Positive Pressure (kPa)
0 ~ 0.3	Green	0.03 ↓	-50 ↑	50 ↑
	Orange	0.03 ↑	-50 ↓	50 ↓
	Red	0.03 ↓	-50 ↓	50 ↓
0 ~ 0.5	Green	0.05 ↓	-50 ↑	50 ↑
	Orange	0.05 ↑	-50 ↓	50 ↓
	Red	0.05 ↓	-50 ↓	50 ↓
0 ~ 1.0	Green	0.1 ↓	-50 ↑	50 ↑
	Orange	0.1 ↑	-50 ↓	50 ↓
	Red	0.1 ↓	-50 ↓	50 ↓
0 ~ 5.0	Green	0.5 ↓	-50 ↑	50 ↑
	Orange	0.5 ↑	-50 ↓	50 ↓
	Red	0.5 ↑	-50 ↓	50 ↓
0 ~ 10	Green	1.0 ↓	-50 ↑	50 ↑
	Orange	1.0 ↑	-50 ↓	50 ↓
	Red	1.0 ↑	-50 ↓	50 ↓

## M LED INDICATOR DESCRIPTION

### • Bidirectional

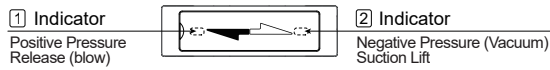

Flow Range (L/min)	Indicator Color	① Indicator Positive Pressure		② Indicator Vacuum Pressure	
		Flow (L/min)	Pressure (kPa)	Flow (L/min)	Pressure (kPa)
-0.3 ~ 0.3	Green	0.08 ↑	100 ↓	0.08 ↓	-50 ↑
	Orange	0.08 ↑	100 ↑	0.08 ↑	-50 ↑
	Red	0.08 ↓	100 ↑	0.08 ↑	-50 ↓
-0.5 ~ 0.5	Green	0.13 ↑	100 ↓	0.13 ↓	-50 ↑
	Orange	0.13 ↑	100 ↑	0.13 ↑	-50 ↑
	Red	0.13 ↓	100 ↑	0.13 ↑	-50 ↓
-1.0 ~ 1.0	Green	0.25 ↑	100 ↓	0.25 ↓	-50 ↑
	Orange	0.25 ↑	100 ↑	0.25 ↑	-50 ↑
	Red	0.25 ↓	100 ↑	0.25 ↑	-50 ↓
-5.0 ~ 5.0	Green	1.25 ↑	100 ↓	1.25 ↓	-50 ↑
	Orange	1.25 ↑	100 ↑	1.25 ↑	-50 ↑
	Red	1.25 ↓	100 ↑	1.25 ↑	-50 ↓
-10 ~ 10	Green	2.5 ↑	100 ↓	2.5 ↓	-50 ↑
	Orange	2.5 ↑	100 ↑	2.5 ↑	-50 ↑
	Red	2.5 ↓	100 ↑	2.5 ↑	-50 ↓