

## ● Precautions for Use

- ① **Operate within the specified voltage.**  
Malfunction or damaged product, electric shock or fire may be resulted by exceeding the specified voltage range.
- ② **Please follow the rated range of flow to avoid damage.**
- ③ **Do not use flammable fluids and/or permeable fluids.**  
They may cause fire, explosion or corrosion.
- ④ **Do not use in an explosive gas atmosphere.**  
The sensor does not have explosion-proof structure, fire, explosion or corrosion can result.
- ⑤ **Do not use near a surge voltage generated area.**  
If product is nearby the device of surge voltage (e.g., lightning strikes, solenoid lifters, high frequency induction furnaces, motors, etc.), please take measures against the surge sources to prevent damage.
- ⑥ **Do not use in an environment where sensors could be splashed by water or oil.**  
With IP40 compliance, please protect the sensor against dust and water splash.
- ⑦ **Do not use in an environment subject to large temperature cycling.**  
Internal components of the sensor will be damaged by large heating/cooling cycles other than ordinary changes in temperature.
- ⑧ **Do not mount the product in locations where it is exposed to radiant heat.**

## ● Installation Precautions

- ① **This product can be installed in any direction; top, bottom, left, or right.**
- ② **KFSA-□-01 can be installed with 2 through holes (Ø2).**

Port thread	Tightening torque N·m
M2	0.2 ~ 0.3 N·m

- ③ **When mounting, please use wrench on specified position as below.**  
Using on other parts of the product with a wrench may damage the product.
- ④ **Please ensure the size of fittings are within the width of KFSA-□-01-M5 while connecting multiple sensors side by side.**
- ⑤ **Please be aware the tightening torque when mounting.**
- ⑥ **After installing, please take a leakage test to ensure the installation is appropriate.**

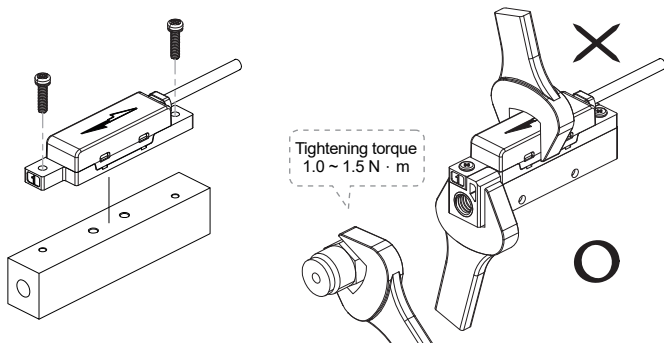

## ● Fluid

- ① **Check the regulator and flow adjustment valve before introducing the fluid.**
- ② **On the inlet side, be sure to install an air filter below the filtration level of 10µm.**  
The sensing element cannot measure properly if foreign matter adheres to it.

## ● Use and Maintenance

- ① **Ensure the flow direction of the fluid.**  
Install the pipe by following the arrow indication that shows the air flow direction on the product.
- ② **Flush out all dirt and dust by air blow before connecting the piping to the sensor.**
- ③ **Do not drop or hit.**  
When installation, do not drop, hit or apply excessive shock (100m/s<sup>2</sup>), permanent damage to the internal component of the sensor may occur.
- ④ **Please avoid repeatedly bending, carrying heavy objects, or stretching the lead wire.**  
Securing the wire near the sensor can prevent repeated bending stress, tensile stress, movement, or vibration of the wire, avoiding wire damage or poor contact.
- ⑤ **Minimizing the wiring length can help avoid noise interference.**
- ⑥ **Check wire color and terminal number when wiring.**  
Incorrect wiring can cause permanent damages to the sensor, check wire color and terminal number according to the manual before wiring.
- ⑦ **Confirm wiring insulation**  
Please avoid poor insulations (and interference from another circuit, poor insulation between terminals, etc.) it can lead to over current being applied to the product, causing damage.
- ⑧ **Please use a separate route for the sensor product wiring and keep separate from any other power or high voltage wiring to avoid noise interruption.**
- ⑨ **Do not connect wire when the power is on.**
- ⑩ **Analog output signal will chatter 2 to 3% within 5 minutes when supplying power.**
- ⑪ **Please follow the specified tightening torque.**
- ⑫ **Ensure the safety of products, please confirm ESD device before use.**
- ⑬ **Do not disassemble or modify the product.**
- ⑭ **The accuracy could change by 2 to 3% when the mesh and mesh holding screw of KFSA-□-01-M5 is removed or replaced.**

## ● Nozzle Size Reference

Flow Rate Range (L/min)	Nozzle Size (mm)	Application
-0.3 ~ 0.3	≤ Ø 0.1	Quartz Oscillator, Solder Ball, Micro LEDs
-0.5 ~ 0.5	Ø 0.2	Chip Resistor, Chip Capacitor, Optical Parts, Mini LEDs
-1.0 ~ 1.0	Ø 0.3	
-5.0 ~ 5.0	Inverted Pyramid Die Collets	Silicone wafer (Bear Die Chip Bonder), General Parts
-10 ~ 10	Inverted Pyramid Die Collets	

## A SPECIFICATIONS

MODEL		003	005	010	050	100	R003	R005	R010	R050	R100
Measured Flow Rate Range		0 ~ 0.3 L/min	0 ~ 0.5 L/min	0 ~ 1 L/min	0 ~ 5 L/min	0 ~ 10 L/min	-0.3 ~ 0.3 L/min	-0.5 ~ 0.5 L/min	-1 ~ 1 L/min	-5 ~ 5 L/min	-10 ~ 10 L/min
Flow Direction		Unidirection					Bidirectional				
Withstand Pressure		300 kPa									
Fluid		Dry air, N <sub>2</sub> , Non-corrosive / Non-flammable gas									
Power Supply Voltage		15 ~ 24V DC ±10% , Ripple (P-P) ≤ 10%									
Current Consumption		≤ 20mA									
Accuracy	Repeatability	≤ ± 2% F.S.									
	Linearity	Non-linearity									
	Temp. Characteristic ※1	≤ ± 0.6% F.S./°C					≤ ± 0.3% F.S./°C				
	Pressure Characteristic ※2	± 10% F.S.					± 5% F.S.				
Response Time		≤ 5ms (90% Response time)									
Indicator		Green LED									
Analog Output		Voltage Output Range : 1~5V ±5% F.S. (±0.2V) (Non-linearity) Output Impedance : 1 KΩ									
Environment	Working Pressure Range	-100 ~ 200 kPa									
	Enclosure	IP40									
	Working Fluid Temp.	0 ~ 50°C (No condensation or freezing)									
	Ambient Temp. Range	Operation : 0 ~ 50°C ; Storage : -10 ~ 60°C (No condensation or freezing)									
	Ambient Humidity Range	Operation / Storage : 35 ~ 85% R.H. (No condensation)									
	Withstand Voltage	1000V AC in 1-min (between case and lead wire)									
	Insulation Resistance	≥ 50MΩ (500V DC , between case and lead wire)									
	Vibration	Total amplitude 1.5mm or 10G · 10 Hz - 55 Hz - 10 Hz scan for 1 minute · 2 hours each direction of X, Y and Z									
Shock		100m/s <sup>2</sup> (10G) · 3 times each in direction of X, Y and Z									
Lead Wire		Ø2.6 Oil-resistance cable ( PVC ) - 26 AWG ( 0.15 mm <sup>2</sup> ) - 3 cores									
Weight	Product	Approx. 4 g (w/o Port) ; Approx. 9.6 g (M5 Port)									
	Lead Wire ( 3M )	+ 31.8 g									

### 【NOTE】

※1 : Benchmark : 25°C (Temperature range : 0 ~ 50°C)

※2 : Benchmark : 150 kPa (Pressure range : -100 ~ 200kPa)

## B ORDERING INFORMATION

**K F S A - 0 0 3 - 0 1 - M 5**

### Flow Rate Range

003 : 0 ~ 0.3 L/min    R003 : -0.3 ~ 0.3 L/min  
 005 : 0 ~ 0.5 L/min    R005 : -0.5 ~ 0.5 L/min  
 010 : 0 ~ 1 L/min        R010 : -1 ~ 1 L/min  
 050 : 0 ~ 5 L/min        R050 : -5 ~ 5 L/min  
 100 : 0 ~ 10 L/min       R100 : -10 ~ 10 L/min

### Port Size

Blank : None  
 M5 : M5 female thread

### Output Specifications

01 : 1 Analog output (1 ~ 5V)

### Optional Parts

BT-30-1 : fit with 1 sensor ( brackets + M2x0.4Px15L screws )  
 BT-30-2 : fit with 2 sensors ( brackets + M2x0.4Px25L screws )  
 BT-30-3 : fit with 3 sensors ( brackets + M2x0.4Px35L screws )  
 BT-30-4 : fit with 4 sensors ( brackets + M2x0.4Px45L screws )  
 BT-30-5 : fit with 5 sensors ( brackets + M2x0.4Px55L screws )

## C OUTPUT CIRCUIT WIRING DIAGRAMS

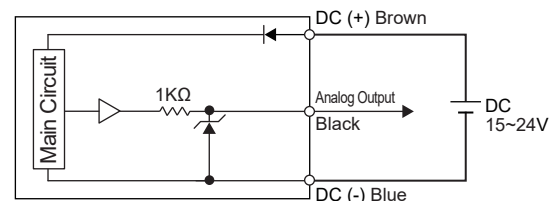

## D PARTS DESCRIPTION

### ● KFSA-□-01

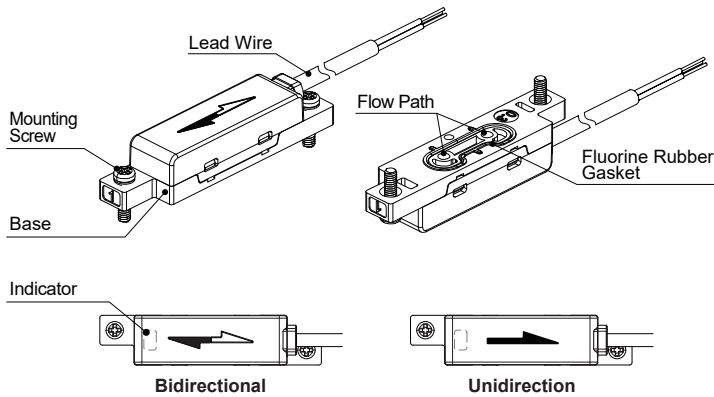

### ● KFSA-□-01-M5

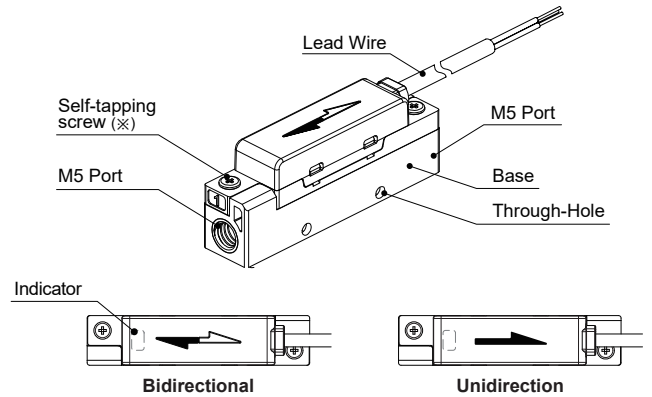

※ Do not set the self-tapping screws repeatedly.

## E DIMENSIONS

### ● KFSA-□-01

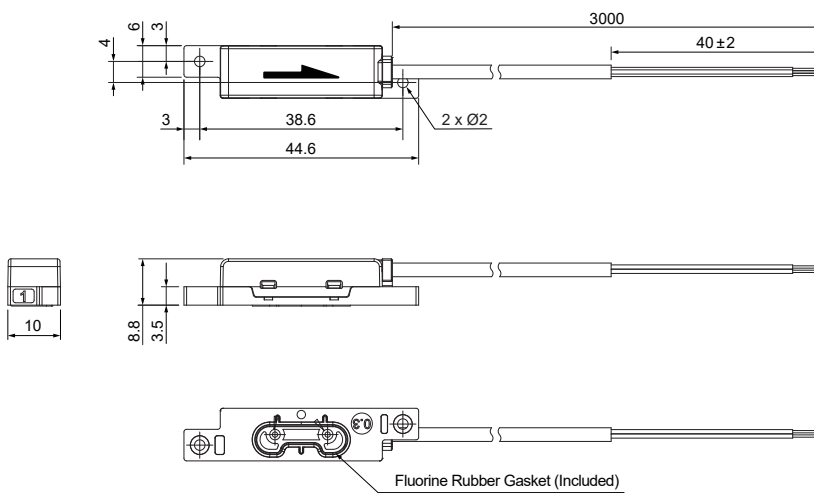

### ● KFSA-□-01-M5

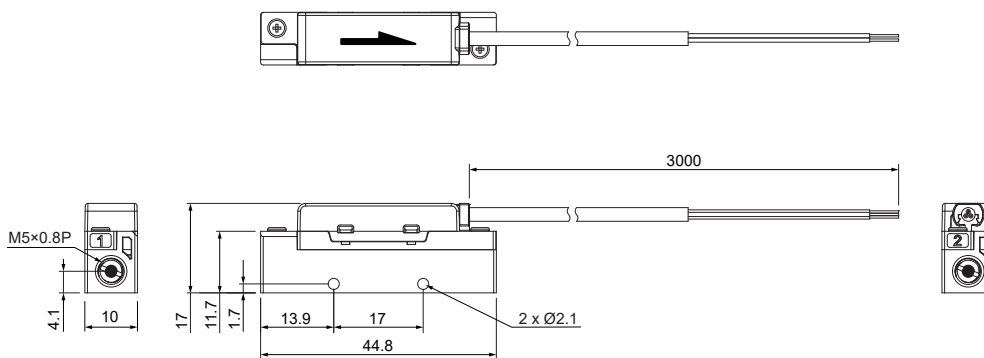

## F OPTIONAL PARTS DIMENSIONS

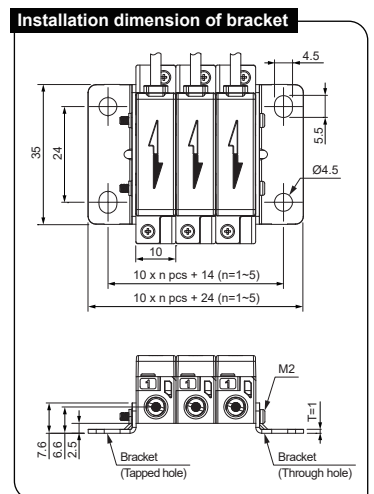
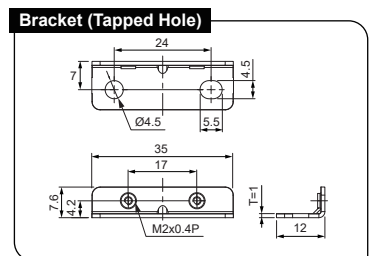
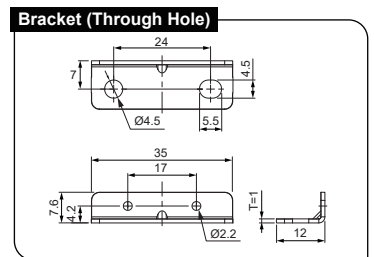

## G INSTALLATION DIMENSION OF KFS-□-01

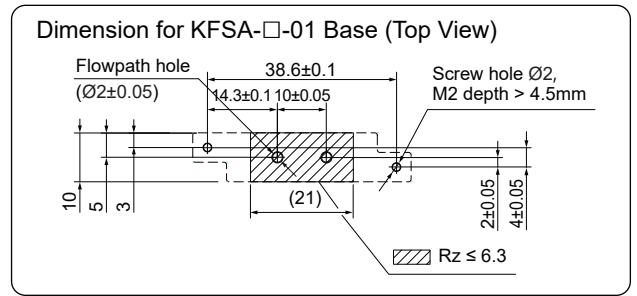
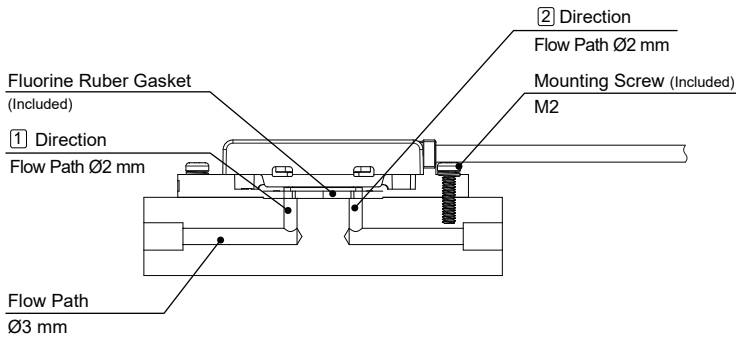

## H MOUNTING BRACKET

### 1. Horizontal mounting

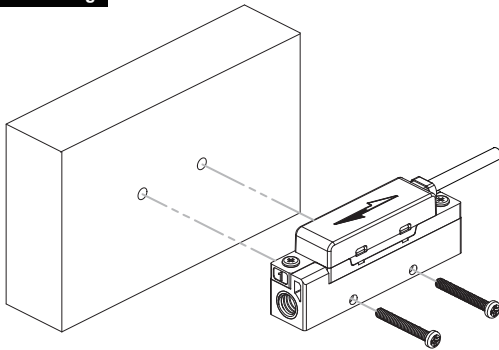

### 2. Bracket mounting

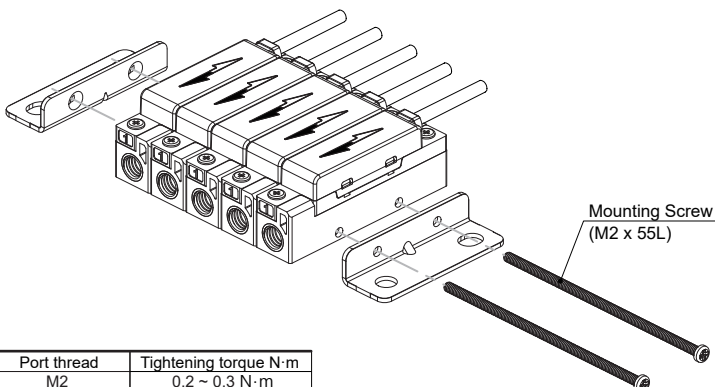
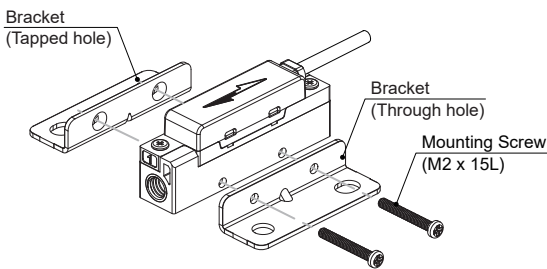
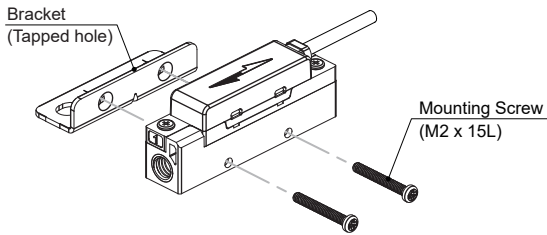

Port thread	Tightening torque N·m
M2	0.2 ~ 0.3 N·m

## I WETTED PARTS

### • KFS-□-01

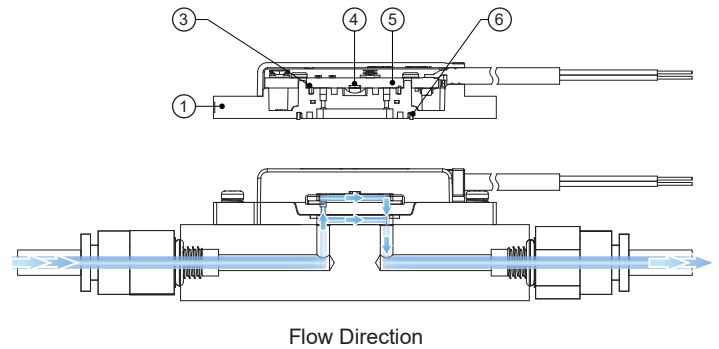

### • KFS-□-01-M5

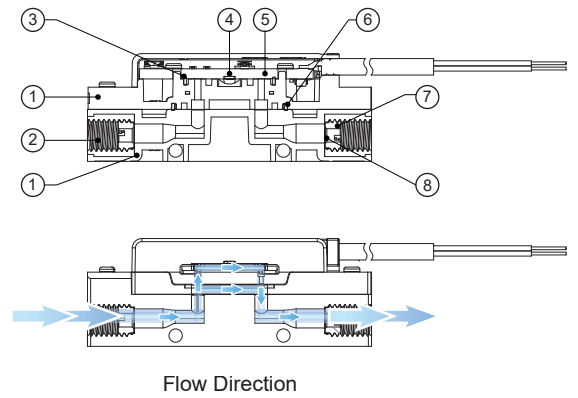

### Component Parts

NO.	Description	Material
1	Base	PBT
2	Fitting for piping	SUS 303
3	Gasket	Viton
4	Sensor	Si
5	Sensor Board	GE4F
6	Gasket	Viton
7	Mesh holding screw	POM
8	Mesh	SUS 304

## J OUTPUT CHARACTERISTICS

● KFSA-003 (0 ~ 0.3 L/min)

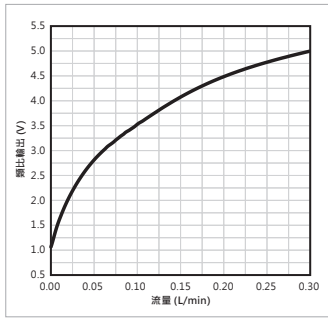

● KFSA-R003 (-0.3 ~ 0.3 L/min)

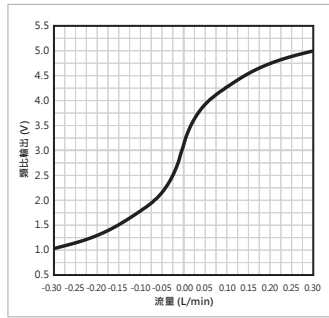

● KFSA-005 (0 ~ 0.5 L/min)

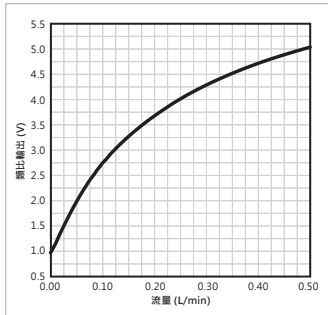

● KFSA-R005 (-0.5 ~ 0.5 L/min)

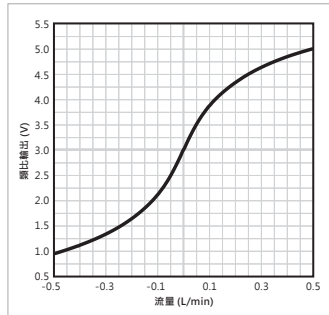

● KFSA-010 (0 ~ 1 L/min)

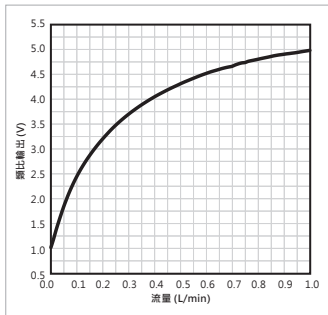

● KFSA-R010 (-1 ~ 1 L/min)

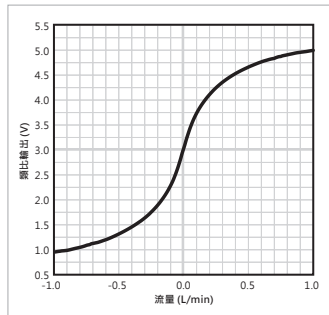

● KFSA-050 (0 ~ 5 L/min)

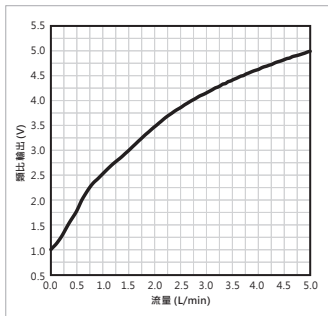

● KFSA-R050 (-5 ~ 5 L/min)

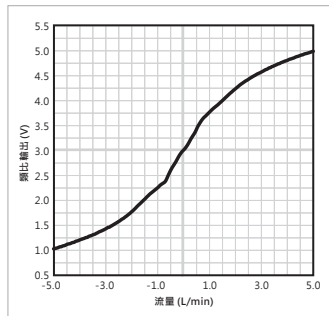

● KFSA-100 (0 ~ 10 L/min)

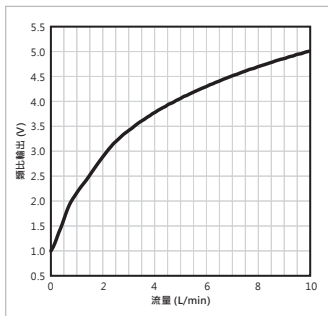

● KFSA-R100 (-10 ~ 10 L/min)

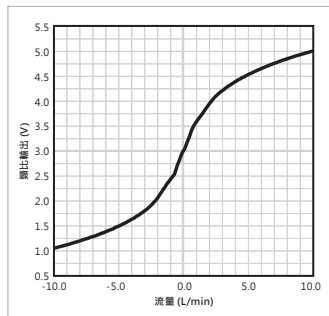

## K RECOMMENDED INSTALLATION OF COMPRESSED AIRLINE

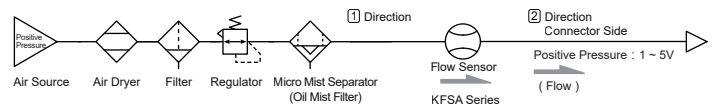

### Example :

#### Check Adsorption (Bidirectional)

※ Response speed of the sensor might be delayed due to the piping volume between the suction nozzle and flow sensor.  
Piping volume: Large=response speed slow ; Small= response speed fast.

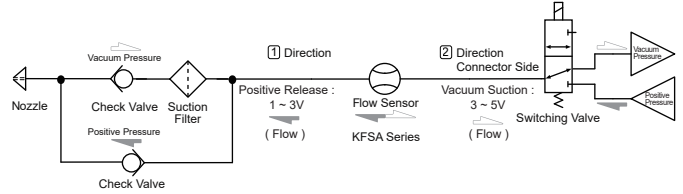

#### Positive Pressure Leak Detection (Unidirection)

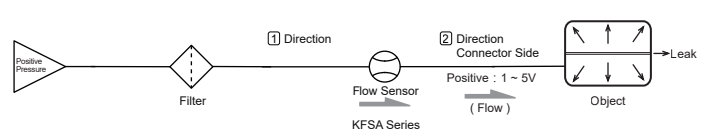

#### Vacuum Leak Detection (Unidirection)

